

CEMP Engineer Design Guide 1110-3-134	Department of the Army U.S. Army Corps of Engineers Washington, DC 20314-1000	DG 1110-3-134 April 1975
	Design Guide COMMISSIONED AND NON- COMMISSIONED OFFICERS CLUBS	
	Distribution Restriction Statement Approved for public release; distribution is unlimited.	

DG 1110-3-134
APRIL 1975

DESIGN GUIDE

**COMMISSIONED AND NON-COMMISSIONED
OFFICERS CLUBS**

DEPARTMENT OF THE ARMY
OFFICE OF THE CHIEF OF ENGINEERS
MILITARY CONSTRUCTION DIRECTORATE
ENGINEERING DIVISION
WASHINGTON, DC 20314

LIMITED DISTRIBUTION

Foreword

The Design Guide (DG) series has been established to replace material previously issued under the standard design medium by the Engineering Division, Military Construction Directorate, Office of the Chief of Engineers, U.S. Army.

This guide governs the design of Army officers and NCO clubs. Army officers and NCO clubs provide for the morale, welfare, and recreational support of their members and authorized guests.

The guide is intended not only to state basic criteria,- but also to provide a means by which the user of the guide can apply the criteria in individual ways to respond to local requirements. This guide is applicable to all new construction projects for Army Clubs and projects involving modernization of existing facilities.

Detailed development of this guide was under the direction of the Special Projects Section, Structures Branch of the Engineering Division. Major parts of the material contained herein are based on the results of an architectural services contract with the firm of Building Systems Development, San Francisco, California, under Contract No. DACA 73-74-C-0003. The functional requirements in this guide have been developed in conjunction with, and approved by, the Club Management Directorate of the U.S. Army Adjutant General Center, (DAAG-CM).

Distribution of this guide is limited. Additional essential copies are available from the OCE Publications Depot, 890 South Pickett Street, Alexandria, Virginia 22304.

Users are invited to send comments and suggested improvements to HQDA (DAEN-MCE-A), Wash DC 20314.

FOR THE CHIEF OF ENGINEERS:



LEE S. GARRETT
Chief, Engineering Division
Directorate of Military Construction

COMMISSIONED AND NON-COMMISSIONED OFFICERS CLUBS

Table of Contents

	<u>Page No.</u>
SECTION 1. INTRODUCTION	
1-1 PURPOSE.	1-2
1-2 PRIMARY REFERENCES.	1-3
1-3 SCOPE.	1-4
1-4 EMPHASIS.	1-5
1-5 RESPONSIBILITIES.	1-6
SECTION 2. GENERAL PLANNING CONSIDERATIONS	
2-1 THE CLUB CONCEPT.	2-2
2-2 PLANNING THE CLUB.	2-6
SECTION 3. INDIVIDUAL SPACE CRITERIA	
3-1 ENTRY.	3-2
3-2 DINING.	3-7
3-3 BAR.	3-15
3-4 KITCHEN.	3-19
3-5 MULTI-USE.	3-39
3-6 PARTY ROOM.	3-45
3-7 QUIET RECREATION.	3-49
3-8 NOISY RECREATION.	3-51
3-9 ADMINISTRATION.	3-53
3-10 REST ROOMS.	3-57
3-11 STORAGE.	3-59
3-12 MAINTENANCE.	3-61
3-13 MECHANICAL.	3-63
3-14 LOCKER ROOM.	3-65
SECTION 4. SUBSYSTEM ALTERNATIVES	
4-1 GENERAL.	4-2
4-2 STRUCTURE.	4-4
4-3 HEATING, VENTILATING AND AIR CONDITIONING.	4-7
4-4 ENVELOPE.	4-13
4-5 INTERIOR PARTITIONS.	4-17
4-6 CEILING.	4-23
4-7 LIGHTING.	4-27

SECTION 5. PLANNING AND DESIGN PROCESS

5-1 THE PLANNING AND DESIGN PROCESS.	5-2
5-2 THE STEPS IN THE PLANNING AND DESIGN PROCESS.	5-2
5-3 SEQUENCE OF STEPS IN PLANNING AND DESIGN PROCESS.	5-2

SECTION 6. GENERAL DESIGN CONSIDERATIONS

6-1 SITE.	6-2
6-2 ARCHITECTURE.	6-7
6-3 INTERIOR.	6-47

SECTION 7. ILLUSTRATIVE CRITERIA APPLICATIONS

7-1 GENERAL.	7-1
7-2 JOINT CLUB.	7-2
7-3 SMALL OFFICERS CLUB.	7-13
7-4 MEDIUM OFFICERS CLUB.	7-21
7-5 LARGE OFFICERS CLUB	7-33
7-6 SMALL NCO CLUB	7-45
7-7 MEDIUM NCO CLUB	7-59
7-8 LARGE NCO CLUB	7-71

List of Tables

2-1 Typical Club Activities	2-3
2-2 Officers Club Users by Age Group	2-4
2-3 NCO Club Users by Age Group	2-4
2-4 List of Spaces	2-8
2-5 Sizing for Generic Spaces: Officers Clubs	2-10
2-6 Sizing for Generic Spaces: NCO Clubs	2-10
4-1 Structural Design Criteria	4-4
4-2 Structural Framing Alternatives	4-6
4-3 H.V.A.C. Cost Performance Summary	4-12
4-4 Envelope: Cost/Performance Summary	4-16
4-5 Partitions: Cost/Performance Summary	4-22
4-6 Ceilings: Cost/Performance Summary	4-26
4-7 Lighting Standards for Generic Spaces	4-28
4-8 Lighting: Cost/Performance Summary	4-32
5-1 Planning and Design Process	5-3
5-2 Explanation of Steps in Planning & Design Process	5-4

List of Figures

	Page No.
3-1 Planning Dimensions for Coat Room	3-3
3-2 Affinity Matrix for Entry	3-5
3-3 Relationship of Entry to Other Spaces (Small Clubs)	3-6
3-4 Relationship of Entry to Other Spaces (Large Clubs)	3-6
3-5 Planning Dimensions of Dining Table Layout	3-8
3-6 Planning Dimensions for Dining Table and Booth Layout	3-8
3-7 Planning Dimensions for Cashier's Station	3-11
3-8 Planning Dimensions for Waitress Station	3-12
3-9 Affinity Matrix for Dining Room	3-13
3-10 Relationship of Dining to Other Spaces	3-14
3-11 Planning Dimensions for Bar	3-16
3-12 Affinity Matrix for Bar	3-18
3-13 Relationship of Bar to Other Spaces	3-16
3-14 Summary of Kitchen Activities	3-19
3-15 Planning Dimensions for Kitchen Tables	3-20
3-16 Planning of Delivery and Receiving	3-22
3-17 Relationship of Meat Preparation to Other Areas	3-26
3-18 Relationship of Vegetable Preparation Area to Other Areas	3-27
3-19 Relationship of Salad Preparation Area to Other Areas	3-28
3-20 Relationship of Cooking Area to Other Areas	3-30
3-21 Affinity Matrix for Kitchen	3-37
3-22 Relationship of Kitchen to Other Areas	3-38
3-23 Planning Dimensions of Layout for Bingo	3-40
3-24 Affinity Matrix for Multi-use	3-44
3-25 Affinity Matrix for Party Room	3-47
3-26 Relationship of Party Room to Other Spaces	3-48
3-27 Affinity Matrix for Quiet Recreation	3-50
3-28 Relationship of Quiet Recreation Room to Other Spaces	3-50
3-29 Affinity Matrix for Noisy Recreation	3-52
3-30 Relationship of Noisy Recreation Room to Other Spaces	3-52
3-31 Planning Dimensions for Layout of Office Spaces	3-54
3-32 Affinity Matrix for Administration	3-56
3-33 Affinity Matrix for Rest Rooms	3-58
3-34 Affinity Matrix for Storage	3-60
6-1 Range of Design Images for Single Plan	6-16

1-1 PURPOSE.

1-1.1 This guide contains design criteria for Army officers and NCO clubs, formerly referred to as open messes, and referred to below as clubs.

1-1.2 The primary purpose of this guide is to provide criteria for design personnel who prepare and evaluate project designs for clubs.

1-1.3 This guide also provides general guidance for installation personnel and Corps of Engineers field offices in planning and programming project requirements.

1-1.4 In addition, it is expected that facility managers will find this guide useful in planning improvements or in better utilizing existing clubs or other suitable facilities.

1-1.5 This guide is directed toward improving early design decisions and toward the development of realistic, cost-effective spaces. The guide does not provide definitive designs; it is intended as a tool to help solve problems in ways which incorporate individual local requirements.

1-2 PRIMARY REFERENCES.

- a. DOD 4270. 1-M, DOD Construction Criteria Manual.
- b. AR 230-60, Management and Administration of the U. S. Army Club System.
- c. AR 415-10, General Provisions for Military Construction.
- d. AR 415-15, MCA Program Development.
- e. AR 415-17, Empirical Cost Estimates for Military Construction.
- f. AR 415-20, Project Development and Design Approval.
- g. DA PAM 230-1, Open Mess Management and Operations Manual.

1-3 SCOPE.

1-3.1 This design guide is applicable to all new construction projects for Army clubs. It is also applicable, as general guidance, to projects involving the modernization of existing facilities.

1-3.2 While this guide is the basic design criteria document for clubs, it is not intended to provide all of the information required for successful preparation of project designs. Additional information must be obtained from the unique requirements at the installation level which are associated with the general description of activities contained herein and the locational constraints and opportunities of the site.

1-3.3 Maximum space allowances for clubs are discussed in DOD 4270. 1-M, Construction Criterial Manual, Chapter 3. These allowances are based on the authorized projected military strength of the using installation. illustrative criteria applications are included herein for various sizes of clubs corresponding to installations with the following military strengths:

<u>Military Strength</u>		<u>Facility Gross Square Foot Area</u>
Officers	NCOs	
151-250	401-750	15,649
29		1,276
151-250		7,806
1001-2000		25,494
	401-750	9,217
	1251-2000	17,609
	2000-3000	26,051

1-3.4 The illustrative criteria applications provide schematic design solutions to the example space programs. These schematic designs illustrate alternative planning solutions, following the criteria in this guide. Alternative detailed planning solutions for specific functional areas of the facility are also shown.

1-4 EMPHASIS.

1-4.1 Special emphasis shall be placed on the quality of architectural design since it vitally affects the longevity, economics, usefulness, and efficiency of clubs. In addition to considerations of life cycle economy and functional efficiency, a prime requirement of the architectural design shall be the attractiveness of both the interior and exterior facilities.

1-4.2 In selecting architects for the design of these facilities, consideration should be given to the following factors:

- a. A continuing experience in design of restaurants, clubs and similar facilities.
- b. A demonstrated imaginative approach to building design.
- c. Experience with modern, flexible construction systems.

1-4.3 An overall interior design scheme should be developed in conjunction with the building design of all new facilities and of major alterations to existing facilities.

1-4.4 As part of the overall design, a users information book should be assembled to help provide instructions on maintaining and operating the facility to maximum advantage. The book should cover major design intentions for the utilization of the facility and its interior spaces, and related information concerning environmental controls, mechanical facilities and housekeeping in general.

1-5 RESPONSIBILITIES.

1-5.1 The using service for individual MCA projects is defined in AR 415-10, General Provisions for Military Construction, and its responsibilities are outlined in AR 415-20, Project Development and Design Approval. The using service is responsible for:

- a. Establishment of specific project functional requirements within the parameters set down in this guide.
- b. Justification of functional requirements falling outside the parameters of this guide.
- c. Obtaining installation action to gain site approval if the project is not sited in accordance with DA approved master plan.
- d. Preparation and submission of DD Form 1391 and supporting data in accordance with AR 415-15, MCA Program Development.
- e. Preparation and submission of project requirements in the form required by AR 415-20.
- f. Review and approval of concept design drawings to certify compliance with functional requirements.

1-5.2 The Corps of Engineers field office responsible for design will:

- a. Insure that the functional requirements of the using service are incorporated into the design.
- b. Insure that the requirements of the using service meet the criteria contained herein.
- c. Insure that the quality standards for overall design are adhered to in accordance with the policy stated herein.
- d. Insure that the assemblage of user information is complete, and is provided, together with the completion records required by AR 415-10, to the using service.

2-1 THE CLUB CONCEPT.

2-1.1 GENERAL

2-1.1.1 Members and Activities: The Army club is a private organization established to provide dining and recreational facilities for its members. Eligible patrons include active and retired service men and women, their dependents, and authorized civilians of equivalent grade. Members of other military clubs are generally eligible for club privileges. Members pay dues, which may be flat rate or pro-rated by rank. The major club activity, and its major source of revenue, is the provision of meals and beverage service for members. Bingo and evening dances, with live entertainment, are popular activities in most clubs. In addition, the club provides facilities for a variety of parties and meetings ranging from wedding receptions to bridge playing. These meetings will generally require food and beverage service.

2-1.1.2 The Role of the Club: A well-managed and attractive club will play a significant role in maintaining installation morale. The club is the off-duty social center for its members and is the place on the installation which most approximates the civilian environment. The Army club is an unusual military facility in that it must produce revenue and support itself, in a way similar to its civilian counterparts, and is in competition with comparable facilities outside. On a remote installation this competition may not be significant, but for those installations located near major cities, civilian competition has a significant bearing on the club operation.

2-1.1.3 The Club Facility: The club facility establishes the character of the club and should appeal not only to the off-duty serviceman, but to his wife or date, and to civilian guests. A large club must provide a wide variety of atmospheres, from a cheerful informal bar to a dignified formal dining room comparable to the best hotel in town. Location, site planning and landscaping also play an important role in reinforcing the attractiveness of the club.

2-1.1.4 The Club and the Community: The Army club also plays a role in the community beyond the base. The club may be used for community events, meetings of local interest groups and the like. To the extent this is done, the club improves its earning situation and serves as a community resource; however, the facility and its operation must respect first the needs of its own membership. To the extent that the club welcomes civilian guests and community activities, it represents the Army to the civilian population and community, and as such can assist significantly in presenting a favorable image.

2-1.2 CLUB ACTIVITIES

2-1.2.1 Summary of Activities: The activities of the typical club are summarized in Table 2-1. Clubs may emphasize one activity as against others depending on local management and membership taste.

Table 2-1 Typical Club Activities

formal - waitress service	dining
buffet	
snack	
cafeteria	
outside service	
Staff	
catering on installation	
at bar	beverage service
at table	
outside service	
catering on Installation	
formal	dancing
folk	
rock	
ethnic	
individual entertainers	performance
bands	
bingo	games
pool	
bridge	
amusement machines	
t.v. watching	recreation, indoor
writing	
talking	
Office activities	administration
accounting	
document reproduction	
food	receiving
Liquor	
goods	
food	storing
Liquor	
goods	
food	preparing
beverages	
food	serving
beverages	
Liquor (package)	selling
other	
parties	special activities
weddings	
large with meal	
small with meal	
cleaning	maintenance
repairing	
replacing	
changing building	
moving equipment	
moving typical supplies	
circulating point to point	circulation
circulating at random	

2-1.2.2 Change: The club is a dynamic institution that reflects the social changes around it, expressed in habits of dress, relationship and activity. In addition, military installations are subject to long-term growth or shrinkage and are often subject to change through high-level policy decisions. The club facility must be designed to be adaptable both to evolving social changes and to changes in size and type of membership. The club must be easy to remodel, easy to expand, and easy to contract, with spaces that are readily adaptable to other uses.

2-1.3 CLUB USERS

2-1.3.1 Summary of Users: Officers and NCO club users are summarized in Table 2-2 and 2-3. It can be seen from Table 2-2 and Table 2-3 that club users form a large number of groups, and each group has its own set of needs and desires that the club must try to satisfy. In this, the club differs from its civilian counterpart which generally can cater to a narrower range of users, with consequent simplification of facility planning and club operation. The two most significant groups which affect the planning of the club are the senior and junior members. In general, senior members are more comfortable in a formal atmosphere, while junior members are more responsive to the informal and egalitarian trends in civilian life. To the extent that separate activities and facilities can be maintained for these two significant groups, club membership and revenue will benefit. The smaller club will be forced to compromise--at least in facilities--between the demands of these two groups. In large clubs the problem has been most successfully resolved by completely separate facilities, in which the main club for the senior members is supplemented by separate, informal facilities aimed at the needs of the younger members.

Table 2-2 Officers Club Users by Age Group

Age	18-24	25-34	35-44	45-59	60+
Active Duty officers					
Retired officers					
Civilian employees					
Wives					
Widows					
Guests, male					
Guests, female					

Table 2-3 NCO Club Users by Age Group

Age	18-24	25-34	35-44	45-59	60+
Active Duty NCOs					
Retired NCOs					
Civilian employees					
Wives					
Widows					
Guests, male					
Guests, female					

2-1.3.2 Women Users: Women are another significant group with specific needs. In general the number of women service personnel on an installation is small. A successful club is attractive to women members and guests, since its revenue is significantly affected by the extent to which male members feel inclined to take their wives or dates to club activities. The same generation gap also applies here, for the rock band and the swinging informal bar atmosphere appropriate to the junior member's date may not appeal to the senior member's wife.

2-1.3.3 Other Users: Civilian employees, whose number at a large base may be considerable, are also a special group to whom to appeal, and their age level will also affect their demands. Children are not a significant user group, for the club by and large is an adult-oriented facility. At the other end of the scale, retired officers and their dependents form a significant user group in some locations. Where this is so, provision for the handicapped will be of special concern. The split in tastes between the young members and retired service members is even greater than that between junior and senior active service members.

2-2 PLANNING THE CLUB.

2-2.1 GENERAL

2-2.1.1 Officers and NCO Clubs

- A. Similarities: The functional requirements for officers and NCO clubs are similar and the planning problems encountered in both are identical.
- B. Program Differences: More dining area relative to bar area is provided in the officers club than in the NCO club. This program variation is detailed in the program development section (Section 2-2.3).
- C. Character Differences: Officers clubs will generally have a more formal design image, both exterior and interior, than the NCO club. The officers club will generally be used for important visitors to the installation, and plays an important role in expressing the desired character of the installation.

2-2.1.2 Joint Club Facility

- A. Description: The joint club facility refers to a single facility designed to accommodate both the officers and NCO clubs. This type of facility has been developed in response to escalating costs of construction and operation. Economics are realized by facilities sharing one kitchen, and administration space can be reduced.
- B. Planning: The joint club facility must be planned so that privacy is maintained between officers and NCO facilities. Entrances should be separated and planning should be arranged so that, within the building, officers and NCOs do not cross paths.

2-2.1.3 Trends

- A. Remodeled Facilities: Increasing construction costs will tend to result in increased use of remodeled facilities for clubs. The same programming and planning requirements apply as to a new facility; however, more specialized design skills may be necessary to provide attractive and functional space. A remodeled facility may provide spaces and an atmosphere that, utilized imaginatively, can be superior to that of a new facility.

- B. Adaptability: Many clubs in the last few years have had to adapt to a declining enrollment caused by the overall reduction in the military establishment. At the same time installation closings may result in consolidation and an abrupt increase in membership at another installation. These trends require facilities that can adapt both to expansion and contraction. Particular attention should be paid to planning those areas in the club that are most likely to expand or contract, and structural systems in particular should be selected with a view to their adaptability to changing functional requirements.

2-2.2 SPACE CLASSIFICATION

2-2.2.1 General: The format of the space description establishes three classifications of space as shown in Table 2-4. Key numbers are assigned to each space. All plans and sections in this guide are keyed using the same numbers.

2-2.2.2 Generic Space: The club spaces are classified into 14 generic spaces. The main basis for this classification is the identification of distinct functional, environmental and spatial requirements for each generic space.

2-2.2.3 Space Types: Where appropriate, generic space is broken down into variations of the generic space. The basis for this breakdown is the identification of distinct requirements for the space type within the generic space requirements. Not all generic spaces are accompanied by space type variations.

2-2.2.4 Sub-spaces: This classification represents specific functional spaces within the generic space, or spaces that are closely associated with it. In general, sub-spaces represent functions that always occur in relation to the generic space.

2-2.3 SPACE PROGRAM DEVELOPMENT

2-2.3.1 Determining Gross Floor Area: Two basic situations will be encountered in the development of space programs. The first is the development of a space program for a new facility, for which no managerial or operational experience exists. The second situation is the programming of a replacement facility or addition, for which operating history of the existing club will be available. In both instances the initial program activity requires the establishment of a gross floor area for the facility.

Table 2-4 List of Spaces

<u>Generic Space</u>	<u>Space Type</u>	<u>Sub-Space</u>
1 - Entry		coat room telephone room
2 - Dining Room		serving counter maitre'd station cashier station waitress station service bar telephone facilities
3 - Bar	cocktail lounge informal bar stag bar service bar mobile bar	storage
4 - Kitchen		delivery & receiving storage preparation cooking holding & serving clean-up & dishwashing staff facilities
5 - Ballroom/Multi-Use		dressing rooms
6 - Party Room		
7 - Recreation Room, quiet (Q)	reading room t.v. room, lounge	
8 - Recreation Room, noisy (N)		
9 - Administration Space	office, cashiers office, reproduction	
10 - Rest Room	toilet - men's women's power room - women's	
11 - Storage	general - tables & chairs garbage	
12 - Maintenance space	shop, janitor's closet	
13 - Mechanical Space	mechanical room electrical room compressor room	
14 - Locker Room	staff locker room - men's women's	

- A. New Facility: DOD Construction Criteria Manual 4270.1-M specifies maximum allowable gross areas for officers and NCO clubs. In the absence of any other information, such as operational projections to establish the number of meals to be served in the dining room, tables 2-5 and 2-6 may be used to establish a gross square foot area for the facility based on the military strength as defined in DOD 4270.1-M. With the gross floor area established, the criteria can be used to develop a space program for each generic space.
- B. Replacement Facility, or Addition: The space program for a replacement facility or addition must be worked out in concert with the management of the existing facility, who must provide estimates of utilization of critical activities in the new club. These figures can be derived from past history of the club, plus judgments as to increased patronage anticipated when the new facilities are completed.
- c. Critical steps for space programming are:
 - 1. Estimate average number of meals and types of service" to be provided by dining room at each meal. From this, the size of the dining room can be established, as described in Section 3-2.
 - 2. Size of kitchen can be established from the size of dining room, as described in Section 3-4.
 - 3. Estimate average attendance at functions in multi-use space, particularly dances and bingo. From this estimate, the size of the multi-use space can be established, as described in Section 3-5.
 - 4. Estimate frequency and size of party and meeting functions to be accommodated. From this estimate, the requirement of separate party and recreation rooms can be established, as described in Sections 3-6, 3-7, 3-8.
 - 5. The dining room, multi-use, party rooms and quiet and noisy recreation rooms represent the revenue producing spaces of the club. Estimate gross area of the club as equal to area of revenue producing spaces x 2.
 - 6. With major spaces established, and gross area established, remaining spaces can be programmed on basis shown in tables 2-5 and 2-6.

7. Where estimated gross area exceeds allowances in DOD 4270.1-M, a space exception must be requested by the using service.

Table 2-5 Sizing for Generic Spaces: Officers Clubs

Generic Spaces	
1 - Entry	5% of gross floor area
2 - Dining Room	*based on meals served
3 - Bars.	7-12% of gross floor area
4 - Kitchen	*based on size of dining room
5 - Multi-use	20-25% of gross floor area
6 - Party Room	*
7 - Rec. Room (Q)	3-5% of gross floor area
8 - Rec. Room (N).	*
9 - Administration	*0-5% of gross floor area
10 - Rest Rooms	3-4% of gross floor area
11 - Storage	2% of gross floor area
12 - Maintenance	1-3% of gross floor area
13 - Mechanical	4-5% of gross floor area
14 - Lockers	*
Circulation	*not to exceed 10% of gross floor area
* See criteria for each generic space in Section 3 for further details of sizing basis.	

Table 2-6 Sizing for Generic Spaces: NCO Clubs

Generic Spaces	Sizing Basis Allowance
1 - Entry	5% of gross floor area
2 - Dining Room.	*based on meals served
3 - Bars	10-15% of gross floor area
4 - Kitchen	*based on size of dining room
5 - Multi-use	20-25% of gross floor area
6 - Party Room	*
7 - Rec. Room (Q)	3-5% of gross floor area
8 - Rec. Room(N)	*
9 - Administration	*0-5% of gross floor area
10 - Rest Rooms	3-4% of gross floor area
11 - Storage.	2% of gross floor area
12 - Maintenance	1-3% of gross floor area
13 - Mechanical.	4-5% of gross floor area
14 - Lockers	*
Circulation	*not to exceed 10% of gross floor area
* See criteria for each generic space in Section 3 for further details of sizing basis.	

2-2.3.2 Space Program Examples: To demonstrate the use of the guide, seven examples are shown in Section 7 exemplifying small, medium and large officers and NCO clubs, and one joint club facility.

3-1.1 ACTIVITIES AND USES ANTICIPATED: Waiting, greeting guests, obtaining information on club activities, orientation to other areas of club, checking coats and bags, telephoning.

3-1.2 CHARACTER OF SPACE: The entry is the first space the club member or visitor encounters; it should express the character of the club. Main entry may be used for formal events and should present a dignified, though not stuffy image. Secondary entries should express an appropriate character: e.g., informal for an informal bar or lounge, clean and functional for a service area.

3-1.3 DIMENSIONAL CHARACTERISTICS

3-1.3.1 Governing Dimensions

- A. Horizontal Dimensions: no specific requirements
- B. Vertical Dimensions: no specific requirements, depends on character desired.

3-1.3.2 Sizing of Spaces: Allow 5% of gross floor area, exclusive of lounges, for aggregate of all entries.

3-1.4 BASIC EQUIPMENT REQUIRED

3-1.4.1 Comfortable chairs and low tables in waiting areas

3-1.4.2 Ashtrays for smokers. Recess ashtrays in walls in waiting areas and hallways for smokers who are standing.

3-1.5 REQUIREMENTS OF SUB-SPACES WITHIN MAIN SPACE

3-1.5.1 Coat Room

- A. Coat room should directly adjoin the entry lobby, or relate to adjoining hallways on the route to the dining room and main ballroom.
- B. Room should provide hanging racks for coats, shelves for bags, and a checking desk that can be closed off.
- C. Room should have a single lockable entrance for security.
- D. Size coat room for 50% of peak estimated patronage.
- E. Coat racks provide for five garments per lineal foot.
- F. Planning dimensions as in Figure 3-1.

Figure 3-1 Planning Dimensions for Coat Room

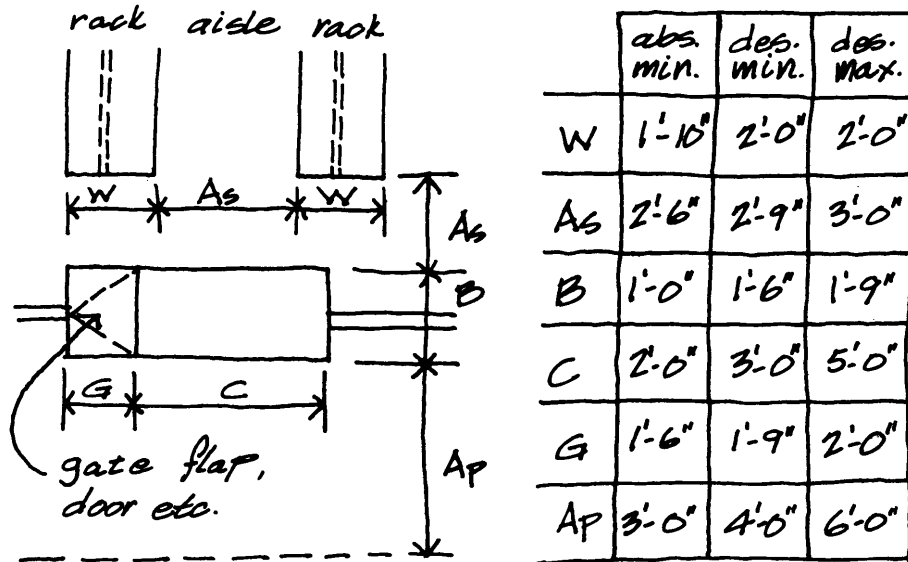

3-1.5.2 Telephone Rooms: Pay telephones should be provided next to the entry, or off an adjoining hallway. (See Section 3-2.5.11)

3-1.6 PLANNING CRITERIA

3-1.6.1 Provide uncluttered space, with clear routes to other parts of the club.

3-1.6.2 Provide, preferably, column free space.

3-1.6.3 Waiting space, and furniture, should be to the side of the main circulation routes.

3-1.6.4 In a large club, provide a lounge area, adjoining or as part of the entry, which may be used for waiting and for the greeting of guests at formal functions.

3-1.6.5 In a large club, provide a separate reception desk.

3-1.6.6 In a large club, provide a separate cashier's office located adjoining, but not directly within, the entry.

3-1.6.7 In a small club, place cashier's office in the entry hall, enabling clerical staff to act as receptionist.

3-1.6.8 Provide tack space adjoining cashier's office for display of club financial statements.

1 - ENTRY

3-1.6.9 Assist orientation by well-designed signs indicating directions to other parts of the club. (See Section 6-4.3.6)

3-1.6.10 Provide tack space for advertisements of club functions.

3-1.6.11 Provide rest rooms off hallway adjacent to entry.

3-1.6.12 Provide door closers or automatic doors in order to control drafts.

3-1.7 GENERAL ENVIRONMENTAL PERFORMANCE REQUIREMENTS

3-1.7.1 Lighting

- A. Natural: Natural lighting is not necessary for functional purposes, but a view out is desirable adjoining the entrance doors, so that exiting guests are aware of weather conditions.
- B. Artificial: General level: 30 f.c. Notice boards, signs, etc. : 50 f.c.

3-1.7.2 Acoustics

- A. Sound, Generation: Noisy area when crowded, at other times entry is quiet.
- B. Sound, Isolation: Need not be isolated from other areas.

3-1.7.3 Thermal

- A. In circulation areas comfort conditions should be maintained equivalent to working areas. Provide 5-8 air changes/hour.
- B. Waiting areas should maintain comfort conditions equivalent to living and administrative areas. Provide 8-10 air changes/hour.
- C. Protection is necessary from outside drafts, particularly near the entry doors.

3-1.8 RELATIONSHIPS TO OTHER SPACES: See Figures 3-2, 3-3, and 3-4.

Figure 3-2 Affinity Matrix for Entry

The affinity matrix indicates relationships between space 1 - Entry and other generic spaces as being required or desirable (+), of no consequence (0), or undesirable (-).

	2 - Dining Room	3 - Bar	4 - Kitchen	5 - Multi-use	6 - Party Room	7 - Rec. Room (Q)	8 - Rec. Room (N)	9 - Administration	10 - Rest Rooms	11 - Storage	12 - Maintenance	13 - Mechanical	14 - Lockers
1 - Entry	+	+	-	+	0	-	-	+	+	0	-	-	-

Figure 3-3 Relationship of Entry to Other Spaces (Small Clubs)

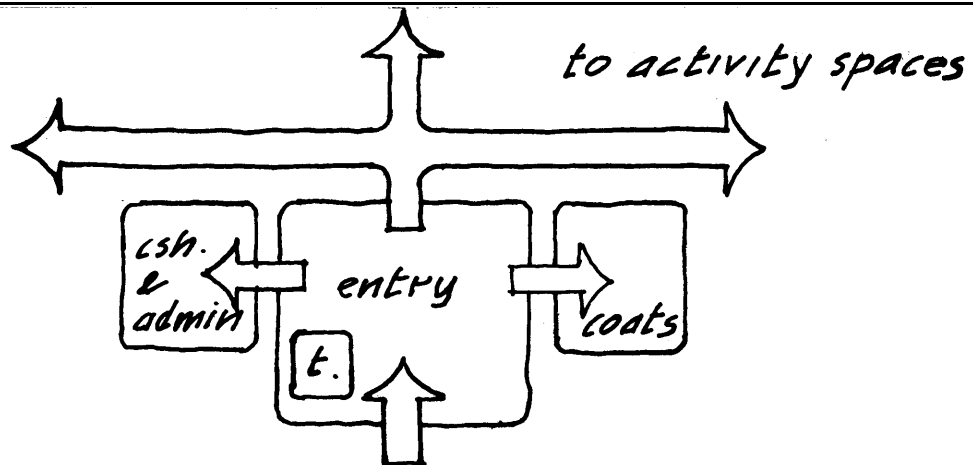

t. = telephones
csh. = cashier

- sub-spaces adjoin entry
- telephone within entry

1 - ENTRY

Figure 3-4 Relationship of Entry to Other Spaces (Large Clubs)

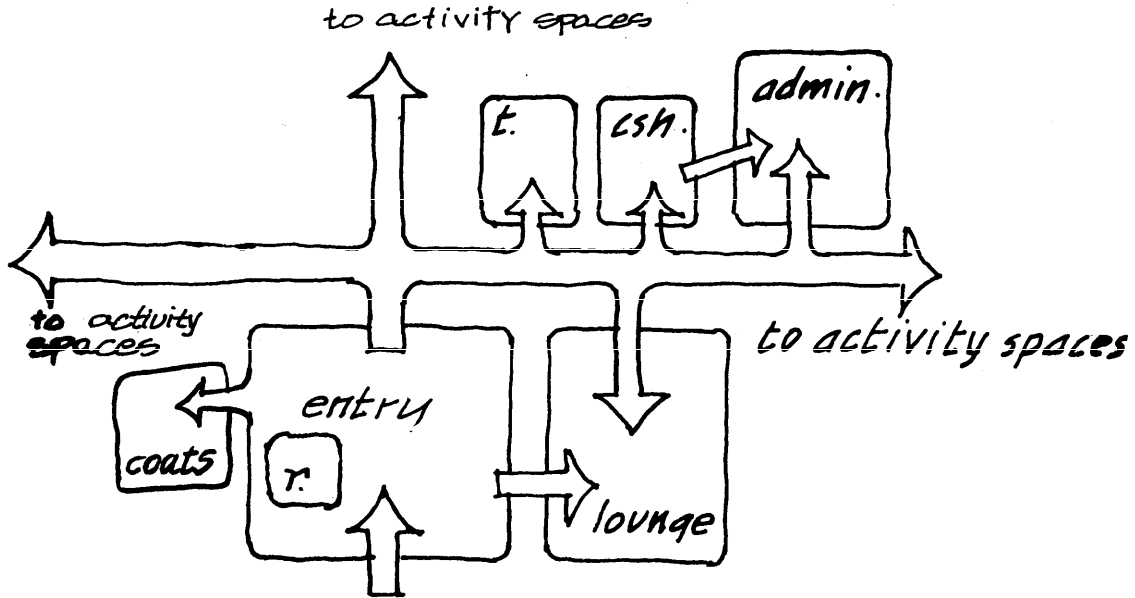

t. = telephones
r. = reception
csh. = cashier

- sub-spaces adjoin exit hallways to other spaces
- lounge adjoins entry

3-2 DINING

3-2.1 ACTIVITIES AND USES ANTICIPATED: Breakfast, lunch and dinner service for club members. Lunch is typically cafeteria or scramble service, but a large club may also provide table service. Dinner is typically table service. Service variations provided, according to size and local management, may include a sandwich or do-it-yourself steak service at lunch. Dinner may include a sandwich service, and special meal service nights (e.g., Italian, Chinese, French, German, Luau, etc.)

3-2.2 CHARACTER OF SPACE: Decor may vary greatly according to local taste and management, but a subdued traditional atmosphere is typical. Low general lighting levels may be effectively supplemented by table lighting. The dining space should be visually subdivided into groups of 30-40 people to provide a more intimate atmosphere; this is particularly important with a very large dining room. A variety of dining arrangements is also desired--tables for two, four, or six. It is useful to provide tables for two that can easily be arranged into tables for four or six.

3-2.3 DIMENSIONAL CHARACTERISTICS

3-2.3.1 Governing Dimensions

- A. Horizontal Dimensions: Governed by requirements of table, chair, and equipment locations, together with staff and circulation space. See Figures 3-5 and 3-6. Maximum aspect ratio: 2:1. (Aspect ratio is defined as the ratio between the length and width of a rectangular space.)
- B. Vertical Dimensions: Minimum ceiling height 10'-0".

3-2.3.2 Sizing of Spaces

- A. Overall size of dining room established on following basis:
 - 1. Estimate number of meals to be served.
 - 2. Estimate number of sittings per meal.
 - 3. Assume 80% occupancy per sitting to establish number of seats. Thus, number of seats is 125% number of meals.
 - 4. Allocate area/seats as follows:

15 s.f./seat*	high standard
14 s.f./seat*	good standard
13 s.f./seat*	banquet seating

* includes area for aisles

Note that Figures 3-5 and 3-6 show examples of minimal dimensions of table space layout. In practice, layouts adhering to the allowances above have been found to provide appropriate space.

B. Area Computation Example:

1. Estimate 600 meals served.
2. Assume 2 sittings.
3. At 80% occupancy, 300 meals/sitting, requires 375 seats. (375 seats x 80% occupied = 300 meals)
4. Dining Room Area: $375 \times 15 = 5,625$ s.f. (high standard)

c. Size of service area for cafeteria service established as follows:

1. Maximum Rate: 10 persons/minute (governed by cashier)
2. Establish number of cashiers based on time for service, and overall number of meals to be served.
3. Allow 20-24 linear feet of serving counter/cashier.
4. Allow 20 s.f. area for each linear foot of serving counter.

D. Size of service area to be provided in kitchen for table service should be equivalent to cafeteria service above.

3-2.4 BASIC EQUIPMENT NEEDED: Tables, chairs, booths, carpet.

3-2.5 REQUIREMENTS OF SUB-SPACES WITHIN MAIN SPACE

3-2.5.1 Serving Counter: Cafeteria Serving counter may also be planned for use as waitress service area in the evening.

3-2.5.2 Cafeteria Planning:
Straight line systems. Most economical of space and equipment. Multiple straight line counters necessary for large dining room.

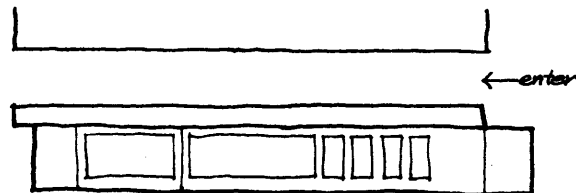

2-DINING

3-2.5.3 Cafeteria Planning:
Bypass line. Allows hot food counter to be bypassed.

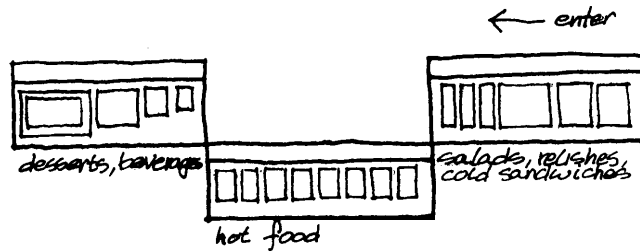

3-2.5.4 Cafeteria Planning:
Sawtooth. Patron may go direct to counter serving food of his choice. Most efficient way of utilizing long and narrow serving area.

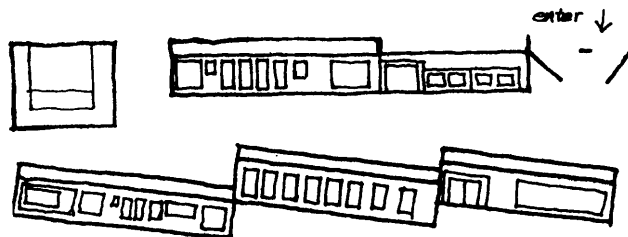

3-2.5.5 Cafeteria Planning:
Scramble System. Best system for high speed, large-scale service. Speed of service determined by number of cashiers. Overall area required greater than that for other types of service.



3-2.5.6 Typical Cafeteria Counter Dimensions:

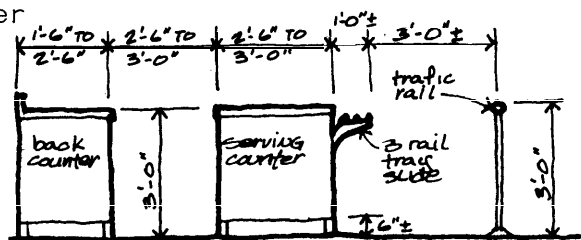

3-2.5.7 Maitre'd Station

- A. Locate at entrance to dining room, on right hand side of door when entering.
- B. Provide stand-up desk, light, telephone.

3-2.5.8 Cashier's Station

- A. Locate at entrance to dining room, on left hand side of door when entering.
- B. Provide for cash register.
- C. Provide for merchandise such as cigars, cigarettes, which may be sold by the cashier.
- D. Planning dimensions are as shown in Figure 3-7.

Figure 3-7 Planning Dimensions for Cashier's Station

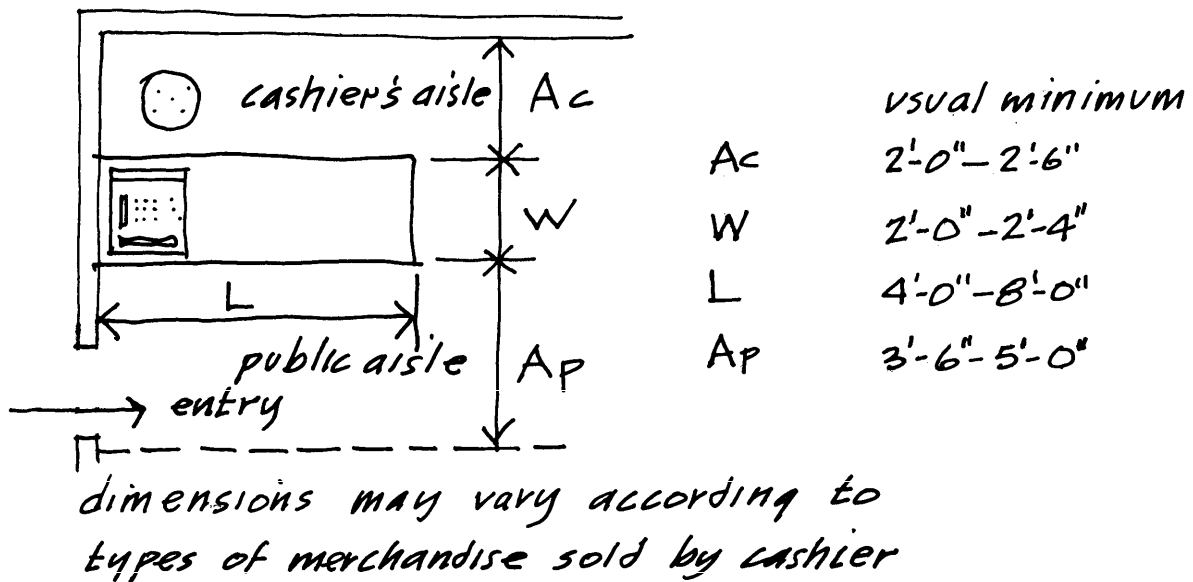

3-2.5.9 Waitress Station

- A. Provide serving table for waitresses adjoining kitchen service area, and placed around dining room on basis of one station/30 seats.
- B. Table should provide room for coffee maker.
- C. Size station as shown in Figure 3-8.

2-DINING

Figure 3-8 Planning Dimensions for Waitress Station

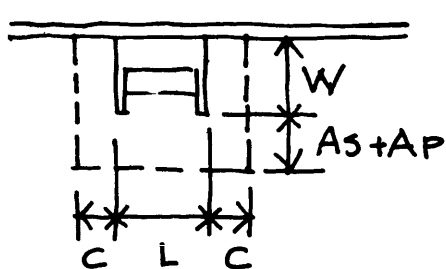

As	service only	2'-6" - 3'-0"
AP	public circulation	2'-0" - 2'-6"
C	clearance to adjacent units	2'-0" - 2'-6"
L	counter length	2'-6"
W	counter width	1'-8"

3-2.5.10 Service Bar

- A. Locate adjacent to or within the kitchen.
- B. View of service bar should be concealed from patrons.
- C. See description of generic space 3 - Bar, for further information on service bar.

3-2.5.11 Telephone Facilities: Telephone booths should be out of direct vision, yet convenient to dining areas. Provide one telephone booth per 125 seats in dining room. (See Section 3-1.5.2)

3-2.6 PLANNING CRITERIA

3-2.6.1 The dining room should be on the same floor level as the kitchen.

3-2.6.2 A dining room with waitress service should have provision for a waiting area at the entrance that can be controlled by a maitr'd.

3-2.6.3 The cocktail bar is appropriately planned adjoining the dining room, and can be used as a waiting area at busy times.

3-2.6.4 The dining room may adjoin multi-use and, by use of movable walls, may accommodate overloads of either dining or multi-use activities

3-2.6.5 In smaller dining room, where no service bar is provided, provide direct waitress access to main bar.

3-2.6.6 Provide for coat checking, either by use of the coat check at the main entry, or by separate small coat check space at dining room entry.

3-2.6.7 In cafeteria provide coat trees for self-checking of coats and belongings.

3-2. 6.8 Seating arrangements should make maximum use of tables for two that can also be combined to make tables for four or six.

3-2.7 GENERAL ENVIRONMENTAL PERFORMANCE REQUIREMENTS

3-2.7.1 Lighting

- A. Natural: Provide windows if view is attractive.
- B. Artificial: Provide atmospheric lighting. Low general level, supplemented by lighting at tables. Incandescent lighting is appropriate. See table 4-7 for standards.

3-2.7.2 Acoustics

- A. Sound, Generation: Considerable conversational sound. Provide absorption in floor, ceiling and walls.
- B. Sound, Isolation: Not essential.

3-2.7.3 Thermal: Variable occupancy area. System should provide good comfort conditions for wide range of occupancy and should have quick response. Primarily sedentary activities, thus freedom from drafts important. Provide 12-15 air changes/hour for cafeteria service and 8-12 air changes/hour for restaurant service.

3-2.8 RELATIONSHIPS TO OTHER SPACES: See Figures 3-9 and 3-10.

Figure 3-9 Affinity Matrix for Dining Room

The affinity matrix indicates relationships between space 2 - Dining Room and other generic spaces as being required or desirable (+), of no consequence (0), or undesirable (-).

	1 - Entry	3 - Bar	4 - Kitchen	5 - Multi-use	6 - Party Room	7 - Rec. Room (Q)	8 - Rec. Room (N)	9 - Administration	10 - Rest Rooms	11 - Storage	12 - Maintenance	13 - Mechanical	14 - Lockers
2 - Dining	+	+	+	0	0	-	-	-	-	+	-	-	-

2-DINING

Figure 3-10 Relationship of Dining to Other Spaces

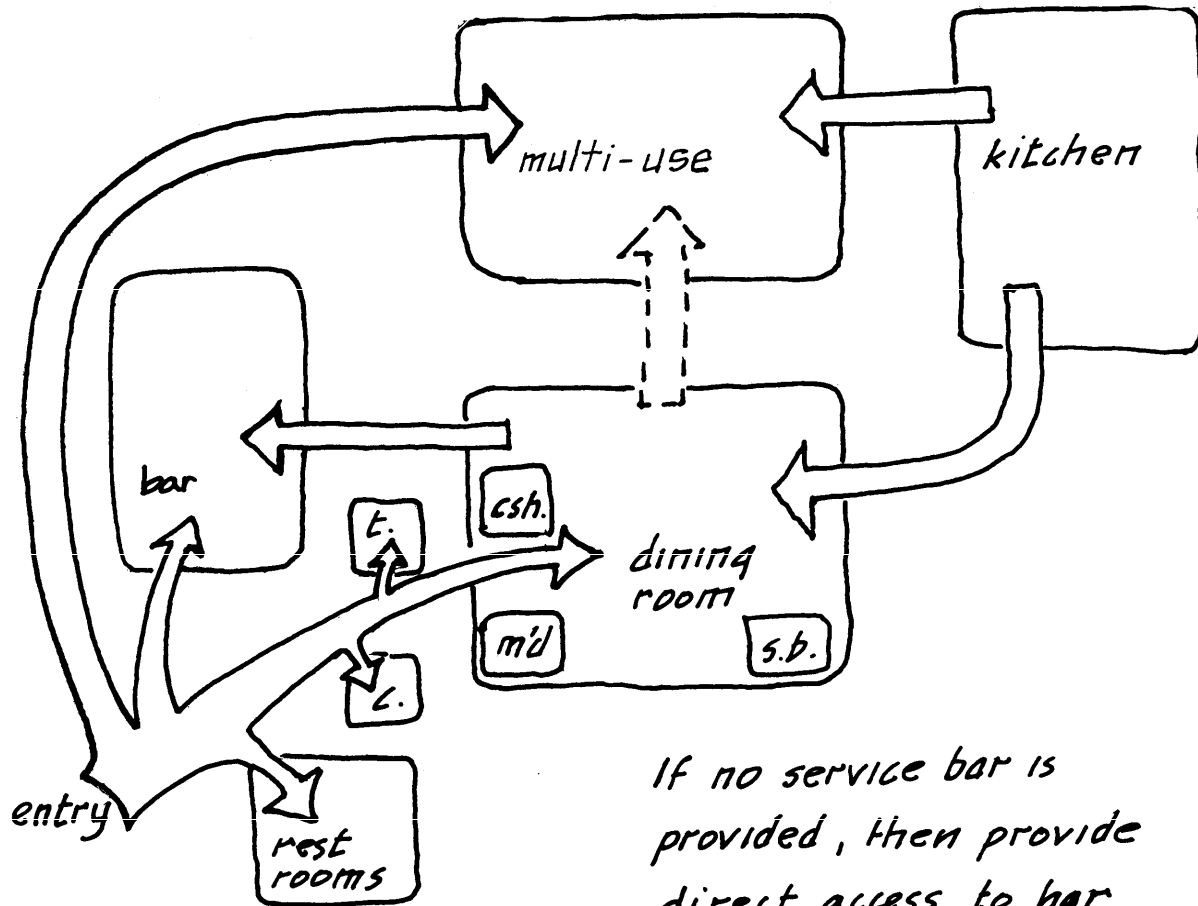

If no service bar is provided, then provide direct access to bar from dining room

t = telephones

csh. = cashier

m'd = maitre d'

c = coat room

s.b. = service bar

---> = desirable but not essential link

3-3 BAR

3-3.1 ACTIVITIES AND USES ANTICIPATED

3-3.1.1 Beverage service, dancing, entertainment, and the opportunity to meet and socialize with fellow members in an informal setting.

3-3.1.2 The service bar is a small bar associated with the dining room or multi-use space for the provision of bar service to that room. The service bar should be designed as a self-sufficient bar which is stocked periodically from the main bar storage.

3-3.1.3 Mobile bars are used in multi-use and party rooms where no service bar is provided.

3-3.2 CHARACTER OF SPACE

3-3.2.1 Bar should be an attractive informal space. The atmosphere should be warm and discreet, and there should be opportunity for a variety of group sizes to be easily accommodated, ranging, from the solitary drinker to a large group of a dozen or more.

3-3.2.2 Cocktail bar should be relatively conservative in character and attractive to female guests.

3-3.2.3 Informal bar is more casual in character and will be oriented more, though not exclusively, towards male patrons; dress will be casual. The informal bar will tend to appeal to younger members and guests. Contemporary decor is appropriate, but generally colors and lighting should be subdued.

3-3.2.4 A stag bar is for men only and may be quite cheerful, rough and homey in atmosphere: There should be more emphasis on bar as opposed to table service.

3-3.3 DIMENSIONAL CHARACTERISTICS

3-3.3.1 Governing Dimensions

- A. Horizontal Dimensions: Governed by table numbers, size and location, together with guest and staff circulation requirements. See generic space 2 - Dining Room for more information on table layout, and Figure 3-11 for bar layouts.
- B. Vertical Dimensions: Minimum ceiling height 10'-0".

3-BAR

Figure 3-11 Planning Dimensions for Bar

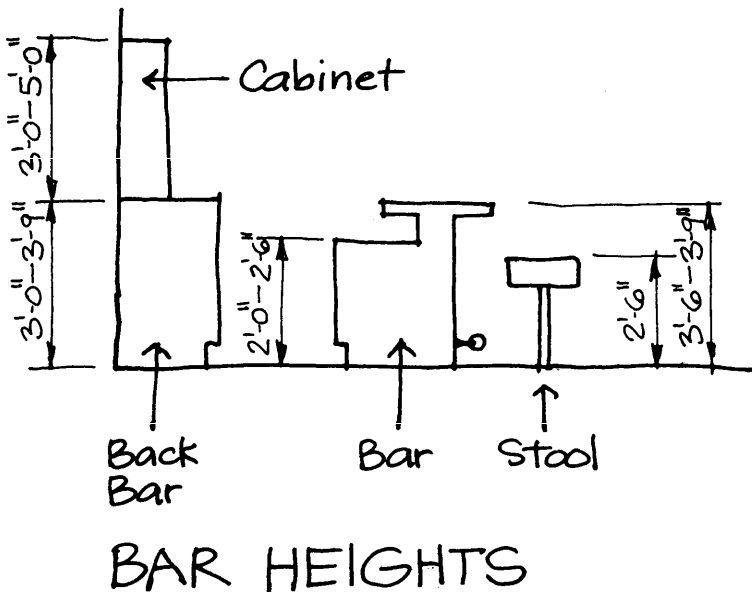
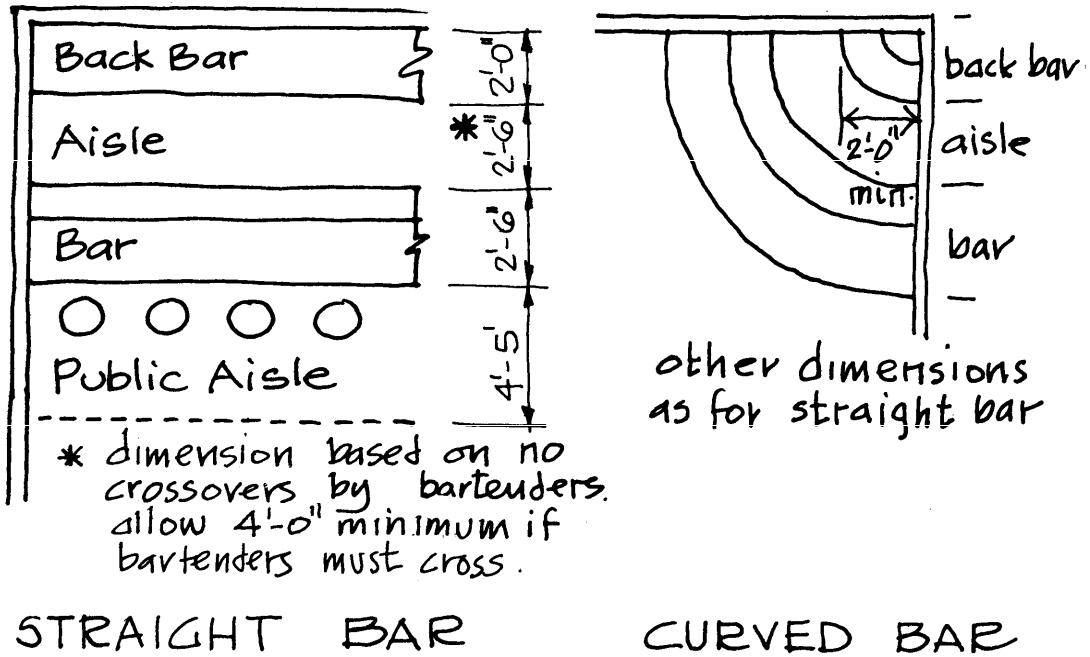

Bar Length:
Allow 2'-0" for each stool.

Service Bars:
6'-8' long for 1-man service.
10'-12' long for 2-man service.

3-3.3.2 Sizing of Spaces

- A. Size of overall bar areas may vary greatly depending on local tastes and management policies.
- B. Guideline for establishing size of aggregate bar areas: 7-12% of gross floor area.

3-3.4 BASIC EQUIPMENT REQUIRED: Tables, chairs, stools, bar equipment. Floor drain should be provided in back bar area.

3-3.5 PLANNING CRITERIA

3-3.5.1 Although service-at the bar will be available at all bars, the emphasis will be on table service, except in stag bar.

3-3.5.2 The cocktail lounge should have ready access to the dining room and may form an appropriate waiting area for this space.

3-3.5.3 A view to the outside is not important. However, the cocktail lounge may with advantage utilize an outside terrace court or deck if the view is attractive and the climate is amenable.

3-3.5.4 Rest rooms should be conveniently accessible to the bar area.

3-3.5.5 Different types of bars should be separated from one another, and preferably have completely separate entrances, since their patron's dress and habits may diverge.

3-3.5.6 Different bars may be appropriately planned on different floor levels.

3-3.6 GENERAL ENVIRONMENTAL PERFORMANCE REQUIREMENTS

3-3.6.1 Lighting: Should be subdued. Specific standards are not applicable.

3-3.6.2 Acoustic: Bars may sometimes be noisy, particularly the informal and stag bars.

3-3.6.3 Thermal: Ventilation should be good, and controls and systems should be able to accommodate a range from a few solitary drinkers to a noisy crowd. Provide 15-20 air changes/hour.

3-3.7 RELATIONSHIPS TO OTHER SPACES : See Figures 3-12 and 3-13.

3-BAR

Figure 3-12 Affinity Matrix for Bar

The affinity matrix indicates relationships between space 3 - Bar and other generic spaces as being required or desirable (+), of no consequence (0), or undesirable (-).

	1 - Entry	2 - Dining Room	4 - Kitchen	5 - Multi-use	6 - Party Room	7 - Rec. Room (Q)	8 - Rec. Room (N)	9 - Administration	10 - Rest Rooms	11 - Storage	12 - Maintenance	13 - Mechanical	14 - Lockers
3 - Bar	+	+	0	+	+	-	0	-	0	+	0	-	0

Figure 3-13 Relationship of Bar to Other Spaces

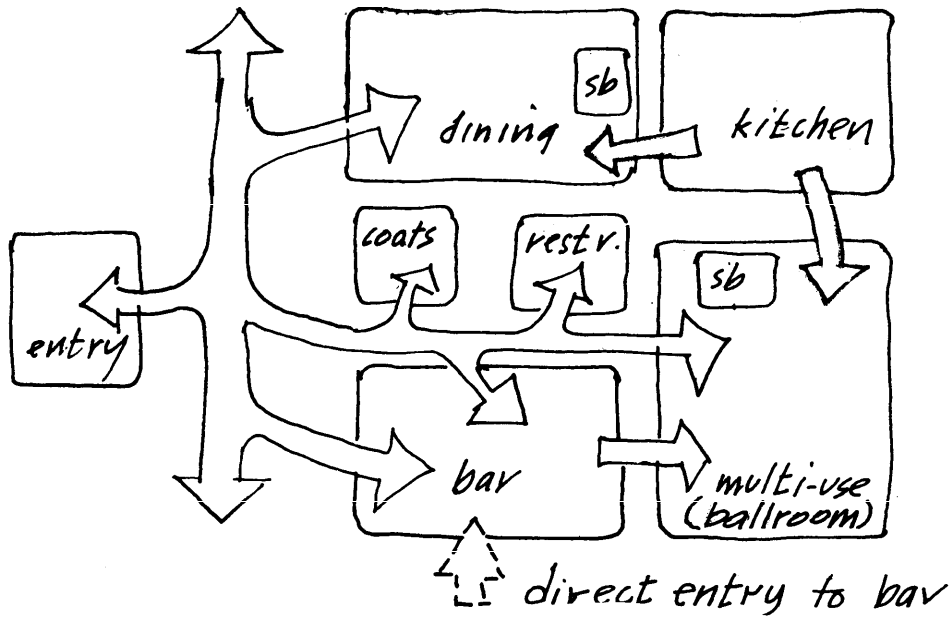

3-4 KITCHEN

3-4.1 ACTIVITIES AND USES ANTICIPATED: See Figure 3-14.

Figure 3-14 Summary of Kitchen Activities

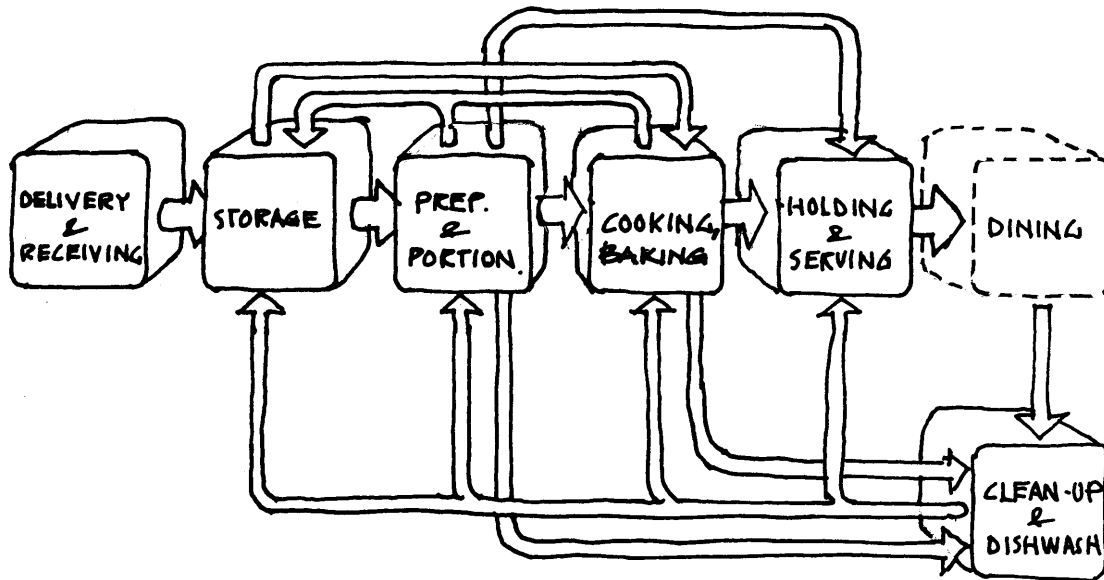

3-4.2 CHARACTER OF SPACE: Efficient, well-lit, functional and clean.

3-4.3 DIMENSIONAL CHARACTERISTICS

3-4.3.1 Governing Dimensions

- A. Horizontal Dimensions: Governed by requirements of equipment location and relationship, together with staff work and circulation. See Figure 3-15 for typical work space and aisle dimensions.
- B. Vertical Dimensions: Minimum ceiling height is 10'-0".

3-4.3.2 Sizing of Spaces

- A. The kitchen size has the following relationships to size of dining room and type of service:

Table Service	Dining/Kitchen area ratio	50/50
Cafeteria Service		55/45
Scramble Service		60/40

4-KITCHEN

It can be seen that table service places greatest demand on kitchen space. This is because the serving area in this type of service forms part of the kitchen area.

Figure 3-15 Planning Dimensions for Kitchen Tables

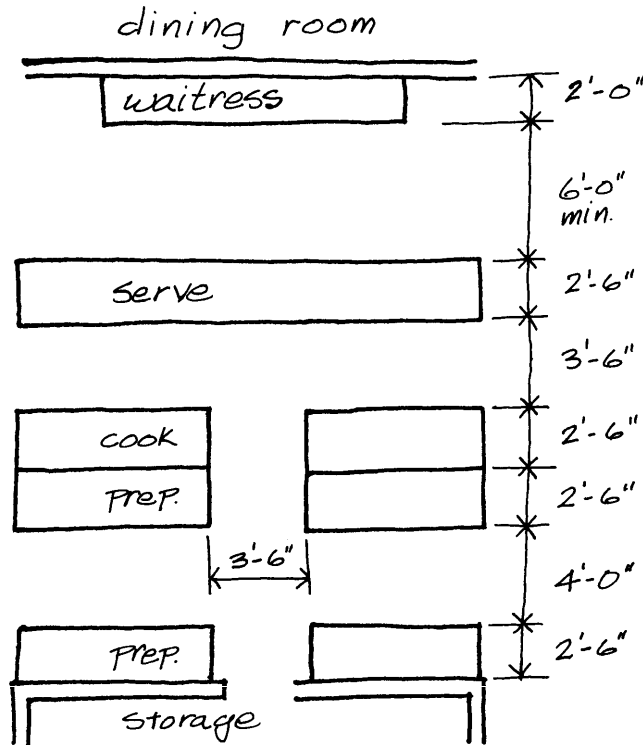

B. Effect of Banquet Space on Kitchen Size: Banquet space requires additional area for make-up, cart storage, plating, coffee stations, and refrigeration. This space is at ratio of 80/20, banquet/service. If kitchen is close to banquet area, this space is added to kitchen area and kitchen area is increased. If kitchen is removed from banquet area, this space is additional service area adjacent to multi-use, and main kitchen area remains same.

C. Area Computation Example:

Dining Room	1000 s.f.	
Kitchen (table service)	1000 s.f.	Ratio 50/50
Multi-use Rooms	1000 s.f.	
Multi-use Service	500 s.f.	Ratio 80/20

3-4.4 BASIC EQUIPMENT REQUIRED: Refer to Sub-Space Requirements.

3-4.5 SUB-SPACE: DELIVERY AND RECEIVING

3-4.5.1 Activities and Uses

- A. Delivery and checking-in of all kitchen items
- B. Area also generally used for garbage or trash removal.

3-4.5.2 Basic Data Required to be Predicted

- A. Frequency of deliveries--per week, per day
- B. Size of maximum, minimum delivery (lbs. and volume)
- C. Equipment
 - 1. Types of delivery container
 - 2. Bulk
 - 3. Prepackaged
 - 4. Pallet
- D. Form of Transport
 - 1. Handcarts
 - 2. Handtrucks
 - 3 . Fork Lifts
 - 4. Rolled in (barrels)

3-4.5.3 Planning Considerations and Relationship to Other Spaces: See Figure 3-16.

- A. Trash and Garbage: Area should be located near receiving area (an enclosed area is preferred with hard, easily washed floor surface).
- B. Doors: All exterior doors in this area should have self-closing devices, metal frames and fly screens.
- c. Provide hot water can wash and storage.

4-KITCHEN

Figure 3-16 Planning of Delivery and Receiving

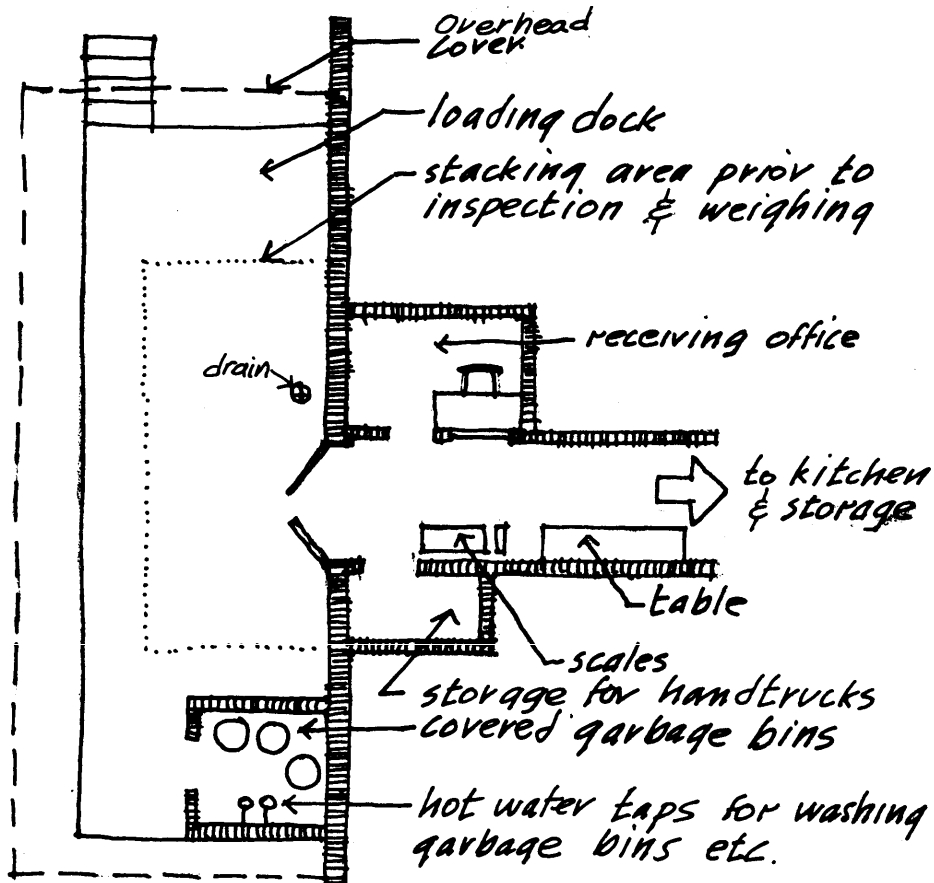

3-4.6 SUB-SPACE: STORAGE

3-4.6.1 General Considerations: A system of supply transport should be worked out in the kitchen concept stage to provide general supply and re-supply routes with appropriate aisle widths. These routes should, as far as possible:

- A. Provide dedicated transport zones.
- B. Be located parallel or perpendicular to working aisles--not on the perimeter of the space.
- C. Serve two departments at one time.
- D. Minimize crossover traffic between working areas.
- E. Use flush thresholds at door openings.

3-4.6.2 Food, Dry Storage

A. General Considerations

1. Should be protected from sweating walls, dripping pipes and subsoil dampness.
2. Should be screened against mice and vermin.
3. Orderly system should be established for cataloging location of goods and rotating stocks.
4. Work tables should be provided for rough portioning of supplies.
5. Equipment should be easily mobile, and construction materials designed for easy cleaning and draining.

B. Shelf Design and Arrangement

1. Lowest shelf should be at least 8" off floor, highest 72".
2. Adjustable shelves for spacing flexibility
3. Some shelves should be wide enough to store case boxes.
4. Bulk items (sugar, flour, potatoes, etc.) may be stored best in bulk containers

C. Environmental Considerations

1. Temperature should never be higher than 70°F. Recommended range is 40°F to 70°F.
2. Motors, compressors and other heat-producing equipment should not be located in storage areas.
3. Ventilation: Admit cool air near floor and exhaust warm air near ceiling.
4. 2" space between shelves and walls recommended, as are slatted shelves.
5. Heating pipes should be well-insulated.

4-KITCHEN

3-4.6.3 Storage, Refrigerated

A. General Considerations

1. Refrigerator and freezer should be separate spaces.
2. Freezers should be located opening onto refrigerated space.

B. Preliminary Space Allocation Guidelines

1. For preliminary planning purposes, allocate space for all food storage (dry, refrigerated, and frozen) on the following basis:

	Meals Served Per Day			
	400	800	1 200	1600
Total food storage area s.f.	400-600	600-800	850-1100	1100-1250

Within this total area allocate specific storage space as follows:

2. Meats: 15% of total refrigerated space
3. Fruits and Vegetables: 10% of total refrigerated space
4. Defrosting and Dairy: 45% of total refrigerated space
5. Freezer: 30% of total refrigerated space

C. Environmental Consideration

1. Meats: 33°F to 38°F, 80% to 85% humidity
2. Fruits and Vegetables: 33°F to 38°F
3. Defrosting and Dairy: 33°F to 38°F
4. Freezer: -10°F to 0°F

3-4.6.4 Storage, Refrigerated, of Prepared Foods

- A. Salads and Sandwiches: Salads and sandwiches may be prepared ahead of main rush periods (to minimize labor and keep a more constant work load) and stored in holding refrigerators.
- B. Carts used for storage should be sized to allow whole cart to be wheeled to holding and service area.

- C. Pass-through refrigerators used for storage should be located at end of preparation area, next to holding and service area.
- D. Meats and Vegetables: Meat and vegetable products may be pre-cooked to approximately 80% of finish and frozen to be re-cooked or re-constituted later during peak periods.
- E. Frozen and refrigerated areas should be located and designed to allow easy storage and returning of carts loaded with pre-cooked meat and vegetable products.

3-4.6.5 Storage, Other

- A. Provide closet for equipment used to clean kitchen area.
- B. Closet should be provided out of sight of patrons.
- C. Allow about 1.5 to 2 s.f. of closet area per 20 meals served.
- D. Additional supplies--extra dishes, glasses, flatware, utensils and paper goods.

3-4.6.6 Planning Considerations

- A. Kitchen storage for the smaller kitchen may be concentrated close to service entrance.
- B. In a large kitchen, storage should be located convenient to preparation areas.

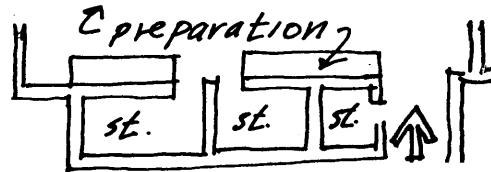

3-4.7 SUB-SPACE: PREPARATION AND PORTIONING

3-4.7.1 Meats: In this area butchers prepare meat for cooking in portion control allotments. Trend is toward buying meat already proportioned, or proportioning near the storage area, so that meats arrive at butcher's area in ready-to-cook state. See Figure 3-17.

4-KITCHEN

Figure 3-17 Relationship of Meat Preparation to Other Areas.

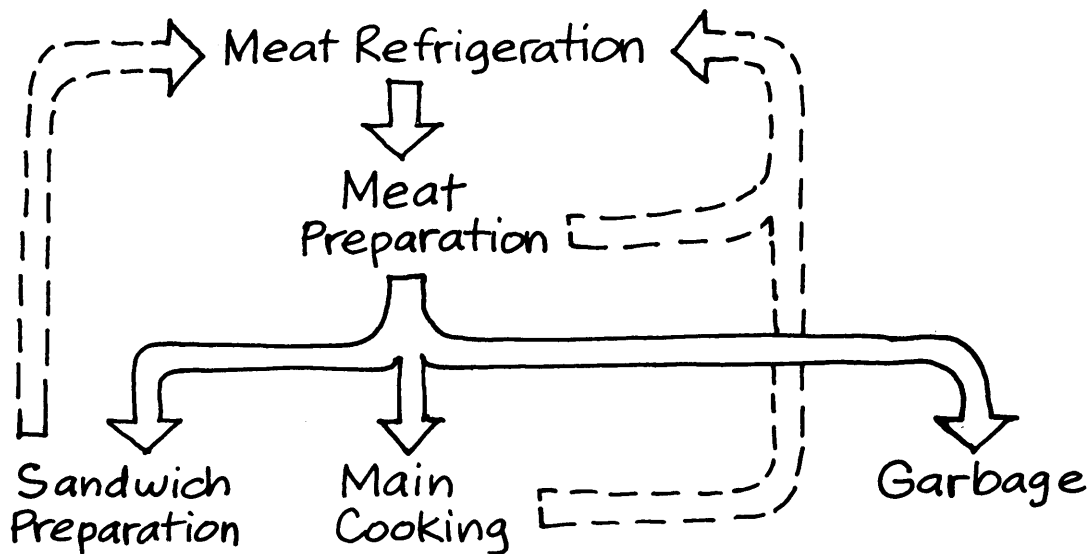

A. Required Equipment

1. Choppers and chopping block
2. Slicers
3. Sink
4. Knife rack
5. Patty molding machine
6. Work tables (portable)
7. Additional portable racks and tables
8. Grinder
9. Tenderizer
10. Fish box
11. Meat saw

B. Additional Equipment for Sandwich Preparation, if Located in the Meat Department

1. Mixers
2. Slicers
3. Bread storage
4. Tilted tray dispenser for mayonaise, etc.
5. Toasters
6. Plate dispensers
7. Double sink
8. Small storage space
9. Sandwich wrapping machine

3-4.7.2 Vegetables

- A. In this area, the fresh vegetables are prepared for cooking and salads. In many kitchens vegetables are prepared the day before their usage in the salad and main cooking areas, in which case the prepared vegetables are stored in holding refrigerators. See Figure 3-18.

Figure 3-18 Relationship of Vegetable Preparation Area to Other Areas

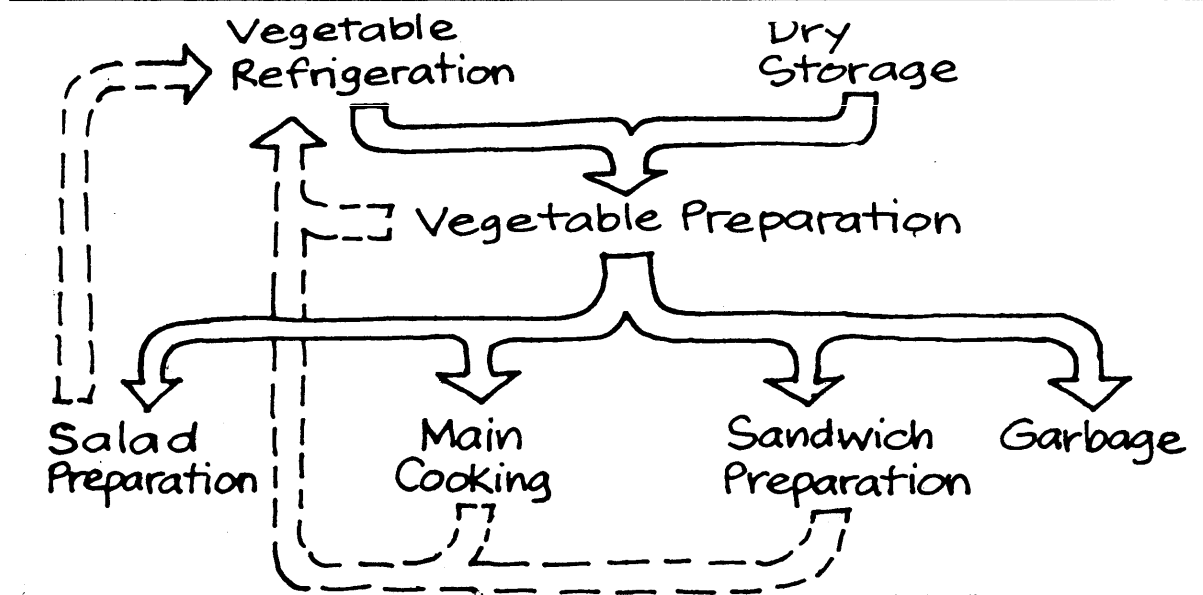

4-KITCHEN

B. Required Equipment

1. Slicers
2. Double sink with drainboard
3. Peeler
4. Reach-in refrigerator
5. Mixer
6. Cutter and dicer
7. Portable racks, cold cabinets, plate dispensers, etc.

3-4.7.3 Salads

- A. In this area the ingredients prepared in the vegetable preparation area and/or items from the fruit and vegetable refrigerator are used. Small amounts of meat and dairy products may also be used in some salads. In many cases the salad and vegetable preparation areas are combined, or are located next to each other in order to use the same equipment. See Figure 3-19.

Figure 3-19 Relationship of Salad Preparation Area to Other Areas

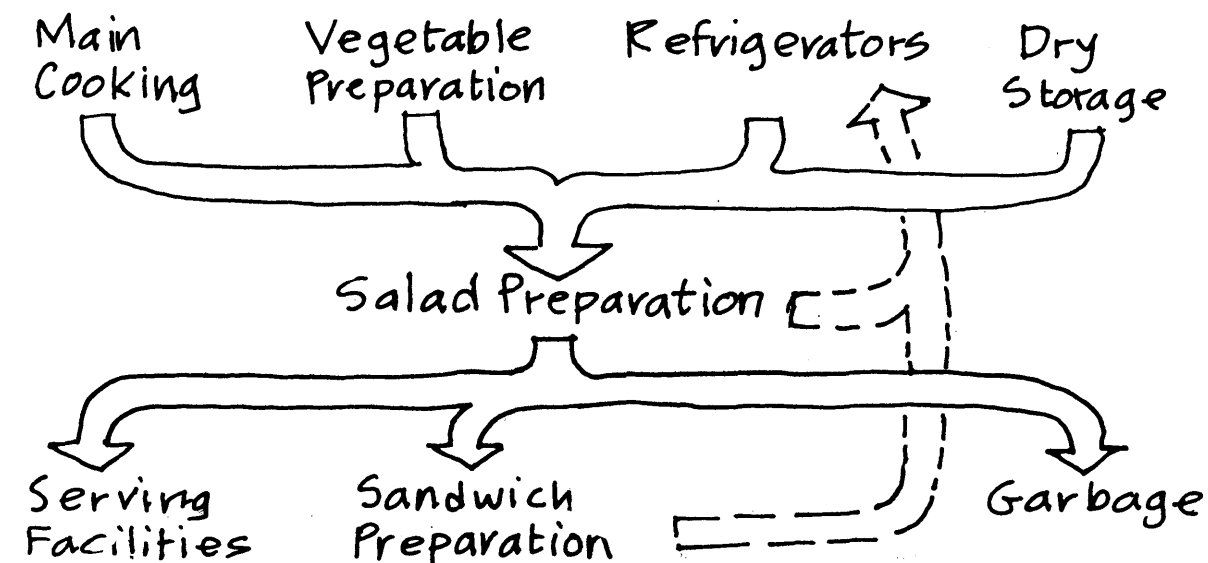

B. Required Equipment: This area works generally in combination with vegetable preparation and uses its equipment. In addition, the following may be provided:

1. Pass-through refrigerator
2. Storage refrigerator
3. Portable tray carts
4. Ice bins

3-4.8 SUB-SPACE: COOKING

3-4.8.1 General Considerations

- A. Both meat and vegetables are usually cooked in this area.
- B. In general, it has been found advisable to cook such items as vegetables in small batches, as close as possible to serving time; this requires that at least the vegetable cooking should be done as near the serving area as possible.
- C. Meats may be prepared in large batches, but the trend is towards staggering the start and finish of meat cooking, even though no equipment may be saved, meat preparation can be better related to serving demand.
- D. Fryers should have close connection with the serving areas as fried foods tend to lose their crispness after being placed in a warming or rewarming area.
- E. Drains in floor for easy cleaning and maintenance of kitchen and cooking areas.
- F. General relationships of this area to other areas are shown in Figure 3-20.
- G. Required Equipment: (Not all kitchens will have all the equipment noted.)
 1. Conventional and convection ovens
 2. Revolving-deck roast ovens
 3. Fryers (deep) - tilting
 4. Griddles

4-KITCHEN

5. Steam cookers (and steam jet cookers)
6. Trunion kettles with mixer
7. Broilers
8. Hot top range with open burners
9. Salamanders
10. Open grill
11. Fish fryers - separate
12. Cooks table with sink and drainboard
13. Small mixer
14. Cooking hoods for exhaust
15. Microwave oven
16. Pot racks
17. Mixers
18. Refrigerated drawers for undercounter storage

Figure 3-20 Relationship of Cooking Area to Other Areas

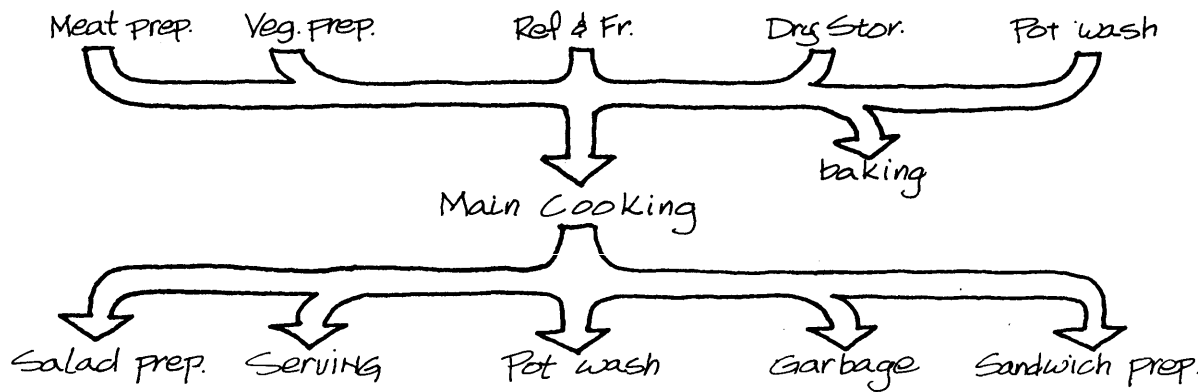

3-4.8.2 Equipment Layout Considerations

- A. The broiler should be at one end of the line--away from the traffic in front of the cooking equipment. Adequate refrigerated storage and work space should be provided for the broiler operator.

-
- B. Fryers may be located near the broiler if the same person will operate both or they may be located at the far end of the range battery. Sufficient work table space and an area to drain fried foods must be provided in addition to refrigeration and, in some cases, freezer storage space.
 - C. The steam table for serving area, if it is to be from the same area as cooking, should be near the broilers and fryers.
 - D. Space between cook's table and cooking equipment should be at a minimum, but should provide for opening of range ovens, steamers, etc.
 - E. All heat-producing equipment should be vented to an effective exhaust hood.
 - F. Sufficient space for cleaning should be provided behind equipment which is backed up to a wall.
 - G. It is preferable to provide breaks in extended cook's or serving tables for access between aisles.
 - H. As with the arrangement of the other equipment, design should minimize circulation and crossover traffic.

3-4.8.3 Baking Area

- A. General Considerations:
 - 1. Of all food preparation departments, the bakery operation is least affected by distance from the main facilities (since mobile racks and carts are used to transfer goods).
 - 2. In general, the bake shop should be located near the storage area--both dry and refrigerated--and near the pot washing facilities.
 - 3. There are two general modes of operation. "Full bake" involves baking from scratch. "Bake-off" uses frozen, pre-prepared semi-baked goods that need only thawing, possibly proofing, and finish baking. Bake-off operations are usually cheaper, particularly in small operations, in which savings can be as much as 75%. For this reason the bake-off operation is almost universally used.

4-KITCHEN

4. Baking and cooking can possibly be combined or adjacent in small operations since ovens, mixers, and steam kettles can be shared, particularly if baking is done in off-cooking hours.
 5. Mobile and pass-through storage units may be used between baking and serving sections, and for storage of some dry and refrigerated items. Unless the work centers for mixing, baking and portioning are located close to each other, they will need additional storage and refrigerated space. Refrigeration needs may be combined in smaller installations.
 6. As much clear space should be provided in front of the bake oven as the bake oven is deep--front to back.
 7. Provide baker's work table. Portable bins for flour and sugar underneath table are preferred. The baker's table, as with the proof box, should be near the ovens.
 8. Mixers (and attachments), pastry stove and steam jacketed kettle (if used) should be located near the baker's table.
- B. Required Equipment - (for average size operation making maximum use of mixes and prepared products such as pie filling)
1. Oven or ovens
 2. Mobile proofing cabinet
 3. Mobile racks for 18/26 pans
 4. Mixers, large and small
 5. Baker's table
 6. "Mobile ingredient bins
 7. Scale
 8. Baker's sink
 9. Freezer
 10. Refrigerator

-
11. Baker's store (optional)
 12. Sheeter (optional)
 13. Diver/rounder (optional)
- C. Required Equipment (for operation buying frozen, prepared foods)
1. Oven or ovens
 2. Mobile racks for 18/26 pans
 3. Freezer

3-4.9 SUB-SPACE: HOLDING AND SERVING

3-4.9.1 General Considerations: Two major zones of activity are involved in this area-- serving and waitress service.

- A. Serving: This may be performed by a separate employee whose job is to take bulk cooked foods and apportion individual orders from an order wheel (or in a cafeteria line). As this process tends to confuse circulation routes in the cook's area, a better solution is to divide the responsibilities of the cooking staff by portioning off the duties and having two or more cooks (or assistants) cooking and serving orders from the order wheel. Filled hot entree items are set on warming plates for holding until waitress pick-up. Circulation space should be adequate for several waitresses at one time (to prevent mix-ups and breakage).
- B. Equipment
1. Warming plates - typically steam tables and bain maries
 2. Cooling plates
 3. Pass-through refrigerators (mobile)

4-KITCHEN

- C. Waitress Service: Will include all “to order” small items that a waitress adds to the regular meal such as preparation of beverages, bread and butter, small desserts, salad dressing. These services are most easily dealt with if they are spread around the pick-up areas in scramble form, so that several waitresses may perform different operations all along the line.

- D. Required Equipment
 - 1. Coffee dispensers
 - 2. Tea dispensers
 - 3. Milk dispensers
 - 4. Soft drink dispensers
 - 5. Refrigeration and ice machines (mobile)
 - 6. Roll warmers
 - 7. Butter dispensers
 - 8. Wine storage area/refrigeration
 - 9. Pass-through dessert and salad refrigerators (mobile)
 - 10. Salad dressing containers
 - 11. Storage area for plates, glasses, stemware, etc.

3-4.10 SUB-SPACE: CLEAN-UP AND DISHWASHING

2-4.10.1 General Considerations

- A. Clean-up: Operation intended to clear tables and move soiled items to dishwasher area. Two basic methods of operation. In one, the waitress or busboy places soiled items directly in dishwasher or in mobile cart for transfer to dishwasher. Alternatively, the user places items on conveyor or mobile cart.

-
- B. Dishwashing: Specific dishwashing operation will vary according to the number of meals served, the degree of automation desired, the supply of utensils and desired rate of flow, and the floor space available. Early decisions made on these matters will determine the policy and specify a dishwasher able to clean dishes at just faster than soiled rate during normal operation, saving the excess soiled dishware for slack periods and keeping the dishwasher running on a full-time basis.
- C. Equipment
1. Scrapping table
 2. Dispenser (refuse bins)
 3. Compactors, food waste grinders
 4. Pre-rinse machines
 5. Conveyors
 6. Tray racks and carts
 7. Plate, glass, silver dispenser (loaders)
 8. Sink
 9. Silver burnisher
 10. Floor drain
- D. Pot Washing: Pots from main cooking, serving, baking, etc., will be loaded and washed in a different location from the dishwashing activities. A minimum of a two-compartment sink with a grease catch or skimmer between the first two compartments is recommended. In many kitchens a large storage area is required for soiled pots, since they may not be washed immediately upon arrival in the pot washing area. Extra temporary storage should also be provided for clean pots prior to rerouting them to their departments.

3-4.11 SUB-SPACE: STAFF FACILITIES

- 3-4.11.1 Chef's Office: A larger kitchen should provide an office for the chef. This should be located near the receiving area, but should also have a general view of the main kitchen area through glass walls. In a small kitchen, space should be found for a desk and filing area for the chef.

4-KITCHEN

3-4.11.2 Employee's Rest Rooms, Locker Rooms

3-4.11.3 Employee's Dining Room: When the kitchen staff exceeds 10 in number, consideration should be given to providing staff dining room. This should be located near the kitchen receiving-area and should be visible from the chef's office and the main kitchen area.

3-4.12 GENERAL ENVIRONMENTAL PERFORMANCE REQUIREMENTS

3-4.12.1 Lighting

- A. Natural: Not essential.
- B. Artificial: High intensity. Since many kitchen surfaces will be glossy, light colors, particular care is necessary to avoid glare. Fixtures should be easily maintained and cleaned; recessed ceiling fixtures are desirable. See Table 4-7 for standards.

3-4.12.2 Acoustics

- A. Sound, Generation: The kitchen is a noisy work space.
- B. Sound, Isolation: Planning requirements generally insure adequate isolation.

3-4.12.3 Thermal: Kitchen generates considerable cooking odor and heat. High standard of ventilation essential. Kitchen should be negative pressure area relative to other spaces. If kitchen is open to serving or eating areas, special care must be taken to provide adequate capacity hoods. Provide minimum of 24 air changes/hour in kitchen area.

3-4.13 RELATIONSHIPS TO OTHER SPACES: See Figures 3-21 and 3-22.

Figure 3-21 Affinity Matrix for Kitchen

The affinity matrix indicates relationships between space 4 - Kitchen and other generic spaces as being required, or desirable (+), of no consequence (0), or undesirable (-).

	1 - Entry	2 - Dining Room	3 - Bar	5 - Multi-use	6 - Party Room	7 - Rec. Room (Q)	8 - Rec. Room (N)	9 - Administration	10 - Rest Rooms	11 - Storage	12 - Maintenance	13 - Mechanical	14 - Lockers
4 - Kitchen	+	+	0	+	+	+	+	+	0	0	0	0	+

4-KITCHEN

Figure 3-22 Relationship of Kitchen to Other Areas

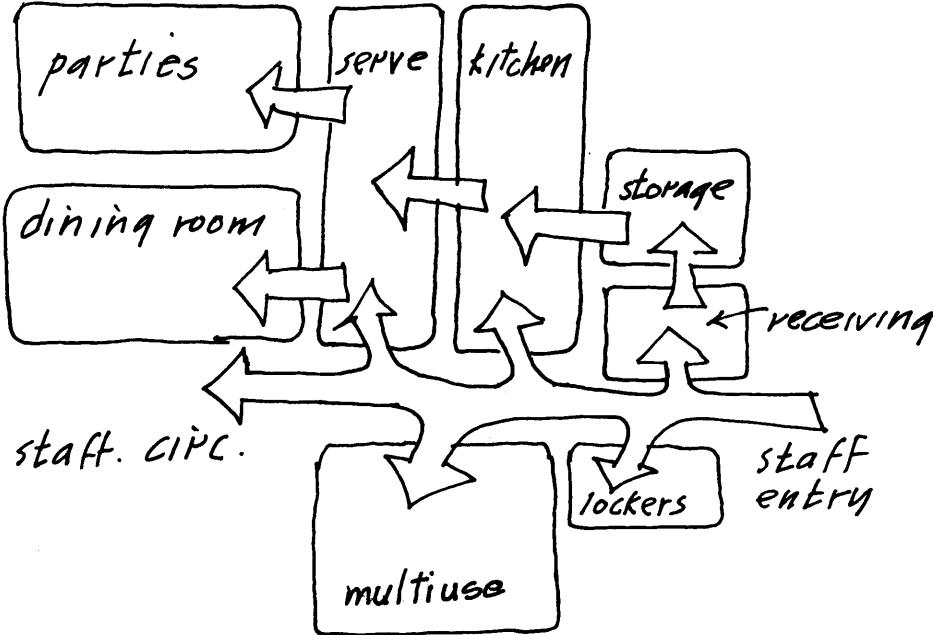

3-5.1 ACTIVITIES AND USES ANTICIPATED: Dances, large receptions, bingo games, live music. In a small club the multi-use room may also have to be used as the dining room or bar. This is undesirable since setting up for ballroom activities will 'inevitably interfere with dining requirements. A large room may be divided into two or more smaller meeting areas to improve utilization. The multi-use room is used predominantly at night, although it may be used for receptions during the day, particularly at lunch time. It is necessary to provide food and bar service to this space.

3-5.2 CHARACTER OF SPACE: The multi-use room should appear as spacious and dignified as funds will permit. A traditional atmosphere is usually preferred.

3-5.3 DIMENSIONAL CHARACTERISTICS

3-5.3.1 Governing Dimensions

- A. Horizontal Dimensions: Maximum aspect ratio: 2:1
- B. Vertical Dimensions: Minimum ceiling height: 10'-0", for room up to 30'-0" wide. Increase minimum ceiling height by the approximate ratio of 1'-0" for each increase of 5'-0" in room width.

3-5.3.2 Sizing of Spaces

- A. Sizes of multi-use room may vary depending on local taste and management policy. In addition, its size is affected by extent to which separate party rooms are provided, rather than subdividing multi-use room for parties.
- B. Guidelines for Establishing Area of Multi-use Room: Multi-use room plus party rooms = 20-25% gross area. Critical sizing activity: Bingo. Allow 15 s.f./person (see Figure 3-23) . Allow 13 s.f./seat for banquets.

3-5.4 BASIC EQUIPMENT REQUIRED

3-5.4.1 The dance floor should have a hardwood surface; the remainder of the area should have a high quality carpet.

3-5.4.2 Dance activities require tables and chairs around the perimeter of the room, for sitting out and socializing.

3-5.4.3 Bingo requires a seat at a table for every participant; additional space may be needed for the display of prizes.

5-MULTI-USE

3-5.4.4 A stage area is necessary for performers. The stage should be raised not less than two feet above the general floor level. For maximum flexibility a sectional, portable stage is satisfactory.

3-5.4.5 A good sound system is essential, suitable both for speech and music.

3-5.4.6 The wide variety of furnishing requirements requires storage space which must be directly accessible to the multi-use room. Provide a minimum of 1 s.f. of table and chair storage per person, based on 13 s.f./person overall occupancy.

3-5.4.7 If movable walls are used, they should be of high quality and readily movable; electrical operation of large walls is desirable.

Figure 3-23 Planning Dimensions of Layout for Bingo

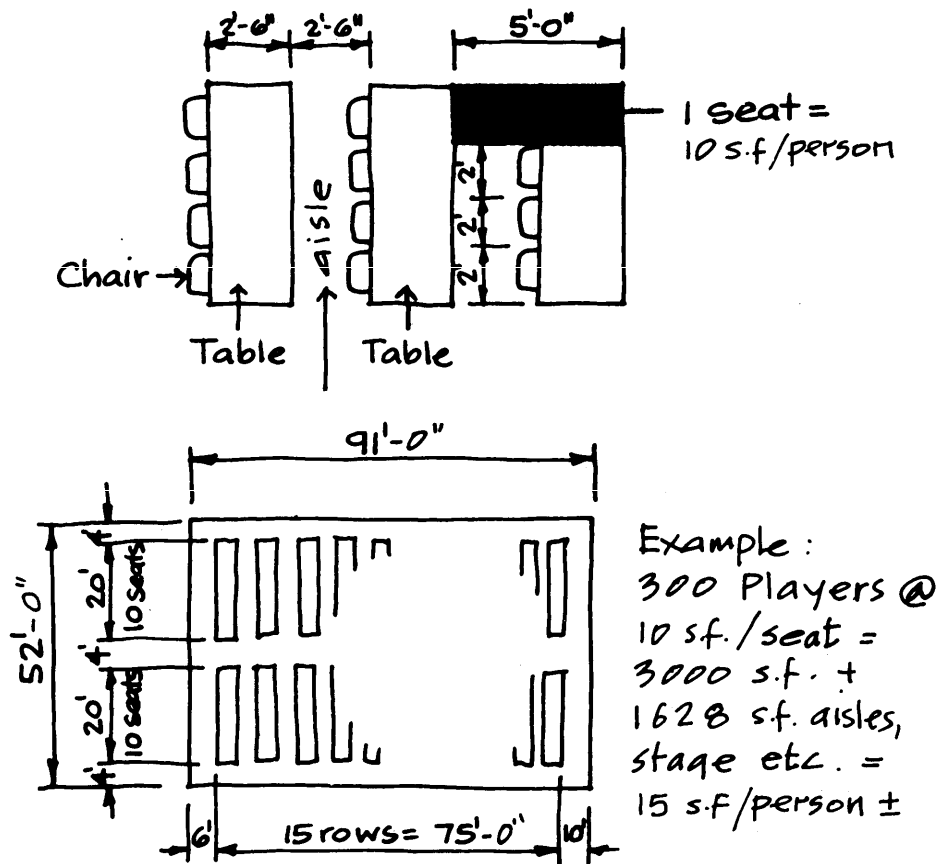

3-5.5 REQUIREMENTS OF SUB-SPACES WITHIN MAIN SPACE: Dressing Rooms: A large multi-use room should provide separate dressing rooms for male and female performers. These should have direct access to a separate entrance, or to the staff area of the facility. Ready access to rest rooms is essential. Dressing rooms should have a dressing table, chairs and a sink; full length mirrors are necessary as are provisions for hanging clothes.

3-5.6 PLANNING CRITERIA

3-5.6.1 It should be possible to enter the multi-use room directly from the main entrance, without passing through other activity spaces.

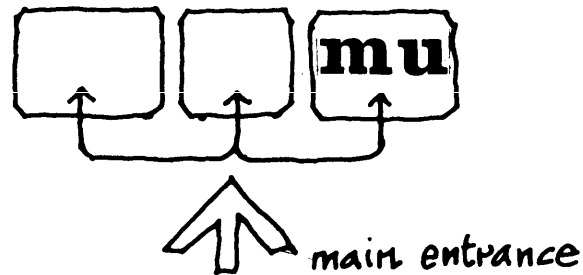

3-5.6.2 It is desirable for the multi-use room in a large club to have a separate entrance.

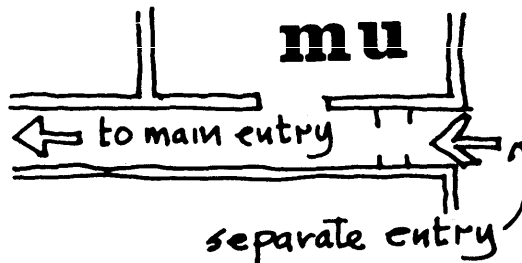

3-5.6.3 Provide service bar with direct access to multi-use room, but not facing directly onto multi-use space.

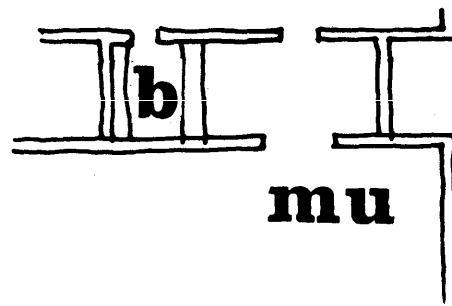

5-MULTI-USE

3-5.6.4 Performers should be able to reach stage and dressing rooms by entry separate from public areas.

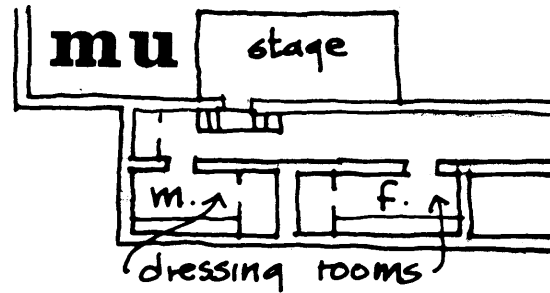

3-5.6.5 Provide access to rest rooms adjoining entry to multi-use room.

3-5.6.6 In smaller club, rest rooms for multi-use room, dining room, bars and entry may be common.

3-5.6.7 If surroundings and climate are appropriate, provide outside terrace associated with multi-use room.

3-5.6.8 Space should be column-free.

3-5.6.9 Provide storage for tables and chairs directly accessible from the main room.

3-5.6.10 Provide direct access to serving area of kitchen.

3-5.6.11 The best shape for an assembly or multi-use room is approximately square.

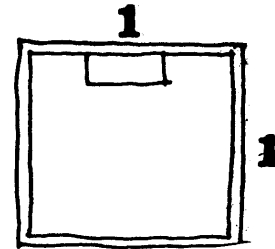

3-5.6.12 The limit of rectangularity is an aspect ratio of 2:1. Beyond this, the audience is unacceptably far from stage activities.

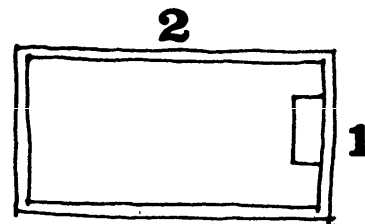

3-5.6.13 If room is to be subdivided, a ratio of about 1-1/2:1 is good, giving two well-proportioned rooms with ratio of 1-1/3:1.

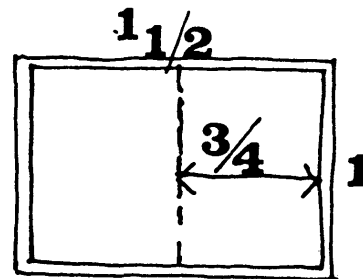

3-5.6.14 For subdividing room into 3, use approximately a ratio of 2:1 subdivided into 3 rooms with good ratio of 1:1-1/2 or into two rooms with ratios of 1:1-1/2 and 1:1-1/3.

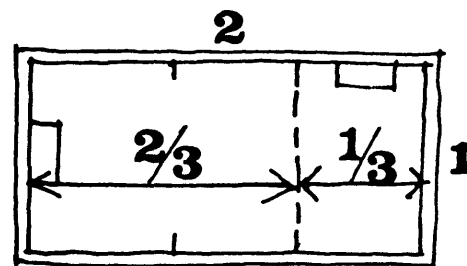
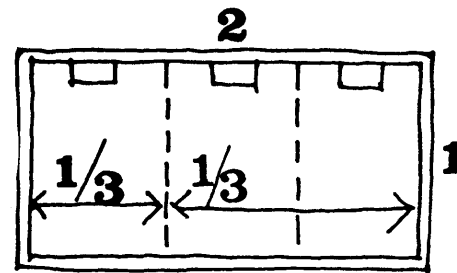

3-5.7 GENERAL ENVIRONMENTAL PERFORMANCE REQUIREMENTS

3-5.7.1 Lighting

A. Natural

1. Since most use of the multi-use room is at night, natural lighting is not necessary.
2. If there is an attractive view, the multi-use room may open out onto a terrace, deck, or court.

B. Artificial

1. Lighting should be attractively designed, and lighting levels range from fairly high for use during bingo games to low for dances. See Table 4-7 for standards.
2. Specialized stage lighting should be provided for performances.
3. Lighting atmosphere for dances should be provided a soft rather than a functional atmosphere. This requirement is best met by the use of incandescent fixtures.

5-MULTI-USE

3-5.7.2 Acoustics

- A. Sound, Generation: Bingo and live music for dances generate significant sound levels. Acoustic quality of the space should be live, but with good definition for voice and music.
- B. Sound, Isolation: The multi-use room will tend to generate more noise than surrounding spaces, with the possible exception of a bar or games room; sound isolation not critical.

3-5.7.3 Thermal: At times, such as bingo games, considerable smoke and heat may be generated by the occupants. A ventilation system that can accommodate this peak condition is essential. For moderate occupancy with no smoking, provide 5 to 8 air changes/hour. For full occupancy with smoking, system should be capable of providing 15 to 20 air changes/hour.

3-5.8 RELATIONSHIPS TO OTHER SPACES: See Figures 3-24, 3-10 and 3-13.

Figure 3-24 Affinity Matrix for Multi-use

The affinity matrix indicates relationships between space 5 - Multi-use and other generic spaces as being required or desirable (+), of no consequence (0), or undesirable (-).

	1 - Entry	2 - Dining Room	3 - Bar	4 - Kitchen	6 - Party Room	7 - Rec. Room (Q)	8 - Rec. Room (N)	9 - Administration	10 - Rest Rooms	11 - Storage	12 - Maintenance	13 - Mechanical	14 - Lockers
5 - Multi-use	+	0	+	+	0	-	-	-	-	+	-	-	0

3-6 PARTY ROOM

3-6.1 ACTIVITIES AND USES ANTICIPATED: Private parties, receptions, and club activities. Meetings will be associated almost invariably with cocktail and meal service.

3-6.2 CHARACTER OF SPACE: Party rooms should be attractive and dignified. A traditional atmosphere is desirable. Extensive use of movable walls may result in an impersonal atmosphere and limit the opportunities for decoration. If a number of party rooms are provided, there should be some variety in character achieved through use of color, light and texture.

3-6.3 DIMENSIONAL CHARACTERISTICS

3-6.3.1 Governing Dimensions: See requirements of generic space 2 - Dining Rooms.

3-6.3.2 Sizing of Spaces: See requirements of generic space 5 - Multi-use.

3-6.4 BASIC EQUIPMENT REQUIRED

3-6.4.1 Provision for food and cocktail service.

3-6.4.2 Built-in service bar that can be kept stocked and locked at all times.

3-6.4.3 Carpet for flooring.

3-6.4.3 Coat racks.

3-6.5 REQUIREMENTS OF SUB-AREAS WITHIN MAIN SPACE: Not applicable.

3-6.6 PLANNING CRITERIA

3-6.6.1 Provide direct access to serving area of kitchen.

3-6.6.2 Party rooms created by subdividing a larger space with movable walls should each have independent access and egress. (See Figure 3-26)

3-6.6.3 Provide direct access to storage for tables and chairs.

3-6.6.4 Provide party room service bars (preferred), service access to main bar, or sufficient space to set up a mobile or temporary bar (least desirable).

3-6.6.5 Party rooms created by movable walls should be of different sizes, to provide the greatest variety of alternative sizes. (See page 3-42)

6-PARTY ROOM

3-6.6.6 Party rooms can provide useful expansion space for dining or multi-use rooms.

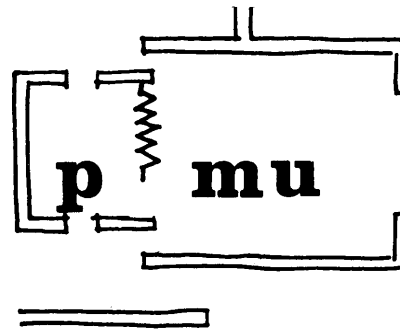

3-6.7 GENERAL ENVIRONMENTAL PERFORMANCE REQUIREMENTS

3-6.7.1 Lighting

- A. Natural: Natural lighting is not essential, but an attractive view may be exploited.
- B. Artificial: Incandescent lighting is desirable, with provision for dimming. See Table 4-7 for standards.

3-6.7.2 Acoustics

- A. Sound, Generation: The party room may be relatively noisy.
- B. Sound, Isolation: The party room should be isolated against adjoining areas, for some activities may be quiet, and not wish to be disturbed by adjacent noise. Adjoining party rooms should be isolated from each other.

3-6.7.3 Thermal: Occupants may generate considerable smoke and heat. An effective ventilation system is essential. System should be capable of providing 15 to 20 air changes/hour.

Figure 3-25 Affinity Matrix for Party Room

The affinity matrix indicates relationships between space 6 - Party Room and other generic spaces as being required or desirable (+), of no consequence (0), or undesirable (-).

	1 - Entry	2 - Dining Room	3 - Bar	4 - Kitchen	5 - Multi-use	7 - Rec. Room (Q)	8 - Rec. Room (N)	9 - Administration	10 - Rest Rooms	11 - Storage	12 - Maintenance	13 - Mechanical	14 - Lockers
6 - Party Room	0	0	+	+	0	-	-	-	-	0	-	-	0

6-PARTY ROOM

Figure 3-26 Relationship of Party Room to Other Spaces

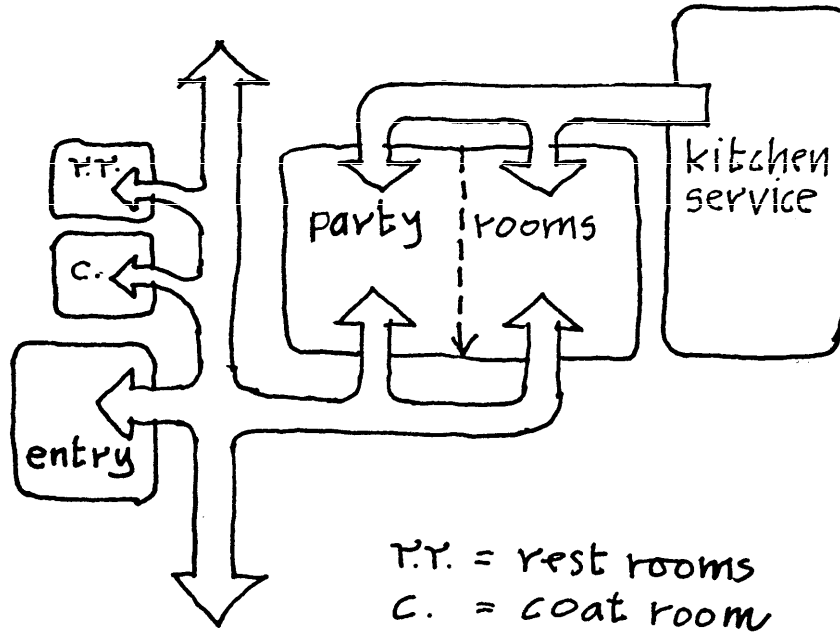

3-7 QUIET RECREATION

3-7.1 ACTIVITIES AND USES ANTICIPATED: Reading, watching T.V., quiet socializing, quiet games, such as bridge. May be used at all hours of the day or night. Predominantly used by single people and small groups.

3-7.2 CHARACTER OF SPACE: The space should have a quiet atmosphere, with soft furnishings creating areas of privacy.

3-7.3 DIMENSIONAL CHARACTERISTICS

3-7.3.1 Governing Dimensions

- A. Horizontal Dimensions: Maximum aspect ratio: 2:1.
- B. Vertical Dimensions: 8'-0" for room 10'-0"+ wide.
Minimum ceiling height should increase by the approximate ratio of 1'-0" for each increase of 5'-0" in room width.

3-7.3.2 Sizing of Spaces: Requirements for this space, and size, may vary depending on local requirements and operational policies.

Min. area of space: 200 s.f.
Max. area of single space: 1000 s.f.
Allow 3-5% of gross floor area for this space.

3-7.4 BASIC EQUIPMENT REQUIRED: Comfortable furniture; low tables; card tables; carpeted; T.V. room requires outlets, and T.V. outlets to antenna.

3-7.5 REQUIREMENTS OF SUB-AREAS WITHIN MAIN SPACE: Not applicable.

3-7.6 PLANNING CRITERIA

3-7.6.1 Should be accessible from main entry without passing through other activity spaces.

3-7.6.2 Access to food and beverage service not required.

3-7.6.3 Should be planned as dead-end space, to obviate through traffic.

3-4.6.4 T.V. viewing must be provided in space acoustically isolated from other quiet recreation activities.

3-7.7 GENERAL ENVIRONMENTAL PERFORMANCE REQUIREMENTS

3-7.7.1 Lighting

- A. Natural: Not essential. Undesirable in T.V. room area.
- B. Artificial: Lounge and reading areas should have soft lighting of a residential nature. T.V. rooms should have a low light level. See Table 4-7 for standards.

7- QUIET RECREATION

3-7.7.2 Acoustics

- A. Sound, Generation: This is a quiet space, with minimal sound generation. However, if T.V. is provided, considerable sound may be generated.
- B. Sound Isolation: These spaces should be acoustically isolated.

3-1.7.3 Thermal: Typically, these spaces will have a low occupancy and will generate little heat or smoke. Spaces should be comfortable when only a small number of people are present. Provide 5 to 8 air changes/hour.

3-7.8 RELATIONSHIPS TO OTHER SPACES: See Figures 3-27 and 3-28.

Figure 3-27 Affinity Matrix for Quiet Recreation

The affinity matrix indicates relationships between space 7 - Rec. Room (Q) and other generic spaces as being required or desirable (+), of no consequence (0), or undesirable (-).

	1 - Entry	2 - Dining Room	3 - Bar	4 - Kitchen	5 - Multi-use	6 - Party Room	8 - Rec. Room (N)	9 - Administration	10 - Rest Rooms	11 - Storage	12 - Maintenance	13 - Mechanical	14 - Lockers
7 - Rec. Room (Q)	-	-	-	-	-	-	-	-	-	0	-	-	0

Figure 3-28 Relationship of Quiet Recreation Room to Other Spaces

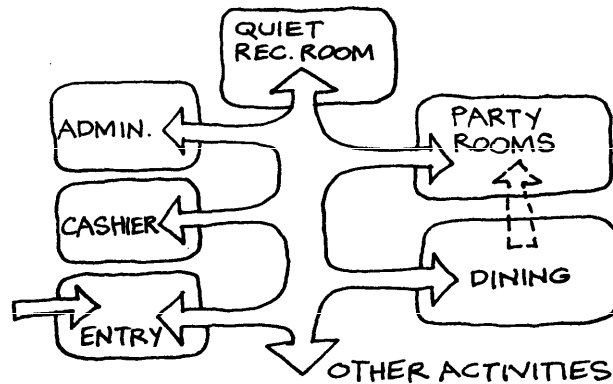

3-8.1 ACTIVITIES AND USES ANTICIPATED: Pool playing, use of game machines. Female guests may be invited, but users are predominantly male.

3-8.2 CHARACTER OF SPACE: An informal, masculine space, analogous in atmosphere to pool room.

3-8.3 DIMENSIONAL CHARACTERISTICS: See requirements for generic space Recreation Room, quiet.

3-8.4 BASIC EQUIPMENT REQUIRED

3-8.4.1 Games and equipment provide the main furnishing.

3-8.4.2 Numbers and types of games may fluctuate considerably, based on availability and popularity.

3-8.4.3 Provide frequent electrical outlets, or continuous plug-in conductor at baseboard.

3-8.5 REQUIREMENTS OF SUB-AREAS WITHIN MAIN SPACE: Not applicable.

3-8.6 PLANNING CRITERIA

3-8.6.1 Should be directly accessible from main or secondary entrance, or from informal bar. In small club, may be part of bar.

3-8.6.2 Should be isolated in location from quiet spaces.

3-8.6.3 An ideal arrangement is to group together an informal entry, bar and game room.

3-8.7 GENERAL ENVIRONMENTAL PERFORMANCE REQUIREMENTS

3-8.7.1 Lighting

- A. Natural : Natural lighting is not essential.
- B. Artificial: Fairly high intensity fluorescent lighting is appropriate. See Table 4-7 for standards.

3-8.7.2 Acoustics

- A. Sound, Generation: Some amusement machines are very noisy; in addition, they generate excitement which results in vocal noise.
- B. Sound, Isolation: This space should be isolated from others.

8 - NOISY RECREATION

3-8.7.3 Thermal: May generate considerable smoke and heat, however, this is a specialized space, and a slightly warm smoky atmosphere may not be undesirable. Provide 12 to 15 air changes/hour.

3-8.8 RELATIONSHIPS TO OTHER SPACES: See Figures 3-29 and 3-30.

Figure 3-29 Affinity Matrix for Noisy Recreation

The affinity matrix indicates relationships between space 8 - Rec. Room (N) and other generic spaces as being required or desirable (+), of no consequence (0), or undesirable (-).

	1 - Entry	2 - Dining Room	3 - Bar	4 - Kitchen	5 - Multi-use	6 - Party Room	7 - Rec. Room (Q)	9 - Administration	10 - Rest Rooms	11 - Storage	12 - Maintenance	13 - Mechanical	14 - Lockers
8 - Rec. Room (N)	+	+	0	-	-	-	+	0	-	0	-	+	+

Figure 3-30 Relationship of Noisy Recreation Room to Other Spaces

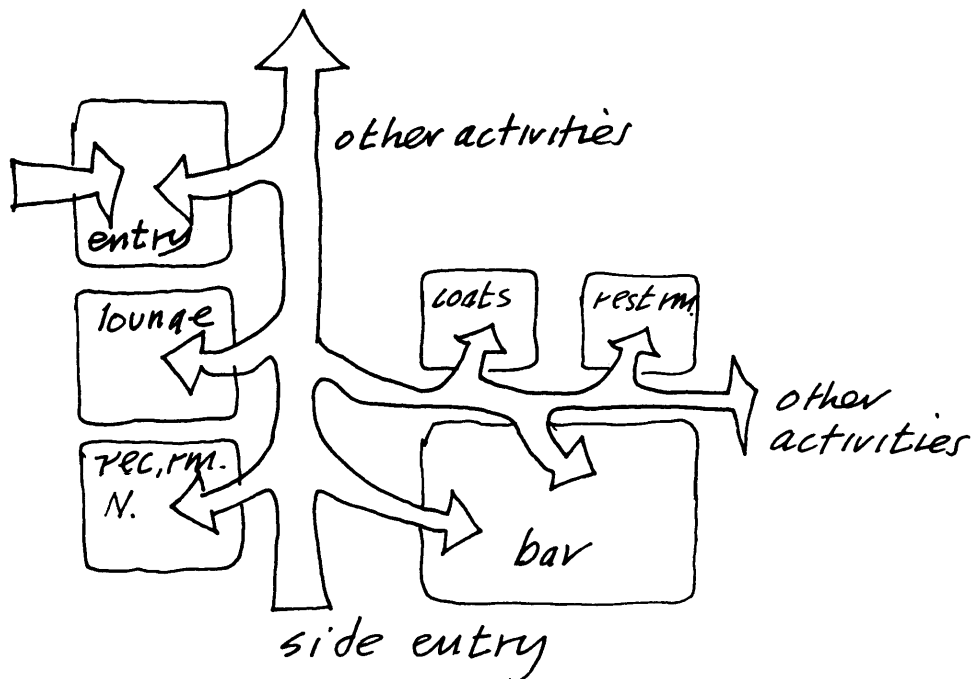

3-9 ADMINISTRATIVE

3-9.1 ACTIVITIES AND USES ANTICIPATED: Space for the administrative offices of the facility. Activities include general office administration, accountancy, reproduction, and general secretarial activities. Cashier's office will have a public window through which transactions such as dues paying are handled.

3-9.2 CHARACTER OF SPACE: Space should reflect functionalism and efficiency, but should also be fresh and attractive. Bureaucratic atmosphere should be avoided.

3-9.3 DIMENSIONAL CHARACTERISTICS

3-9.3.1 Governing Dimensions

- A. Horizontal Dimensions: Governed by requirements of furniture location and relationship, together with staff and visitor circulation space. See Figure 3-31 for basic requirements.
- B. Vertical Dimensions: No specific requirements.

3-9.3.2 Sizing of Spaces

- A. Allow: 0%-2% of gross area up to gross area of 10,000 s.f.
3%-5% of gross area up to gross area of 30,000 s.f.
2%-4% of gross area. for gross area over 30,000 s.f.
- B. Min. single occupant office size: 100 s.f.
- C. Min. single occupant plus secretary office size: 200 s.f.

3-9.4 BASIC EQUIPMENT REQUIRED: Office furniture: Desks, typing tables, filing cabinets, shelves.

3-9.5 REQUIREMENTS OF SUB-SPACES WITHIN MAIN SPACE: Not applicable.

3-9.6 PLANNING CRITERIA

3-9.6.1 In small club, administration should adjoin entrance, and cashier can act as receptionist.

3-9.6.2 In large club, administration should be accessible to, but not adjoining, main entry.

3-9.6.3 Public entry to manager's office should be through secretarial offices.

9-ADMINISTRATION

Figure 3-31 Planning Dimensions for Layout of Office Spaces

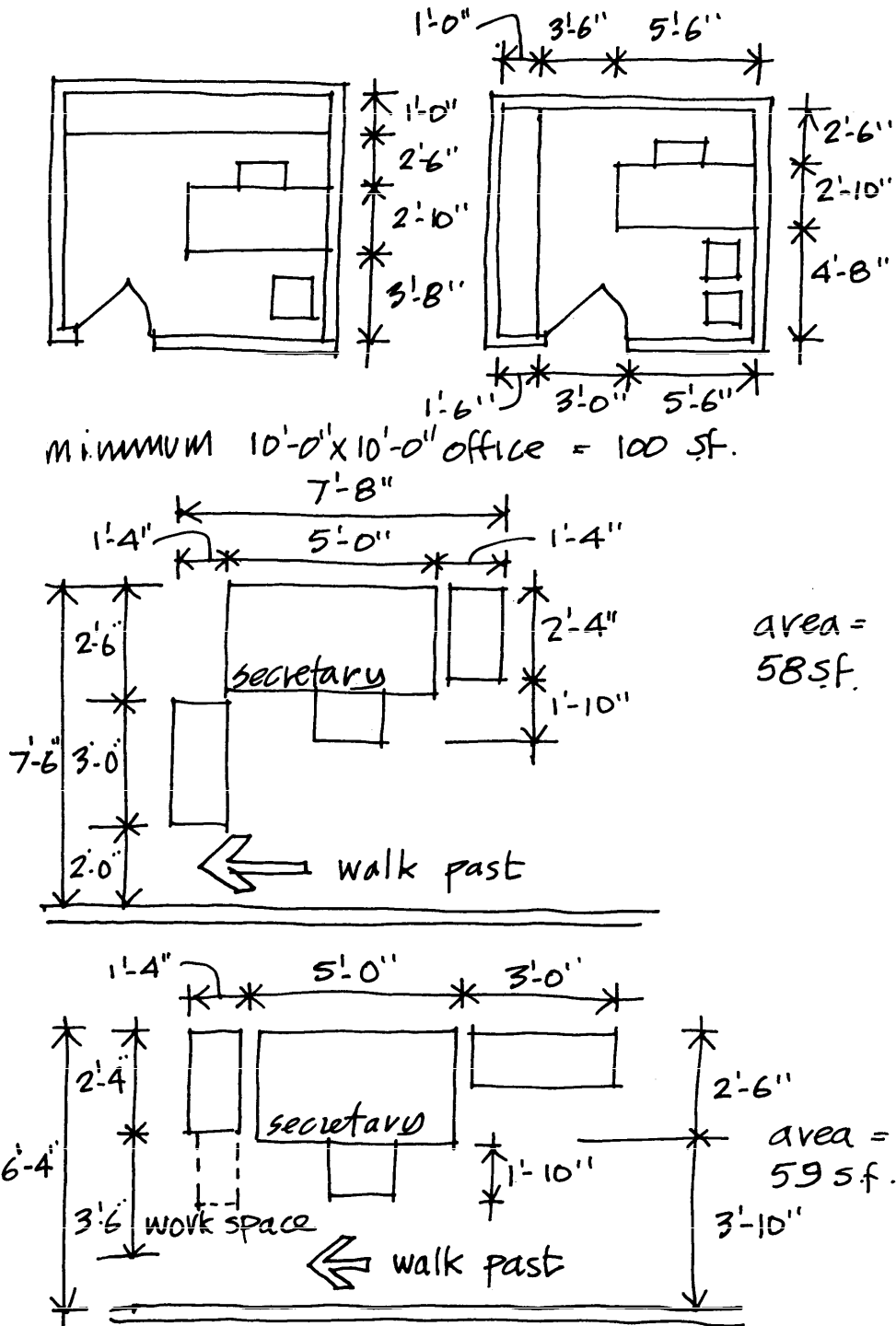

3-9.6.4 Reproduction area should adjoin secretarial area, and be acoustically isolated from it.

3-9.6.5 Cashier's office should have public window directly adjoining public hallway or entry, with waiting space.

3-9.7 GENERAL ENVIRONMENTAL PERFORMANCE REQUIREMENTS

3-9.7.1 Lighting

- A. Natural: Offices where people spend the major part of their time should have windows. Not necessary for reproduction room or cashier's office.
- B. Artificial: Efficient low brightness lighting is necessary. Fluorescent lighting is appropriate. See Table 4-7 for standards.

3-9.7.2 Acoustics

- A. Sound, Generation: Reproduction room may generate considerable noise.
- B. Sound, Isolation: Other offices should be isolated from the reproduction area.

3-9.7.3 Thermal: Low occupancy spaces. Good comfort conditions should be provided with provision for individual control. Female occupants having sedentary occupations and light clothing tend to feel cold and drafts more than males. Provide 5 to 12 air changes/hour.

3-9.8 RELATIONSHIPS TO OTHER SPACES: See Figures 3-4 and 3-5 for Entry and Figure 3-32.

9-ADMINISTRATION

Figure 3-32 Affinity Matrix for Administration

The affinity matrix indicates relationships between space 9 - Administration and other generic spaces as being required or desirable (+), of no consequence (0), or undesirable (-).

	1 - Entry	2 - Dining Room	3 - Bar	4 - Kitchen	5 - Multi-use	6 - Party Room	7 - Rec. Room (Q)	8 - Rec. Room (N)	10 - Rest Rooms	11 - Storage	12 - Maintenance	13 - Mechanical	14 - Lockers
9 - Administration	+						0		0	0	0	0	0

3-10 REST ROOMS

3-10.1 ACTIVITIES AND USES ANTICIPATED: Rest rooms for club users and staff. Womens rest room should include rest and dressing table area for make-up and grooming.

3-10.2 CHARACTER OF SPACE: Clean, functional, and well-finished. Good colors and materials in a rest room are a relatively inexpensive way of providing an atmosphere of opulence and luxury.

3-10.3 DIMENSIONAL CHARACTERISTICS

3-10.3.1 Governing Dimensions

- A. Horizontal Dimensions: Governed by requirements of privacy, fixture location and clearances, and user access.
- B. Vertical Dimensions: Minimum ceiling height: 8'-0"

3-10.3.2 Sizing of Spaces

- A. Minimum fixture requirements determined by DOD 4270.1-M. Adequate rest room facilities will utilize 3%-4% of gross floor area.

3-10.4 BASIC EQUIPMENT REQUIRED

3-10.4.1 Plumbing fixtures, counters and dressing tables as appropriate to size and function.

3-10.4.2 Fixtures should be designed and detailed with extreme attention to maintenance characteristics.

3-10.4.3 Wall hung toilet bowls and urinals should be used.

3-10.4.4 Ceiling and wall hung toilet room dividers are desirable.

3-10.4.5 Floors should be good quality ceramic tile with cove base.

3-10.5 REQUIREMENTS OF SUB-AREAS WITHIN MAIN SPACE: Not applicable.

3-10.6 PLANNING CRITERIA

3-10.6.1 Entry should be carefully screened from passers by.

3-10.6.2 Janitor's closet can be economically planned between male and female rest rooms.

10-RESTROOMS

3-10.7 GENERAL ENVIRONMENTAL PERFORMANCE REQUIREMENTS

3-10.7.1 Lighting

- A. Natural: Natural lighting not essential.
- B. Artificial: Lighting fixtures should be carefully chosen and placed to avoid an atmosphere of gloom and to accentuate cleanliness. Incandescent lighting is desirable at mirrors and dressing areas. See Table 4-7 for standards.

3-10.7.2 Acoustics

- A. Sound, Generation: Plumbing fixtures may generate sound, and should be insulated from other public areas.
- B. Sound, Isolation: Planning requirements automatically result in a high degree of isolation in this area.

3-10.7.3 Thermal: High standard of ventilation is necessary for odor control. Provide minimum of 12 air changes/hour.

3-10.8 RELATIONSHIPS TO OTHER SPACES: See figure 3-33.

Figure 3-33 Affinity Matrix for Rest Rooms

The affinity matrix indicates relationships between space 10 - Rest Rooms and other generic spaces as being required or desirable (+), of no consequence (0), or undesirable (-).

	1 - Entry	2 - Dining Room	3 - Bar	4 - Kitchen	5 - Multi-use	6 - Party Room	7 - Rec. Room (Q)	8 - Rec. Room (N)	9 - Administration	11 - Storage	12 - Maintenance	13 - Mechanical	14 - Lockers
10 - Rest Rooms	+	-	0	0	-	-	-	0	0	0	0	0	0

3-11.1 ACTIVITIES AND USES ANTICIPATED: Storage for tables, and chairs. Specialized storage for kitchen supplies, garbage, etc., is described in Section 3-4, Kitchen.

3-11.2 CHARACTER OF SPACE: Clean, functional, easy to maintain.

3-11.3 DIMENSIONAL CHARACTERISTICS:

3-11.3.1 Governing Dimensions

A. Horizontal Dimensions: No specific requirements.

B. Vertical Dimensions: No specific requirements.

3-11.3.2 Sizing of Spaces: Provide minimum of 2% of gross floor area. Provide minimum of 1 s.f. of table and chair storage per person for ballroom based on 13 s.f./per occupancy.

3-11.4 BASIC EQUIPMENT REQUIRED: Storage, shelving, and equipment appropriate to items being stored.

3-11.5 REQUIREMENTS OF SUB-AREAS WITHIN MAIN SPACE: Not applicable.

3-11.6 PLANNING CRITERIA

3-11.6.1 Locate storage areas close to point of use.

3-11.6.2 Provide access appropriate to items being stored.

3-11.7 GENERAL ENVIRONMENTAL PERFORMANCE REQUIREMENTS

3-11.7.1 Lighting

A. Natural: Undesirable, since windows provide an opportunity for break-in.

B. Artificial: No specific requirement.

3-11.7.2 Acoustics

A. Sound, Generation: Minimal.

B. Sound, Isolation: Not necessary.

3-11.7.3 Thermal: Storage should have minimal ventilation.

3-11.8 RELATIONSHIPS TO OTHER SPACES: Storage should be located as close as possible to point of use. See Figure 3-34.

11-STORAGE

Figure 3-34 Affinity Matrix for Storage

The affinity matrix indicates relationships between space 11 - Storage and other generic spaces as being required or desirable (+), of no consequence (0), or undesirable (-).

	1 - Entry	2 - Dining Room	3 - Bar	4 - Kitchen	5 - Multi-use	6 - Party Room	7 - Rec. Room (Q)	8 - Rec. Room (N)	9 - Administration	10 - Rest Rooms	12 - Maintenance	13 - Mechanical	14 - Lockers
11 - Storage	0	+	+	0	+	0	0	0	0	0	0	0	0

3-12 MAINTENANCE

3-12.1 ACTIVITIES AND USES ANTICIPATED: Space used by maintenance staff includes shop areas for maintenance and repair of movable equipment and building components, also Janitor's closets for use by personnel cleaning use spaces.

3-12.2 CHARACTER OF SPACE: Clean, functional, easily maintained.

3-12.3 DIMENSIONAL CHARACTERISTICS

3-12.3.1 Governing Dimensions

A. Horizontal Dimensions

1. Dimensions for janitor's closet: 4'-0" x 3'-0", sufficient for janitor's sink and mop storage.
2. Shop area dimensions governed by equipment in use, work space required, and material and equipment storage.

B. Vertical Dimensions

1. Janitor's closet: 7'-6" minimum
2. Shop area: 10'-0" minimum

3-12.3.2 Sizing of Spaces: Allow between 0.1-0.3% of gross floor area.

3-12.4 BASIC EQUIPMENT REQUIRED

3-12.4.1 Janitor's closet requires janitor's sink, drainboard, area for mops, shelving for cleaning supplies.

3-12.4.2 Floor drain is desirable.

3-12.4.3 Shop area, repair and maintenance equipment as appropriate for function.

3-12.4.4 Concrete floor.

3-12.5 REQUIREMENTS OF SUB-AREAS WITHIN MAIN SPACE: Not applicable.

3-12.6 PLANNING CRITERIA

3-12.6.1 Janitor's closets should be dispersed through facility.

3-12.6.2 Locate janitor's closets in hallways, close to main activity spaces.

12-MAINTENANCE

3-12.6.3 Janitor's closets are economically located between male and female rest rooms.

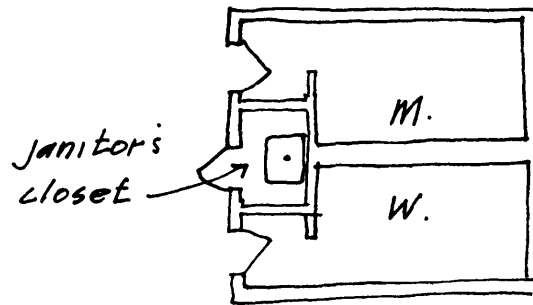

3-12.6.4 Door to Janitor's closet should open outwards.

3-12.6.5 Locate maintenance shop close to receiving area of facility.

3-12.6.6 Provide adequate access to shop for large pieces of equipment such as mobile bars, kitchen carts, etc. Direct outside access is desirable.

3-12.7 GENERAL ENVIRONMENTAL PERFORMANCE REQUIREMENTS

3-12.7.1 Lighting

- A. Natural: Not necessary in closet areas, desirable in shop areas, but not essential.
- B. Artificial: Janitor's closet, minimal illumination; shop areas, industrial type high intensity lighting at task areas, low general illumination.

3-12.7.2 Acoustics

- A. Sound, Generation: In closet areas, minimal, shop area may be considerable with use of power equipment.
- B. Sound, Isolation: Shop area should be isolated in service area of facility.

3-12.7.3 Thermal: Janitor's closet should be ventilated, shop area heated and ventilated. Special exhaust systems for sawdust, etc., as appropriate.

3-12.8 RELATIONSHIPS TO OTHER SPACES

3-12.8.1 Janitor's closets should be dispersed along circulation areas of facility in association with spaces to be maintained.

3-12.8.2 Maintenance shop is best located adjoining staff entrance and receiving area.

3-13 MECHANICAL

3-13.1 ACTIVITIES AND USES ANTICIPATED: Space for the location of mechanical equipment. Access only by qualified persons for inspection, repair, and maintenance.

3-13.2 CHARACTER OF SPACE: Functional

3-13.3 DIMENSIONAL CHARACTERISTICS

3-13.3.1 Governing Dimensions: Dictated by requirements of specific equipment.

3-12.3.2 Sizing of Space

- A. Space required will vary according to type of system. Roof-top units require no mechanical space. Full air-conditioning will require more space than heating and ventilating only.
- B. Prior to system determination, allow 4-5% of gross floor area.

3-13.4 BASIC EQUIPMENT REQUIRED: Equipment as required by function. Storage and work area may be required by maintenance personnel.

3-15.5 REQUIREMENTS OF SUB-AREAS WITHIN MAIN SPACE: Not applicable.

3-13.6 PLANNING CRITERIA

3-13.6.1 Should be isolated from public areas of the facility.

3-13.6.2 Space that contains large, heavy pieces of equipment that are likely to be removed should have direct access to outside paved area.

3-13.7 GENERAL ENVIRONMENTAL PERFORMANCE REQUIREMENTS

3-13.7.1 Lighting

- A. Natural: Not essential.
- B. Artificial: Industrial lighting appropriate.

3-13.7.2 Acoustics

- A. Sound, Generation: Fan rooms, compressor rooms and pump areas, may generate considerable noise; electrical room generates minimal noise.

13-MECHANICAL

B. Sound, Isolation: Mechanical areas which generate sound should be isolated from all public spaces and from outdoor spaces that are used for recreational purposes.

3-13.7.3 Thermal: Heating equipment generates considerable waste heat. Staff areas should be well ventilated.

3-13.8 RELATIONSHIPS TO OTHER SPACES: No relationship, other than provision for staff access to space, preferably under cover.

3-14 LOCKER ROOM

3-14.1 ACTIVITIES AND USES ANTICIPATED: Area where staff changes into work clothes. Associated with washing, shower facilities, and staff toilets.

3-14.2 CHARACTER OF SPACE: Clean, functional, fresh colors.

3-14.3 DIMENSIONAL CHARACTERISTICS

3-14.3 Governing Dimensions

A. Horizontal Dimensions: Requirements based on size of lockers and aisle requirements.

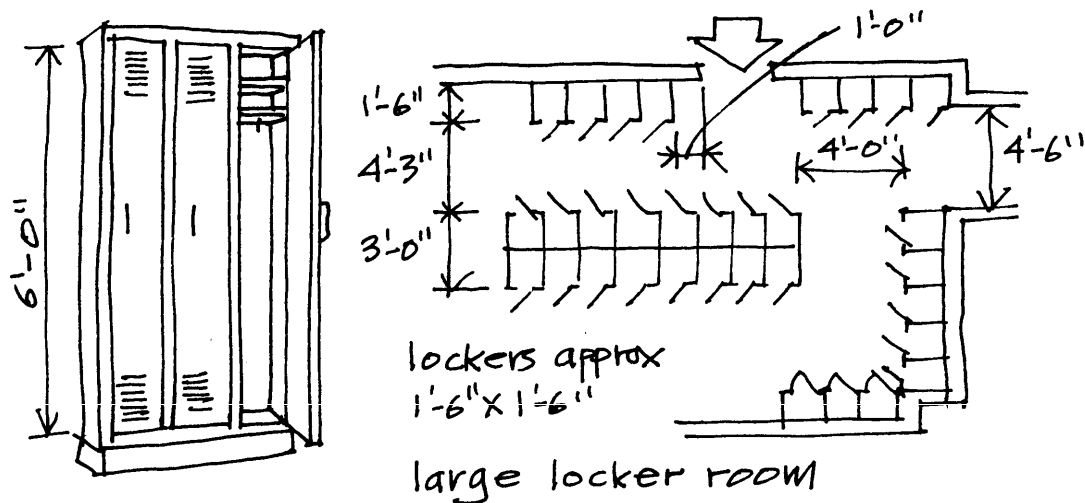

3-14.3.2 Vertical Dimensions: Minimum ceiling height 8'-0".

3-14.3.2 Sizing of Space: Should be sized to provide one locker and associated space for each employee who is required to change clothing for work purposes.

3-14.4 BASIC EQUIPMENT REQUIRED: Clothing lockers, benches.

3-14.5 REQUIREMENTS OF SUB-AREAS WITHIN MAIN SPACE: Not applicable.

3-14.6 PLANNING CRITERIA

3-14.6.1 In small club, lockers can be provided in hallways at staff entrances or in staff, toilet areas.

3-14.6.2 In large club, lockers should be in separate room and include provision for washing and showers.

3-14.7 GENERAL ENVIRONMENTAL PERFORMANCE REQUIREMENTS

14-LOCKER ROOM

3-14.7.1 Lighting

- A. Natural: Not essential.
- B. Artificial: Moderate lighting level. Fluorescent fixtures appropriate. See Table 4-7 for standards.

3-14.7.2 Acoustics

- A. Sound, Generation: Low activity area, but lockers generate noise.
- B. Sound, Isolation: Not critical.

3-14.7.3 Thermal: High standard of ventilation essential. Provide minimum of 12 air changes/hour.

3-14.8 RELATIONSHIPS TO OTHER SPACES: Related to staff entrance.

4-1 GENERAL

4-1.1 CONCEPT: Any building can be conceptualized as composed of a group of subsystems, each of which performs a function. The design of these subsystems is the major determinant of the cost and performance of the building. The subsystems are, to some extent, interrelated and may share some functions. For example, the exterior wall or interior partitions may perform a structural function. Thus, subsystems cannot be evaluated and chosen completely independently of one another. By focusing attention, during the early stages of design, on subsystems rather than the building as a whole, issues and alternatives are clarified, and major design decisions can be made on an orderly and systematic basis.

4-1.2 SUBSYSTEM ALTERNATIVES: This section provides information on subsystem alternatives that are appropriate to the Army club facility. Subsystems are reviewed on a generic basis, unrelated to specific building design or geographic location. The information given will serve as a useful check list and guide for subsystem choice while the general configuration of the building is developed. The following subsystems are reviewed:

- Structure
- Heating, ventilating, and cooling
- Envelope
- Interior partitions
- Ceiling
- Lighting

4-1.3 SUBSYSTEM COST: For each subsystem, except structure, a cost index is provided that shows the costs of subsystem types relative to one another, within the same subsystem group. The cost index is not transferable from one subsystem to another. Structural costs vary significantly from one location to another and, in addition, the structure may share roles with other subsystems such as exterior walls or interior partitions. For this reason no comparative cost index is given for structure.

4-1.4 LIFE CYCLE COST: The design of facilities constructed under Military Construction Programs must consider the potential economic impact of suitable alternate subsystems and components over the life cycle of the facility. This will include alternate considerations in such selection areas as structural systems, story heights, exterior and interior finishes, interior utility systems, and power supply

systems. Application of a formalized life cycle costing technique, if applied in the fullest sense, requires that life cycle cost data on each alternate subsystem and component be developed and used in the analysis. Thus, it must include the initial construction cost; and the operating, maintenance, and custodial costs associated with each alternate over the functional life of the facility. The utilization of a formalized life cycle costing technique will require additional effort in the design phase beyond that based on conventional design procedures. The technique will be used to evaluate the life cycle cost advantages of alternates which have the greatest potential to improve quality and/or functional efficiency at equal life cycle costs; to lessen the life cycle cost at no loss in quality and/or functional efficiency; or to both improve quality and/or functional efficiency and reduce life cycle cost. A brief summary of steps necessary to conduct the Life Cycle Costing Analysis is shown below:

- a. Development of a spectrum of candidate alternates.
- b. Approval by District of design alternates to be studied.
- c. Development of raw economic cost data for each alternate by the designer.
- d. Analysis of alternates by life cycle cost methods.
- e. Evaluating results of analysis and selection of design choices.

4-2.1 GENERAL: General principles of economy in the design of a building structure should apply to the design of club facilities. The diversity in range of total building sizes and individual space areas is such that each building design should be considered on an individual basis.

Minimum design requirements for structural design are established in DOD 4270.1-M, Section 6-3, and TM 5-809-1 through 11 series which identifies governing codes and service manuals and applicable specifications related to specific materials.

4-2.2 SPECIAL CONDITIONS: Additionally, recognition should be accorded special conditions that apply to a specific project location. Special conditions may include climatic considerations such as: wind loading, (including typhoons and hurricanes), snow loading, and permafrost (permanently frozen ground). Geologic conditions will affect the design of foundations, and seismic conditions are important special conditions. These conditions are addressed in the design standards established by TM 5-809-1 through-11.

4-2.3 DESIGN CRITERIA: The design criteria in Table 4-1 will require evaluation and determination for all club facilities based on the individual needs of each facility. Comments related to each consideration suggest issues that may dictate the definition of specific requirements.

Table 4-1 Structural Design Criteria

<u>Design Criteria</u>	<u>Comments</u>
a. Major material.	Determined by project architect or engineer. Important considerations include character of the region, the character of adjoining buildings on the installation, and the desired design image for the facility.
b. Planning module, horizontal.	This may be established by the wish to incorporate pre-designed subsystems within the building, e.g., ceilings, partitions, etc., which have limited modular adaptability.
c. Structural depth, horizontal members.	Governed by required span, loading, material, and the need to accommodate other components of the building within the structural envelope.

- d. Live load. Roofs: Determined by use, geographic, climatic and seismic data.
 Floor: (Figures interpolated from TM 5-809-1.)

Space	<u>Load in p.s.f.</u>
1- Entry	100
2- Dining	100
3- Bar	100
4- Kitchen	100
5- Ballroom/Multi-Use	125
6- Party Room	100
7- Recreation Room, Quiet	60
8- Recreation Room, Noisy	100
9- Administration Space	50
10- Rest Room	50
11- Storage	125
12- Maintenance Space	150
13- Mechanical Space	75
14- Locker Rooms	75
Circulation Space	100

- e. Span Ranges. Roof: Primary and secondary spans determined by occupancy requirements, and economy.
 Floor: For upper floors, determined by occupancy requirements of the floor below, and by economy, e.g., spans of a second floor will be determined by first floor occupancy requirements to the extent columns can be tolerated, combined with appropriate economy.
- f. Most economical bay. Bay sizes will be determined by occupancy and the need to provide for change in occupancy.
- g. Cantilevers. Determined by A/E design.
- h. Vertical module. Not controlling, since most of these facilities are of single or two-story configuration.

STRUCTURE

4-2.4 BASIC FRAMING ALTERNATIVES: Three basic framing alternatives for one-story clubs are shown in Table 4-2.

Table 4-2 Structural Framing Alternatives

<u>Vertical-Lateral</u>	<u>Horizontal</u>	<u>Comment</u>	<u>Basic Framing</u>
<p>a. Bearing and shear wall</p> <p>Wood, masonry concrete, braced steel</p>	<p>Deck/Beam, girder or truss:</p> <p>Wood, steel precast concrete</p>	<p>Structurally efficient system. Walls may double as exterior cladding. Does not readily allow for space expansion (one way only). Moderately heavy system.</p>	
<p>b. Two way rigid frame:</p> <p>Steel, concrete</p>	<p>Deck/Beam, girder</p> <p>Steel, concrete</p>	<p>Structurally efficient system. Requires separate cladding system. Flexible for space planning. Allows for two-way space expansion. Lightweight system.</p>	
<p>c. Cantilevered columns:</p> <p>Steel, concrete</p>	<p>Deck/Beam, girder or truss :</p> <p>Wood, steel, precast concrete</p>	<p>Structurally efficient system. Requires separate cladding system. Columns may be design element. Flexible for space planning. Allows for two-way space expansion.</p>	

4-3.1 STANDARDS: DOD 4270 1-M, Chapters 8 and 9, establishes minimum acceptable standards for Heating, Ventilating and Air Conditioning (HVAC) systems designed for new club facilities and for the rehabilitation of old facilities. Notes relating to preferred HVAC systems in club facilities are also included in DA PAM 230-1, Chapter 5, Sections 9-11, pages 5-6.

4-3.2 OBSOLESCENCE: Due to physical wear over the service life of equipment, and to the introduction of higher standards of code and performance criteria, many HVAC systems in older facilities do not provide an acceptable level of service.

In the selection of HVAC systems, consideration should be given to the long term implications for obsolescence as they affect performance and cost.

4-3.3 SYSTEM EXTENSION: In planning facilities for future change, recognition of the need for extension of a single HVAC system, or series of similar systems, should be made. For heating this may involve the provision of space for the addition of furnaces and air handling units to couple with the existing systems, or for the addition of elements of sectionalized equipment. In either event the controls should be mutually responsive and complementary.

4-3.4 CONTROL: Heating and cooling distribution systems should be designed to respond to varying contributions of heat gain and loss due to conditions external to the systems themselves. Notable causes of differential temperatures are solar heat gain through the fabric of the building, loss due to exposure to prevailing winds, and independent internal heat sources such as kitchen equipment, open fireplaces, and even body emissions in areas of dense occupancy.

4-3.5 NOISE AND DRAFTS: Complaints of excessive noise are generally attributable to excessive air velocities, poor positioning of air diffusers and return air grilles relative to the occupants, or to inadequacies in the attachment of the insulation of the duct system. The first two also contribute to discomfort due to excessive drafts.

While occasional compromises must be made in the rehabilitation of existing buildings, observance of new construction standards defined by DOD 4270.1-M should result in no deficiencies in new buildings.

4-3.6 SUB-SYSTEM ALTERNATIVES: A comprehensive description of generic systems for air conditioning can be found in the ASHRAE Guide and Data Book, Chapter 1.

For the purpose of establishing eligibility and other limitations on design criteria and weather zones, reference should be made to document DOD 4270.1-M, Table 8-2 and Table 8-3.

4-3.7 DESIGN ALTERNATIVES

4-3.7.1 Heating and Cooling: The following systems may provide heating only, cooling only, or both heating and cooling.

4-3.7.2 Central System Packaged Unit: Central system generally implies a single, central heating and cooling equipment location, which distributes heating water and chilled water to one or more air handling units. One central air handling unit may serve an entire building, or any major fraction thereof, i.e., one system per floor, etc. A packaged unit includes, as a manufactured assembly, heating, cooling, and air handling equipment. Such a unit may serve any fraction of a building.

4-3.7.3 Mixed Systems: A building may be served by one or more types of systems types, i.e., the perimeter of a building may be served by a fan coil or induction unit system, while the interior of the building may be served by an all-air type system.

4-3.7.4 Controls: Pneumatic, electric and/or electronic.

4-3.7.5 Heating and Reheat Coils: Steam, heating water or electric.

4-3.7.6 Air Outlets (diffusers, registers, grilles, etc.)

- A. Configuration: Square, round, rectangular or linear.
- B. Type: Adjustable or fixed louvers, blades, perforated plates, or slots.
- C. Location: Ceiling, wall, floor, ceiling T-bar, or air handling light troffer.

4-3.7.7 Supplementary Heating Units

- A. Energy Source: Steam, heating water, or electric.
- B. Type: Convection, radiation, or combination.
- C. Location: Floor, ceiling or wall.

4-3.8 GENERIC SYSTEMS SUITABLE FOR ARMY CLUBS

4-3.8.1 Terminal Unit: Fan Coil and Unit Ventilator (1)

A. Description: The unit receives steam or heating water and chilled water from a central plant and outside air through wall louvers or from a central, ducted system. The unit has a fan, coils, and filters, and supplies warm or cool air to the room.

- B. Types:
- two pipe, change-over
 - three pipe
 - four pipe

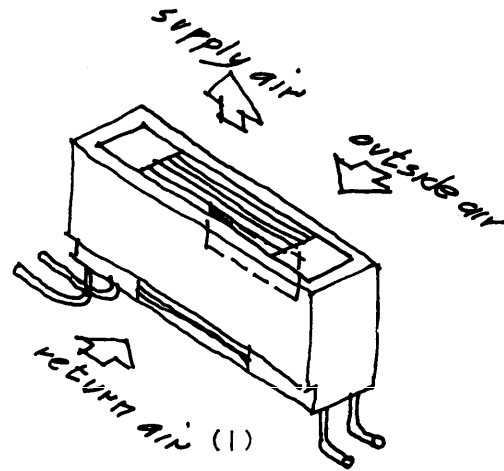

4-3.8.2 Terminal Unit: Air-water Induction (2)

A. Description: The unit receives high pressure, ducted, primary air from a central system, and induces room air. The mixture is supplied to the room. The unit has air induction nozzles and a coil.

- B. Types:
- two pipe, change-over
 - three pipe
 - four pipe

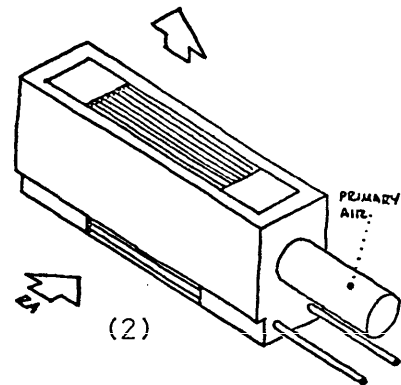

4-3.8.3 Terminal Unit: Self Contained (3)

A. Description: The unit contains an electric refrigeration unit, and may have either an electric or hot water coil.

- B. Types:
- thru-the-wall
 - split system
 - electric-hydraulic

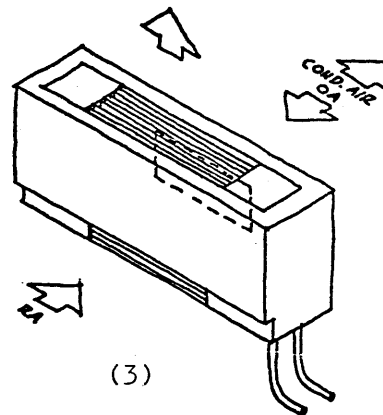

4-3.8.4 Single Duct: Air Water (1)

A. Description: A single duct from central air handling equipment delivers cool air throughout the building. Branch ducts from the distribution system, through terminal units, supply air to room air outlets, usually located in the ceiling.

B. Types:

- low velocity reheat- central system
- low velocity reheat - packaged equipment
- variable volume reheat - central system
- variable volume reheat - packaged

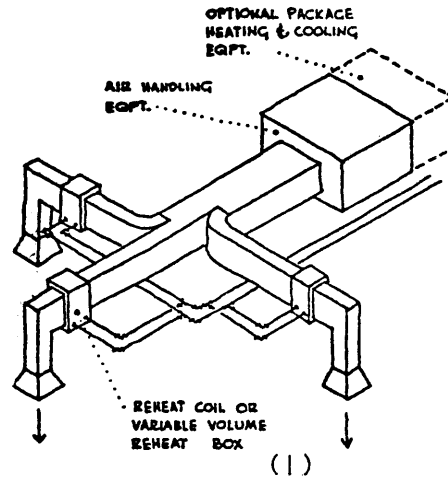

4-3.8.5 Single Duct: All-Air (2)

A. Description: A single duct from central air handling equipment delivers air throughout the building. Branch ducts from the distribution system, through terminal units, supply air to room air outlets, usually located in the ceiling.

B. Types:

- single zone, central system
- single zone, packaged equipment
- variable volume, central plant
- variable volume, packaged equipment
- integrated ceiling, all-air induction, central plant
- integrated ceiling, all-air induction, packaged equipment
- variable volume, ceiling unit, central plant
- variable volume, ceiling unit, packaged equipment

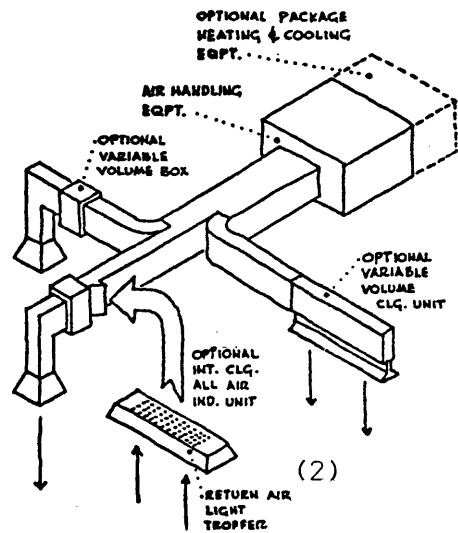

4-3.8.6 Multi-Zone (1)

A. Description: Each control zone has a separate duct from the air handling equipment to the control zone. At the central air handling equipment, warm air and cool air are blended by dampers to control the air temperature being supplied to the zone.

B. Types:

- central plant
- packaged equipment

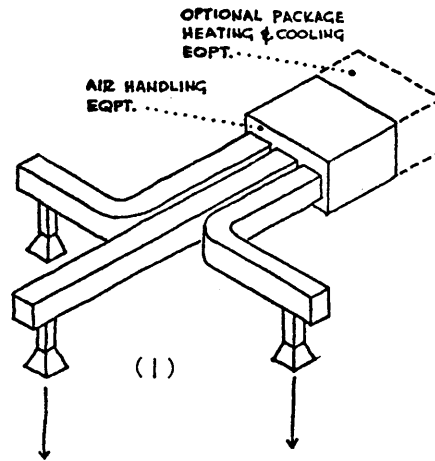

4-3.8.7 Double Duct (2)

A. Description: From the central air handling equipment there are throughout the building, are a pair of distribution ducts--one with cool air and one with warm air. For each control zone, a branch duct is taken from each of the main ducts through a terminal mixing unit, and to the room in a common duct.

B. Types:

- low velocity, central plant
- low velocity, packaged equipment
- medium velocity, central plant
- medium velocity, packaged equipment

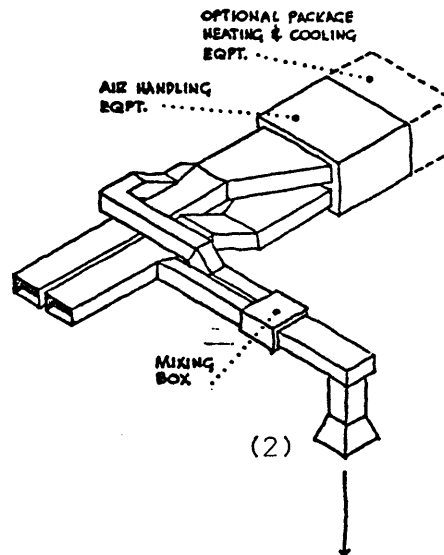

Table 4-3 H.V.A.C. Cost Performance Summary

		Cost Index(base 100)		Performance	3 Temp. Control	4 O.A. Vent	5 Air Distribution	6 Noise	7 OA/RA Control	8 Humidity Control	9 Cold Climate*	10 Dry Climate*	11 Adaptability	12 Durability	13 Economy Cycle	14 Heat Transfer***	15 Operating Cost**
		1 high	2 low														
Terminal Unit Fan Coil	2 pipe	130	110		-	+	+	+	0	0	+	+	0	0	N	N	+
	3 pipe	140	120		+	+	+	+	0	0	+	+	0	0	N	N	0
	4 pipe	160	140		+	+	+	+	0	0	+	+	0	0	N	N	+
Terminal Unit Unit Vent	2 pipe	110	90		-	+	0	0	+	0	+	+	-	0	Y	N	+
	3 pipe	130	110		+	+	0	0	+	0	+	+	-	0	Y	N	+
	4 pipe	140	120		+	+	0	0	+	0	+	+	-	0	Y	N	+
Terminal Unit Air-Water Induction	2 pipe	170	150		-	+	+	+	+	+	+	+	-	+	N	Y	0
	3 pipe	180	160		+	+	+	+	+	+	+	+	-	+	N	Y	+
	4 pipe	190	170		+	+	+	+	+	+	+	+	-	+	N	Y	0
Terminal Unit Self Contained	thru-wall	140	120		+	+	+	-	0	0	+	0	0	-	Y	N	0
	split systems	160	140		+	+	+	-	0	0	+	0	0	-	Y	N	-
	elec. hyd.	140	120		+	+	+	-	0	0	+	0	0	-	Y	N	0
Single Duct, Air water	L-V reheat (1)	160	140		+	+	+	+	+	+	+	+	+	+	Y	Y	0
	L-V reheat (2)	140	120		+	+	+	+	+	+	+	+	+	+	Y	Y	0
	V-V (1)	170	150		+	+	+	+	+	+	+	+	+	+	Y	Y	+
	V-V (2)	140	120		+	+	+	+	0	+	+	+	+	+	Y	Y	+
Single Duct, all air	single zone (1)	160	140		+	+	+	+	+	+	+	+	-	+	Y	Y	+
	single zone (2)	140	120		+	+	+	+	+	+	+	+	-	+	Y	Y	+
	V-V (1)	150	130		+	+	+	+	+	0	+	+	+	+	Y	Y	+
	V-V (2)	130	110		+	+	+	+	0	0	+	+	+	+	Y	Y	+
	integ. clg. (1)	190	170		+	+	+	+	+	0	-	+	+	+	Y	Y	+
	integ. clg. (2)	160	140		+	+	+	+	+	0	0	0	+	+	Y	Y	+
	V-V clg. (1)	150	130		+	+	0	+	+	0	-	0	+	+	Y	Y	+
	V-V clg. (2)	130	110		+	+	0	+	+	0	0	0	0	+	Y	Y	+
Multi-zone	central	160	140		+	+	+	+	+	+	+	+	0	+	Y	Y	+
	packaged	140	120		+	+	+	+	+	+	+	+	0	0	Y	N	+
Double Duct	L-V (1)	160	140		0	+	+	+	+	+	+	+	0	+	Y	Y	+
	L-V (2)	140	120		0	+	+	+	+	+	+	+	0	+	Y	Y	0
	M-V (1)	170	150		+	+	+	+	+	+	+	+	0	+	Y	Y	+
	M-V (1)	140	120		+	+	+	+	+	+	+	+	0	+	Y	Y	+

Notes: + = excellent
 0 = good
 - = poor
 Y = applicable
 N = not applicable

* As defined by DOD 4270.1-M.
 ** Includes energy, maintenance, replacement.
 *** Indicates applicability of devices such as thermal heat pipe, rotary heat exchanger, etc.

4-4.1 GENERAL: Envelope refers to the combination of opaque and transparent materials that sheath the building exterior. The envelope may be entirely non-load-bearing or portions of it may form the vertical structure of the building. The envelope may be entirely fixed or portions may be movable in the form of operable sash or ventilation louvers.

4-4.2 FUNCTIONS: The prime function of the envelope is to provide a weatherproof, durable protection to the building exterior. In addition; the envelope provides insulation to the interior from outside ambient temperature and solar heat gain.

4-4.3 ENERGY CONSERVATION: The envelope is a major source of heat gain or loss to the building interior. Heat gain and loss must be compensated for by the air-conditioning and heating systems, and inadequate insulation or excessive solar heat gain through glass will result in greatly increased energy usage, and consequent operating cost increase. For this reason the extent, type and location of glass, and the proposed materials should be carefully reviewed with the mechanical engineer as design proceeds.

4-4.4 APPEARANCE: The envelope is a major determinant of building appearance. Besides the familiar attributes of form, color and texture, appearance is heavily influenced by maintenance. Materials that weather well and require little maintenance will be of overall benefit to the building appearance. Maintenance costs of all exterior materials should be carefully considered, not only as an aspect of life cost, but because high maintenance cost may result in insufficient maintenance of the building exterior and consequent deterioration of appearance.

4-4.5 ENVELOPE DESIGN ALTERNATIVES

4-4.5.1 Poured-in-place Concrete: (1)
Usually performs a structural function.
Finishes include:

- A. Integral Finish: Natural, exposed aggregate, bush-hammered, sand-blasted, flat, fluted, sculptured, etc.
- B. Applied Finish: Masonry veneer, ceramic veneer, plaster, water proofing, painted surface, etc.

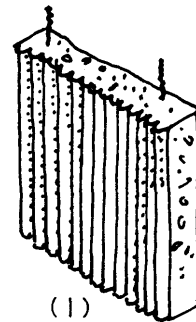

ENVELOPE

4-4.5.2 Masonry: May be structural. Can be single wythe or a grouted double wythe, or cavity wall. Masonry units can be concrete block, brick, structural glazed tile, stone, etc. A wide variety of surface finishes, bond and joint patterns, and unit sizes are available. (1)

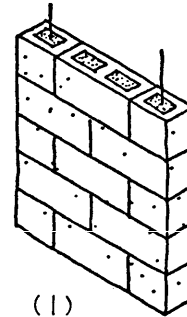

4-4.5.3 Stud Walls: Use metal or wood studs, covered with a sheathing of cement plaster, or sheet materials such as plywood, hard board, or cement-asbestos board. Solid wood siding or wood shingles are also used. A variety of plaster textures are available, with color either integral or applied. Sheet materials may be factory or site-finished. (2)

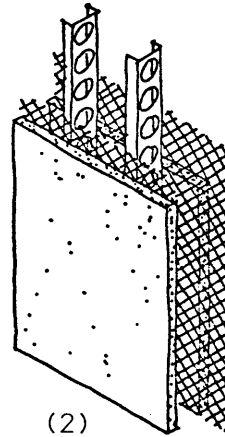

4-4.5.4 Curtain Walls: A wall assembly consisting of a metal mullion grid with infill panels of an opaque, translucent or transparent material. (3)

Mullion grid may be of aluminum, steel, stainless steel, bronze, etc. Infill panels may be single piece or composite panels with insulated cores and an inside and outside facing material.

Opaque panels may be metal, precast concrete, plastic or assemblies of cement-asbestos board, gypsum board, hard board, etc.

Non-opaque panels may be glass or plastic mounted in fixed or operable sashes.

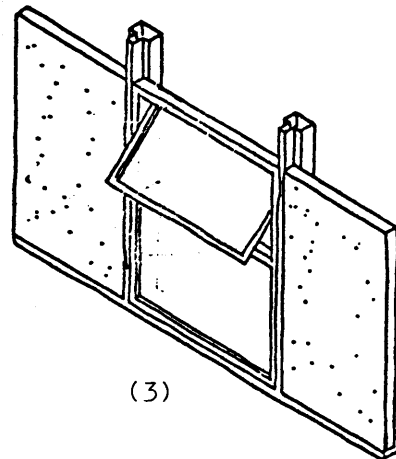

4-4.3.5 Wall Panels Subsystem: A wall assembly consisting of panels spanning from floor to floor, with no mullion grids. Panels may have voids permitting insertion of translucent or transparent materials or doors. Materials are similar to curtain walls. (1)

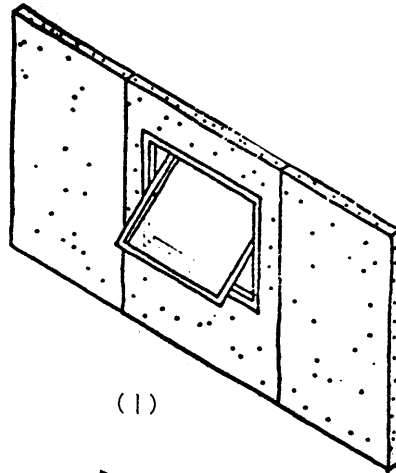

(1)

4-4.3.6 Operable Sash: May span entire opening from floor to floor or be a part of a curtain wall or wall panel system, or be inserted in a concrete, or masonry, or frame wall. (2) Materials may be:

- A. Sash Frame: Aluminum, steel, stainless steel, bronze, wood
- B. Glazing: Plastic, sheet glass, plate glass, polished plate glass, clear glass, tinted glass, wire glass, safety glass, tempered glass, textured glass, sealed double pane unit, etc.

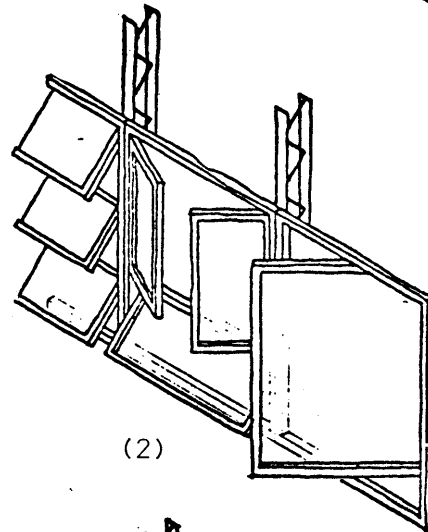

(2)

4-4.3.7 Fixed Sash: Nature and materials similar to operable sash. May also be directly attached to concrete or masonry walls, using neoprene gasketing. (3)

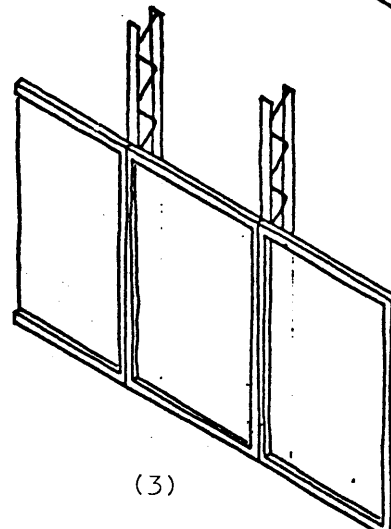

(3)

ENVELOPE

Table 4-4 Envelope: Cost/Performance Summary

		POURED-IN PLACE CONCRETE			MASONRY					STUD WALLS			CURTAIN WALLS			FINISHES											
		plain	brick veneer	cer. tile veneer	stone veneer	brick, 1 course	brick, 2 course	conc.blk 1 course	conc.blk.2 course	stone	glazed strct.tile	met. plaster	wood, plaster	wood, sheet mats.	wood, solid wood	curtain wall	wall panels	operable sash	fixed sash	concrete	integral fin.	masonry bonds	masonry joints	waterproofing	paint	met. integral	met. applied
Cost Index:	1. high		960	450	680	180	225	160	225	180	250	105	100	135	160	400	400	310	290		55	90	15	5	10	65	225
	2. low		310	400	590	160	180	135	180	180	200	100	90	110	140	250	250	270	250		20	0	0	0	10	50	190
Performance:																											
Durability:	3. poor																										
	4. good			0								0	0	0	0	0	0	0						0	0	0	0
	5. excellent	0	0	0	0	0	0	0	0	0	0										0	0					
Appearance:	1. poor	0																									
	2. good							0	0	0	0	0	0	0	0	0	0	0			0			0			
	3. excellent		0	0	0	0	0			0				0								0			0	0	
Insulation:	1. poor	0				0	0										0	0									
	2. good		0	0	0	0	0	0	0	0	0	0	0	0	0	0	0										
	3. excellent																										
Adaptability	1. poor	0								0																	
	2. good		0	0	0	0	0	0	0	0																	
	3. excellent											0	0	0	0	0	0	0									
Adaptability to services:	1. poor	0	0	0	0	0	0	0	0	0																	
	2. good											0	0	0	0	0	0										
	3. excellent																										
Ease of Removal - Relocation:	1. poor	0								0																	
	2. good		0	0	0	0	0	0	0	0																	
	3. excellent											0	0	0	0	0	0	0									

4-5.1 GENERAL: Partitions are conveniently grouped in five main categories, which relate to their degree of locational permanence. These categories are: fixed, replaceable, demountable, portable, and operable.

4-5.2 FIXED PARTITIONS: Fixed partitions are intended to remain in place for the life of the building. Though any wall can be demolished, walls that are part of the building Support structure, or are reinforced concrete or masonry walls, are obviously relatively difficult to remove, and should be considered fixed.

4-5.2.1 Characteristics: Fixed partitions are generally constructed of precast or poured-in-place concrete (1), or masonry (2).

4-5.2.2 Use: Fixed partitions should be carefully located so that they will not limit building flexibility. Desirable locations are at the building perimeter, or associated with other permanent elements, such as toilets, stairs, and elevators. In seismic areas, interior fixed partitions may serve as lateral resisting elements and be located for structural purposes. The location of these partitions is most critical because their later removal is all but impossible.

4-5.3 REPLACEABLE PARTITIONS: Replaceable partitions are non load-bearing, but are not reusable when removed.

4-5.3.1 Characteristics: Replaceable partitions are constructed of metal lath, studs and plaster, gypsum board and studs, or un-reinforced concrete masonry, solid gypsum blocks or tiles. (3)

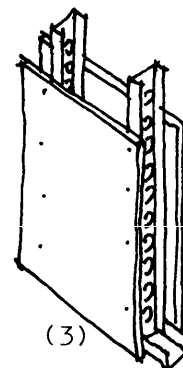
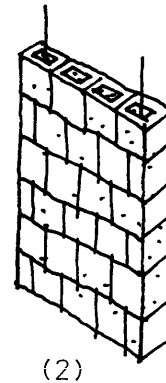
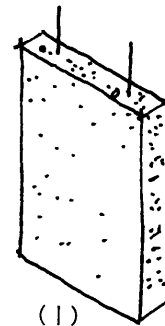

INTERIOR PARTITIONS

4-5.3.2 Uses: Replaceable partitions are used where eventual relocation is a possibility, but frequent movement is not anticipated.

4-5.4 REMOUNTABLE PARTITIONS:
Remountable partitions are defined as relocatable partitions that are an assembly of structural frames, panels and trim which together provide a rigid, finished space-dividing assembly.

4-5.4.1 Characteristics: The stability of this system usually is achieved through the anchorage of floor and ceiling channel members into which the vertical structural studs clip. Snap-on trim is applied to cover raw edge conditions. There are two general systems:

- A. Stud and Facing Panels:
Panels on either side of the structural frame are independent and can therefore be removed and replaced on one side of the partition without interrupting the activity of the other. Panel faces may also be of different materials or finishes. The void may be filled with insulation to increase the sound attenuation rating of the wall or used for the installation of concealed electrical or plumbing lines. (1)
- B. Post and Panel: A system of posts are attached to a ceiling track and a floor track and the spaces between are filled with a composite panel, glazing or doors. (2)

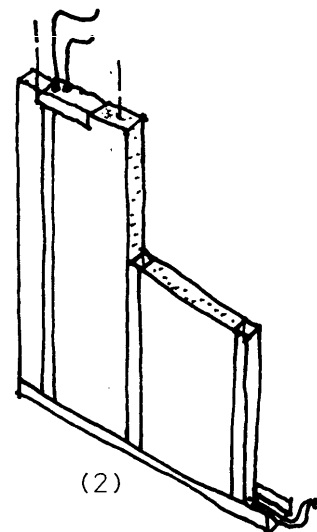
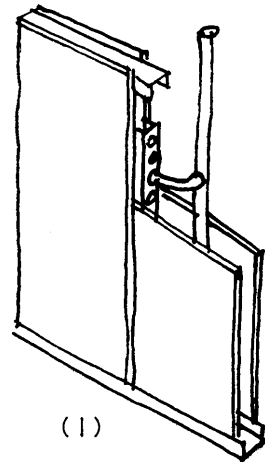

4-5.4.2 Uses: These systems are appropriate when partitions are expected to be moved fairly infrequently, as part of major space rearrangements. Trained personnel are necessary to move these partitions.

4-5.5 PORTABLE PARTITIONS:
Portable partitions are defined as relocatable partitions generally having prefinished surfaces, both sides, and being fabricated as a single repetitive unit that can be simply handled and erected by non-skilled labor. (1)

4-5.5.1 Characteristics: This partition is light in weight and is capable of Attachment to floors and ceilings by friction or minimal mechanical means. These two characteristics tend to reduce the effectiveness of such systems as acoustic separators, since weight is a function of density and continuous firm attachment is a requirement for optimizing the reduction of sound transfer through joints in the assembly. Portable partitions, for similar reasons, tend not to be well-suited for resistance of lateral loading, either as impact or sustained loads.

4-5.5.2 Uses: These systems are appropriate when it is expected that walls will be moved relatively frequently, and where their inability to house electrical and plumbing services is not disadvantageous.

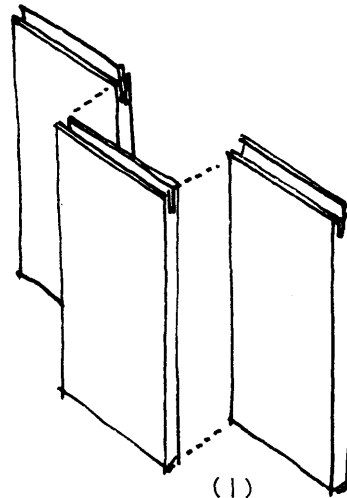

INTERIOR PARTITIONS

4-5.6 OPERABLE PARTITIONS:

Operable partitions are defined as those that are readily movable along tracks for the subdivision of a large space into two or more smaller spaces. When not in use, they stack against walls perpendicular to the path of travel, or into a storage pocket designed for that purpose.

4-5.6.1 Characteristics:

Operable partitions vary widely, from heavy rigid panels that interlock when in position to provide a very robust and durable wall (1), to a light fabric covered accordion folding door which serves primarily as a visual barrier (2). Light-weight doors are generally manually operated, while heavy panelized walls are motor operated.

4-5.6.2 Uses: These partitions are used when immediate and easy space subdivision is necessary.

4-5.6.3 Decorative Limitations:

While the space adaptability achievable through the use of readily movable partitions is obvious, their use tends to limit the decorative character of spaces so subdivided, and it is difficult or impossible to change the character or to redecorate their factory applied finishes.

Hence, surface finishes of operable partitions should be of neutral colors, or in natural materials, that will not establish the dominant design character of the space affected. Changes may then be introduced through furnishings, drapes, carpet replacement and redecoration of non-movable wall surfaces and lighting.

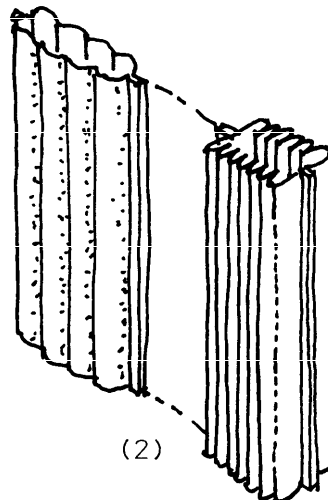
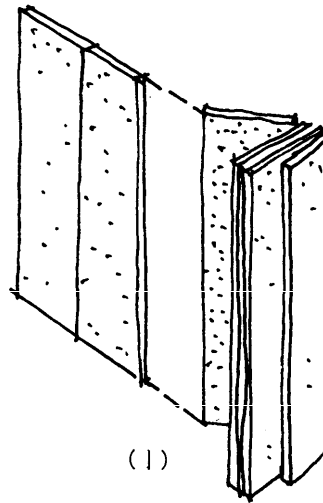

4-5.7 FINISHES:

All partitions can receive a variety of finishes. Choice of finish should be determined on the basis of use, potential abuse, appearance, cost and expected degree of performance.

4-5.7.1 Types of Finish:

The general characteristics of a group of commonly applied finishes are noted below:

A. Plastic laminates:

These are available in a variety of solid colors and patterns, with minor textural variations. These provide a very hard wearing surface, resistant to stain, and easily cleaned. If damaged, however, patching is not possible.

B. Vinyl fabric:

Thin sheet plastic surfacing, applied in the factory or in the field. Available in a variety of textures, colors, and patterns. Easily cleaned, and can be patched. Care necessary to ensure use of correct adhesives.

C. Wood veneer:

Generally hardwood: used where the variety and natural texture of wood is desired. Applied by adhesive: normal wood finishes used for protection.

D. Imitation wood veneer:

Similar to A, but using photographically reproduced wood veneers. Popular because wood grain in finish conceals marks and minor blemishes, and is much easier to maintain than natural wood.

E. Paint:

Inexpensive, easily marked and damaged, but easy to replace. Care must be taken to select correct paint type for use, since there are a great variety of paint materials.

INTERIOR PARTITIONS

Table 4-5 Partitions: Cost/Performance Summary

			FIXED		REPLAC- ABLE		DEMOUNT- ABLE			OPER- ABLE		FINISHES					
			concrete	masonry	plaster	block	post & panel	stud & facing	panel	portable	accordion	panel	plastic lamin.	vinyl fabric	wood veneer	imitation wood veneer	paint
COST INDEX (base 100)	1	high	450	135	100	135	200	175	200	300	225	350	175	65	400	100	10
	2	low	310	220	75	220	125	90	100	225	200	300	100	25	40	50	75
PERFORMANCE																	
Fire Rating:	3	none															
	4	incombustible									0*	0*					
	5	to 1-hour								0							
	6	to 2-hour					0	0	0								
	7	+ 2-hours	0	0	0	0											
Acoustics: S.T.C.	8	28-42								0							
	9	up to 46								0	0						
	10	36-52					0	0	0								
	11	wide range	0	0	0	0											
Lateral Load p.s.f.	12	0-5									0	0					
	13	0-7.5								0							
	14	0-15	0	0	0	0	0	0	0								
Wiring Access	15	none	0	0		0				0	0	0					
	16	difficult			0				0								
	17	easy					0	0									
Clearance for piping	18	none	0	0		0			0	0	0	0					
	19	limited			0		0	0									
	20	good															
Relocation rate, ft/man hour	21	demolition	0	0	0	0											
	22	1-4					0	0	0								
	23	30-80								0							
	24	very fast									0	0					

* Operable partitions may be incombustible: not used for fire separations

4-6 CEILING

4-6.1 FUNCTIONS: The primary functions of the ceiling as a design element are that it provides visual protection from view of the underside of a structure; controls the acoustic properties of the space containing the ceiling; and may provide a standard of fire resistive protection to that part of the building and its structure directly above.

An additional function, that of providing an aesthetically pleasing surface, tends to be regarded as the least important since no definitive standards of performance exist, unlike those for fire-resistive construction or acoustics.

The ceiling surface often provides a plane which many secondary building subsystems penetrate. These include mechanical air distribution diffusers and grilles, fire sprinkler systems, electrical alarm systems, lighting fixtures, public address speakers, emergency exit signs and occasionally penetrations by pipes and ducts exposed to view from remodeling, presumably through expedience.

4-6.2 APPEARANCE: Common deficiencies in ceiling appearance include pattern staining of dirt accumulating around return air registers, accentuated by the introduction of replacement tiles, often of another design than the original ceiling.

The key to good appearance in ceiling design lies in the reduction of the number of elements permitted to occur in the ceiling plane and the integration of those that are exposed into a pattern using similar forms, e.g., square fixtures, air registers, speaker boxes, etc. Many manufacturers produce ceiling assemblies in which the lighting fixtures, acoustic tile panels and air diffusers are integrated with a consequent gain in appearance.

4-6.3 FIRE RESISTIVE STANDARDS: The most stringent performance requirement of a ceiling system is the need to conform to standards of fire-resistive construction.

The National Fire Protection Association defines assemblies of materials of construction and tests and rates them for fire resistance.

Fire resistive standards are generally expressed for a complete structure/ceiling assembly, and approvals refer to assemblies that are identical in every detail with those tested. Hence, ceiling systems are seldom given a fire resistance rating independent of accompanying structure elements.

4-6.4 REFLECTIVITY: Where ceilings are to be used to reflect indirect lighting, the reflective values of the ceilings should exceed 80%. Where this is not required, there is considerable scope for enriching ceiling surfaces through the introduction of color and materials.

CEILING

4-6.5 SOUND ATTENUATION: A suspended ceiling acts as a plane of sound separation between spaces. When partitions do not penetrate the ceiling, the ceiling plane becomes the critical sound attenuation element.

Note that the attenuation capability of the ceiling plane need only be approximately one-half that of the partitions, since sound must travel through two ceiling planes. (1)

Other critical aspects of ceiling sound attenuation include the presence of openings in the ceiling (return air registers for example) and the effectiveness of partition head attachment in ensuring that sound cannot leak over the top of the partition. (2)

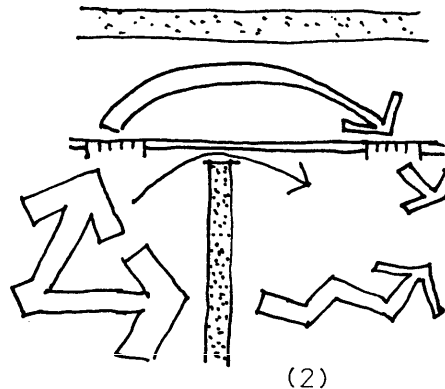
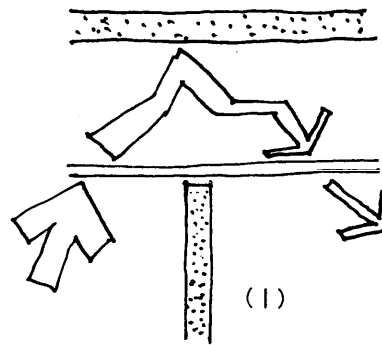

4-6.6 SOUND ABSORPTION: The ceiling provides a large area for the absorption of sound. Quiet spaces and dining areas should use highly absorbent ceiling materials. Large multi-use rooms should be analyzed by an acoustical engineer to provide criteria for absorption standards and material recommendations.

4-6.7 INTEGRATED CEILING SYSTEMS: Pre-engineered ceiling systems are available in which ceiling materials are integrated with lighting fixtures, air diffusers, and sometimes sprinkler heads. Most assemblies offer a selection of ceiling/lighting types including three dimensional coffers, luminous ceiling, and flat panels to receive surface mounted or recessed fixtures.

4-6.8 CEILING TYPES: There are three generic types of ceiling to be considered. These are:

A. Direct Application to Structure: (1) The direct application of coatings or sheet materials to the building horizontal structure. Materials used are:

- paint, stain: applied to concrete, metal deck or wood deck
- Gypsum board: applied to wood joists
- acoustic tile: glued or mechanically fastened to wood joists, concrete, or metal deck

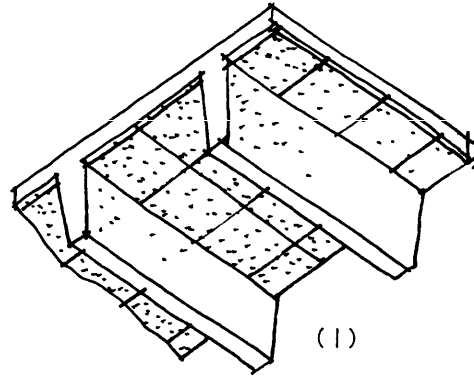

B. Grid and Panel Type (2),
A suspended grid assembly supporting infill panels, light fixture, and HVAC components. Materials used are:

- ceiling grid assembly: aluminum or steel
- in-fill panels: metal pans, tiles made of glass fiber, wood fiber, mineral fiber, or ceramic
- finish: natural, painted, plastic-coated

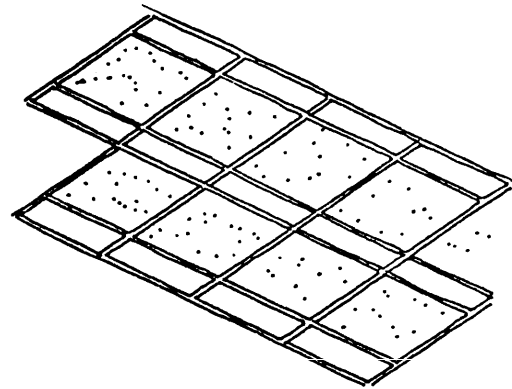

C. Suspended Plaster Ceiling: (3)
The use of plaster materials hung on furring members below the horizontal structure. Materials used are:

- channels: steel, untreated or galvanized
- plaster: gypsum plaster, cement plaster, acoustical plaster

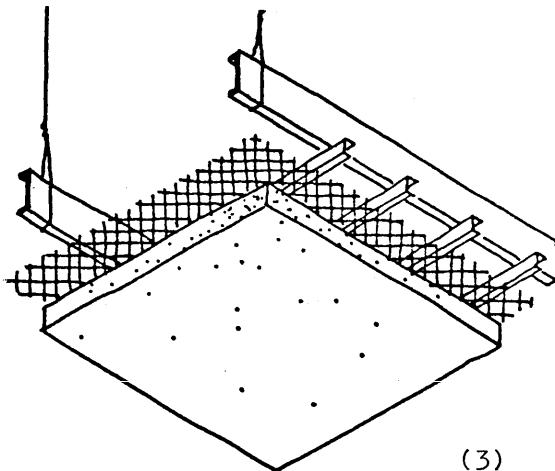

CEILING

Table 4-6 Ceilings: Cost/Performance Summary

		DIRECT APPLICATION			GRID & PANEL SUSPENDED						SUSPENDED PLASTER		
		paint	gyp.board	acous.tile	min.fiber tile	fiberglass	wood fiber tile	gyp.board	perf.alum.pan	st. stl. pan	cement	gypsum	acoustical
COST INDEX (base 100)	1. high	15	100	100	180	180	115	110	210	500	210	115	165
	2. low	10	50	50	125	110	100	100	200	415	190	100	100
PERFORMANCE													
Fire rating	3. none - + 2 hours		0		0	0	0	0	0	0	0	0	0
	4. dependent on structure	0		0									
Accessibility	5. none												
	6. limited		0								0	0	0
	7. good	0		0	0	0	0	0	0	0			
Compatibility HVAC	8. limited		0								0	0	0
	9. good	0		0	0	0	0	0	0	0			
Lighting	10. limited										0	0	0
	11. good	0	0	0	0	0	0	0	0	0			
Dimensional													
Flexibility	12. limited				0	0	0		0	0			
	13. good	0	0	0				0			0	0	0
Durability	14. fair	0	0	0	0		0	0				0	0
	15. good					0			0		0		
	16. excellent								0				

* Note: Acoustic capability of all systems are comparable, depending on materials and design.

4-7.1 GENERAL: Consideration of lighting requirements for club facilities should include both natural and artificial sources, both from a quantitative and a qualitative viewpoint.

Programming and design decisions should be made by rational process whereby the most beneficial performance can be obtained at an acceptable cost. Any cost/benefit analysis should take into consideration the service life of design alternatives under consideration, their energy consumption, and their effect on heating and cooling energy usage.

4-7.2 NATURAL LIGHTING: Natural lighting should be considered to be most desirable for those activity areas such as lounges and dining rooms, where the occupants can enjoy varied natural light and outside views. For other activities, such as administrative offices and staff work spaces, planning for natural lighting and view by articulation of the exterior wall or by the introduction of overhead skylights, can be beneficial. Glare from direct sunlight should be carefully controlled by the provision of awnings, louvers or blinds for times of excessive exposure.

4-7.3 LIGHTING DESIGN AND EVALUATION: Assessment of the worth of natural lighting is largely subjective. Practical considerations include the degree to which artificial light can be saved by the introduction of perimeter switching zones that would facilitate the saving of power during daylight hours. A staccato-like rhythm of alternating narrow vertical windows and solid walls can often detract from the quality of light and, by causing uncomfortable glare, conflict with the implied intent to provide a view.

4-7.4 NEED FOR UNIFORM CRITERIA: It is recognized that many of the tasks performed in a club do not require great visual acuity. This particularly applies to areas such as the bar and dining room. Lighting criteria in these areas should be pursued more to obtain an attractive and appropriate atmosphere, rather than attempting to maintain uniform high lighting standards.

4-7.5 PRINCIPLES: General principles of good lighting will dictate that adequate illumination is provided at the working plane to perform a given task, that contrasts between the intensity of light at the source and its immediate surrounding is controlled, and that glare and reflections are minimized.

4-7.6 LIGHTING STANDARDS: Design requirements for lighting should comply with the recommendations of the IES Lighting Handbook. (See DOD 4270.1-M, Section 7, page 1.)

The levels of illumination recommended for the generic space types are shown in Table 4-7.

LIGHTING

Table 4-7 Lighting Standards for Generic Spaces

<u>Generic Space</u>	<u>Ft. Candles on Task</u>
1. - Entry, incl. secondary entries:	
(entrance foyer)	30
coat room (locker rooms)	20
telephone room (telephone equip. room)	20
2 - Dining (dining areas)	
cashier station	50
(intimate type, light environment)	10
(intimate type, subdued environment)	3
(for cleaning)	20
(leisure type, light environment)	30
(leisure type subdued environment)	15
(quick service type, bright surroundings)	100
(quick service type, normal surroundings)	50
(food displays, twice normal but not less than:)	50
maitre'd station	NA
waitress station	NA
serving center	NA
3 - Bar all sub-spaces	NA
4 - Kitchen	
all sub-spaces (kitchen, commercial)	70
5 - Ballroom/Multi-Use	
(dance halls)	5
(auditoriums, assembly)	15
(auditoriums, exhibition)	30
(auditoriums, social activities)	5
dressing rooms (locker rooms)	20
6 - Party all types - See Dining, Ballroom & Recreation	
7 - Recreation, quiet	
reading (lounge and reading rooms)	30
lounge (lounge and reading rooms)	30
T.V. room	NA
8 - Recreation, noisy	
games (table games)	30
pool table	50



<u>Generic Space</u>	<u>Ft. Candles on Task</u>
9 - Administration	
office, general (reading poor reproduction)	70
office, cashiers (accounting office)	70
reproduction room (business machine operation)	70
10 - Restroom	
toilets (toilets and washrooms)	30
powder room (grooming, shaving, make-up)	50
11 - Storage	
(inactive)	5
(active, medium bulky)	20
12 - Mechanical	
all sub-spaces (utility room, general)	20
13 - Circulation	
hallways (entrance foyer)	30
corridors	20
stairs	20
elevators	20
14 - Locker Rooms	
all types	20

NA = Not available. Task assumed not to be critical for acute viewing.
() = Area reference in IES Lighting Handbook

4-7.7 LIGHTING METHODS SUMMARY: Current standard methods of providing artificial lighting are shown in diagrammatic form. The lighting sub-system is conveniently grouped into the component categories of fixtures, lamps, shielding devices, controls, and special components. The methods shown are not necessarily recommended, and must be evaluated for specific intended uses.

4-7.7.1 Fixtures

- A. Direct (1), indirect (2) and semi-direct (3)

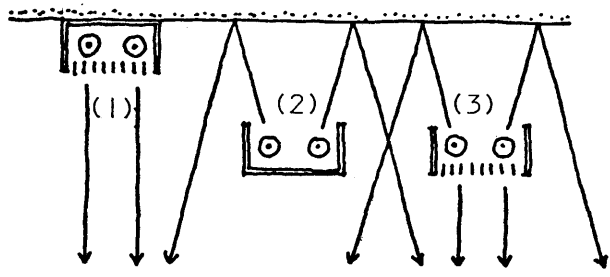

LIGHTING

B. Mounting: Recessed (1), semi-recessed (2), surface-mounted (3), pendant-mounted (4), integrated (5), semi-portable (6), portable (7), wall-mounted (8), etc.

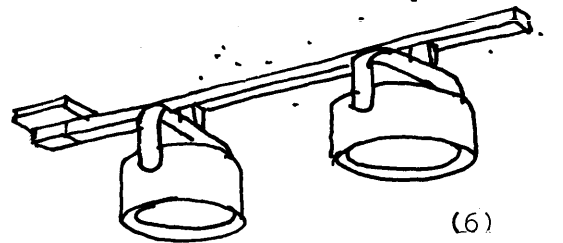
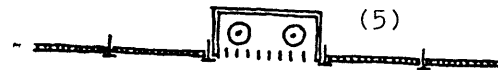
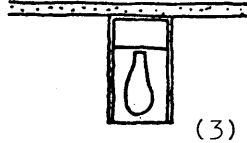
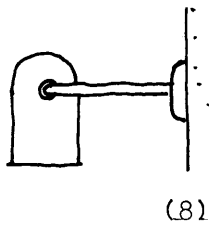
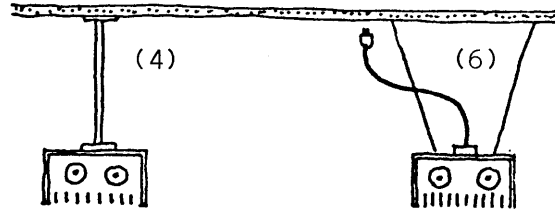
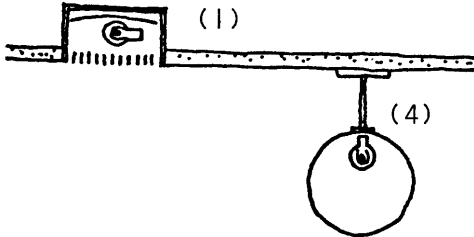
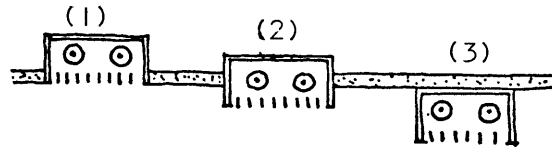

4-7.7.2 Lamps

	output	Color Rendition	Energy Use
Incandescent	25-500 W	Good	Poor
Fluorescent	430-1500 MA	Std. white, cool white & warm white.	Standard
Mercury Vapor	100-250 W	Deluxe white, clear, color improved.	Good
Tungsten-halogen	500 W	Poor	Effective

4-7.7.3 Shielding Devices

A. Louvers: A device that improves the cut-off angle characteristics and reduces glare. Materials are plastic or metal, used in a one-way or two-way configuration. (1)

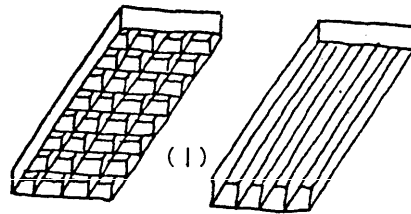

B. Diffusers: A device that lowers the surface brightness of the light source by spreading it over a greater area. Materials are frosted translucent glass or plastic. (2)

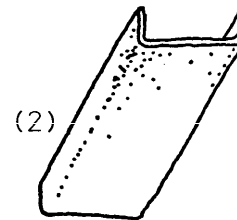

C. Lenses: A device that imprints some photometric pattern to the light. Materials are glass or plastic, and typical configurations are prismatic, ribbed, striated and polarized. (3)

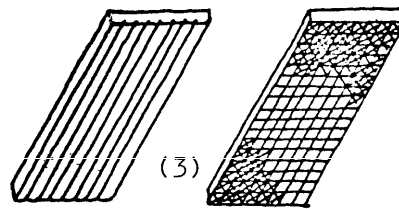

4-7.7.4 Controls

A. Circuiting: Direct, or low voltage.

B. Devices: One-way switch, three-way switch, zone switching, automatic switching, dimming.

4-7.7.5 Special Components

A. Air Diffuser: Light troffer units can be provided with integral air diffusers apertures. (4)

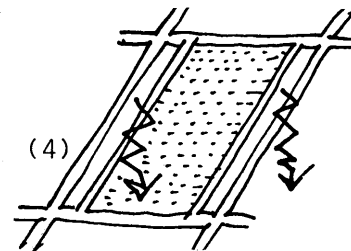

B. Non-corrosive Construction: Can be provided when required, e.g., kitchen.

LIGHTING

C. Special Lighting Requirements:
Color effect, food display
service in dining room.

4-7.7.6 Cost: The cost of decorative lighting can vary enormously, depending on the type of individual lighting fixtures used. The cost of fluorescent area lighting, for use in functional areas, varies predominantly with the desired intensity of illumination. The range of variation is indicated in Table 4-8.

Table 4-8 Lighting: Cost/Performance Summary

Lighting Level foot candles (lamps/100 s.f.)	Watts/s.f.	Initial High	Cost/s.f. Low	Operations* Cost/s.f./yr.
30 (2 lamps)	0.80-1.25	100	86	100
50 (4 lamps)	1.60-2.50	180	154	200
100 (8 lamps)	3.20-5.00	350	290	400
200 (16 lamps)	6.40-10.00	600	510	800

* Includes lamp replacement and energy usage.

5-1 THE PLANNING AND DESIGN PROCESS.

The translation of a space program into a design requires a series of planning and design decisions. This process is expressed in Tables 5-1 and 5-2.

5-2 THE STEPS IN THE PLANNING AND DESIGN PROCESS.

Each step, A, B, C, D, etc., involves the evaluation of a number of options. Examples of these options are shown in the table to indicate the level of decision-making at each step. As decisions are made they must be checked back with preceding steps to ensure that early decisions are not invalidated by later ones. The arrows shown in the chart adjoining PROCESS RECYCLE indicate this process. Finally, all decisions are conditioned by the basic parameter of cost as expressed in the quantity (the amount of space desired) and the quality (the standards of construction and finish).

5-3 SEQUENCE OF STEPS IN PLANNING AND DESIGN PROCESS.

The earlier steps, A through E, are performed in sequence. Later steps may be performed concurrently, or in no specific sequence, since the decisions are interrelated and their effect on one another must constantly be checked. Thus, floor plans and sections will be developed concurrently, and each may modify the other, as work proceeds. Planning Alternatives (STEP L) may be developed early in the process, before a definitive floor plan is developed.

Table 5-1

PLANNING AND DESIGN PROCESS

Planning Steps	Design										Design Development		
	A	B	C	D	E	F	G	H	I	J		K	L
Planning & Design Options	Space Program 1 Given	Affinity Matrix 1 Given	Affinity Diagram (no scale) 1 No Satellites 2 Satellite Bar 3 Satellite Entries 4 Satellite Kitchen 5 Satellite Dining	Affinity Diagram (to scale) 1 Program Areas	Planning Diagram 1 1-Story 2 2-Story 3 Linear Plan 4 2-Way Plan 5 3-Way Plan 6 Inward Looking 7 Outward Looking 8 Design Image 9 Orientating Site	Structural Framing 1 Bearing & Shear Wall 2 2-Way Rigid Frame 3 Cantilever Columns 4 Combination	Subsystem Choices 1 H.V.A.C. 2 Exterior Skin 3 Interior Partitions 4 Ceiling 5 Lighting 6 Miscellaneous	Floor Plan 1 Simple Plan 2 Fragmented Plan 3 Non-rectilinear	Section 1 Ceiling Heights 2 Roof Forms	Site Plan 1 Orientation 2 Entries 3 Parking 4 Pools	Design Analysis 1 Design & Review	Design Alternatives 1 General 2 Detail	Utility & Thermal Loads 1 Electrical Load 2 Water Usage 3 Sewage 4 Heating Load 5 Cooling Load
Process Recycle													
Conditioners	Cost Quantity Quality	Proximities		Climate Site Constraints									

Table 5-2 Explanation of Steps in the Planning and Design Process

A. SPACE PROGRAM	Development of the space program by the using serv ce initiates the planning process. (See Section 2-2.3)
B. AFFINITY MATR x	The affinity matrix indicates desirable relations p between spaces. These are established through review of the planning criteria and discussions with club operators and users.
c. AFFINITY DIAGRAM	A graphic expression of the affinity matrix. (not to scale)
D. AFFINITY DIAGRAM	A development of STEP C, in which the spaces are graphical ly repre- sented to scale, based on areas called for in the space program.
E. PLANNING DIAGRAM	A graphic representation of the proposed club plan, showing number of floors,basic planning principles, orientation, etc.
F. STRUCTURAL FRAMING	Selection of appropriate structural framing systems.
G. SUBSYSTEM CHOICES	A statement on proposed choice of subsystems.
H. FLOOR PLAN	Delineation of floor plan, showing accurate size of spaces, location of doors, windows, and general indication of service counters and work areas.
1. SECTIONS	Selected to show all necessary ceiling heights, and changes of floor level.
J. SITE PLAN	Indicates extent of site development, and delineates paved and land- scaped areas.
K. DESIGN ANALYSIS	Evaluation and commentary on major features of proposed plan.
L. DESIGN ALTERNATIVES	Delineation of significantly different functional design alternatives that can readily be accomplished.
M. UTILITY & THERMAL LOADS	Outline analysis of energy, and waste disposal requirements for the plan shown: ' useful for evaluating site needs and capability.

NOTE: ILLUSTRATIVE CRITERIA APPLICATIONS (SECTION 7) are expressed in a format that illustrate each of the steps shown above.

6-1.1 GENERAL CIRCULATION. Plan to preclude crossover traffic between club users and staff. Best solution is a similar circulation plan for users and service personnel with a mingling of the two at those places where their activities appropriately combine. (1)

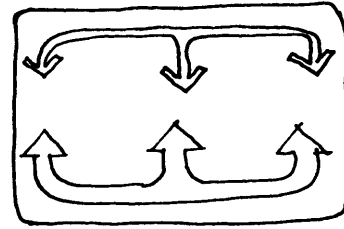

(1)

6-1.2 ENTRY PLANNING.

6-1.2.1 Plan for clear separation of main and service entries. (2)

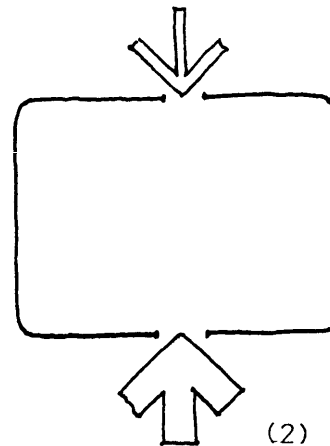

(2)

6-1.2.2 If main and service entry must be on same side of building, then site planning design elements must be used to achieve visual and functional separation. (3)

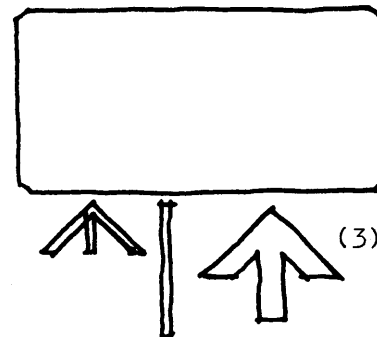

(3)

6-1.2.3 An additional entry that leads to an informal, bar or game room provides a natural separation between formal and informal users, who otherwise may conflict. (1)

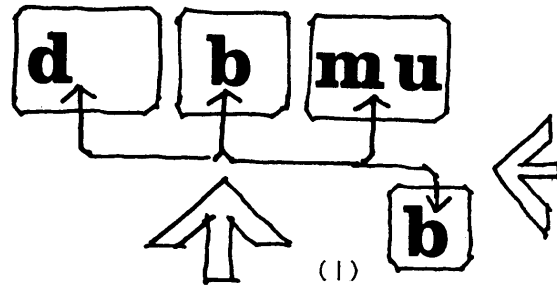

6-1.3 PARKING

6-1.3.1 Associate parking with users, with separate areas for staff and club members and guests. A large club should provide close parking for important members or guests, and parking location and quantity should reflect usage of activity areas. (2)

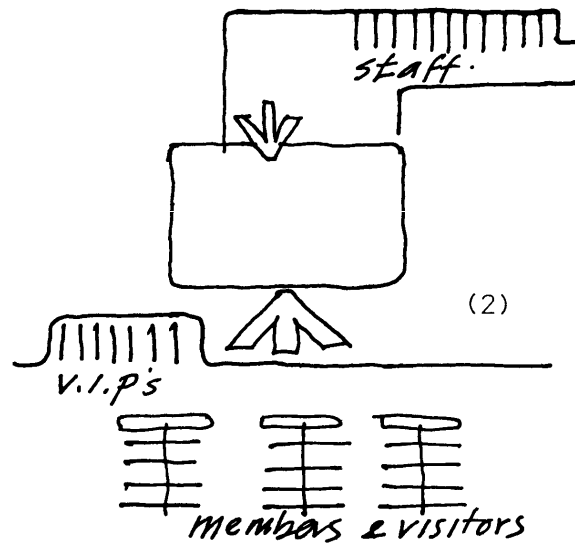

6-1.3.2 Do not approach club through sea of parking. If unavoidable, then screen parking from approach. (3)

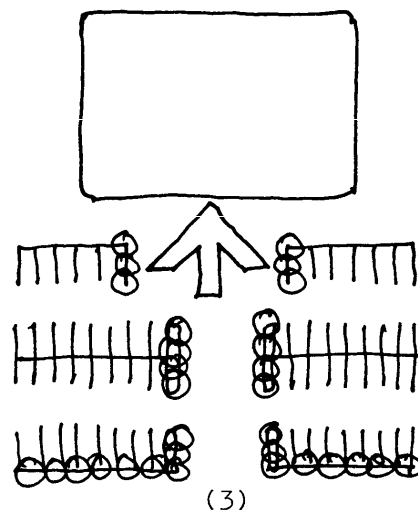

6-1.4 ENVIRONMENTAL PLANNING

6-1.4.1 When club surroundings are attractive, an outward-looking plan is appropriate.

6-1.4.2 If club surroundings are unattractive, then planning can create attractive interior views through use of landscaped courts. (1)

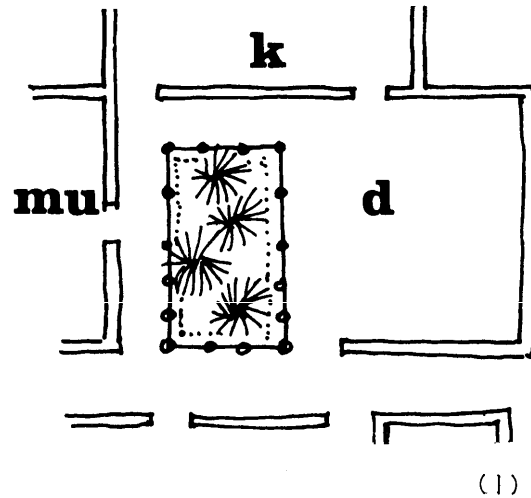

6-1.4.3 Alternatively, screened intimate landscaping can provide a pleasant outlook for perimeter rooms, even if surroundings are unpleasant. (2)

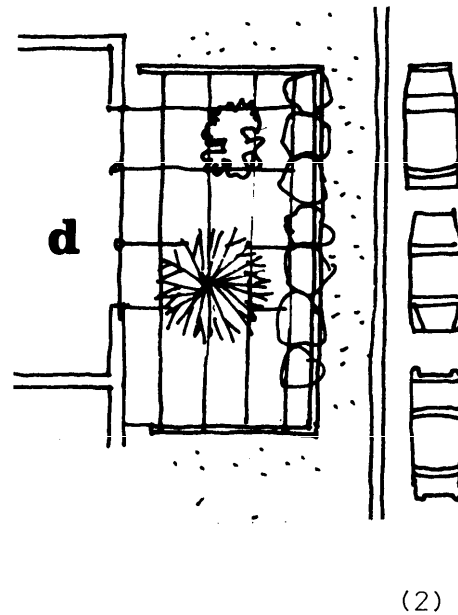

6-1.4.4 Size of plants should be sufficient to give immediate effect when planted.

6-1.4.5 Orient buildings to minimize solar loads in order to reduce energy consumption . Use eyebrows or other shading devices to reduce solar heat gain on glass that may face direct sunlight. (1)

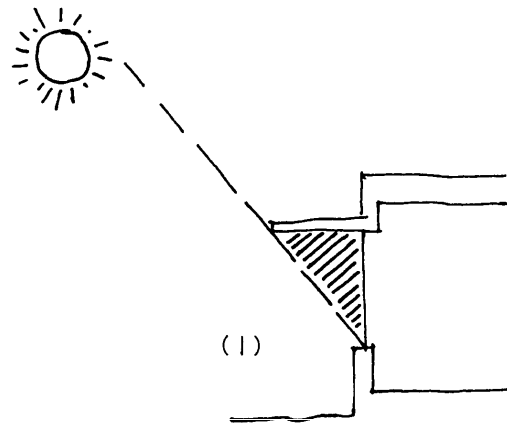

6-1.4.6 If there is an attractive view, the dining room and bar can most benefit from orientation towards it. However, sometimes view and orientation are in conflict. West orientation for a dining room is undesirable, because of glare from late-afternoon and evening sun. Often a compromise between orientation and view must be arrived at, based on detailed study of local conditions. (2)

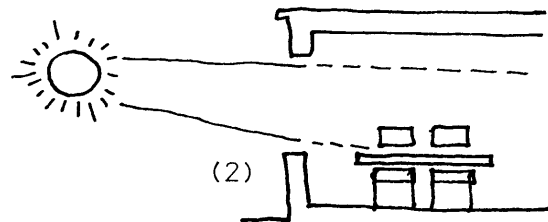

6-1.5 POOL PLANNING

6-1.5.1 Best location is adjoining the dining room, where patio food service can be provided. Should be exposed to southern sun, and screened from wind.

6-1.5.2 Location near club mechanical room is advantageous, so that pool heater and filtration equipment can be placed with other mechanical equipment.

6-1.5.3 Pool should have a separate entry from parking area, and also convenient entry to main club. (1)

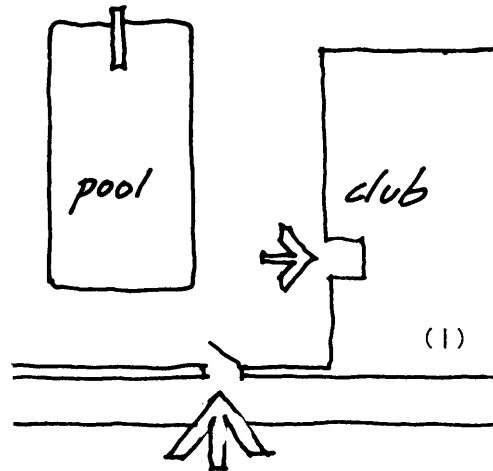

6-1.5.4 Pool location adjacent to both multi-use and dining rooms is difficult to arrange in one-story clubs. It is generally preferable to relate the pool to the dining room, with provision for snack service to a deck adjoining the pool. Typical activities in the multi-use room, such as bingo and dances, cannot utilize the pool facility. (2)

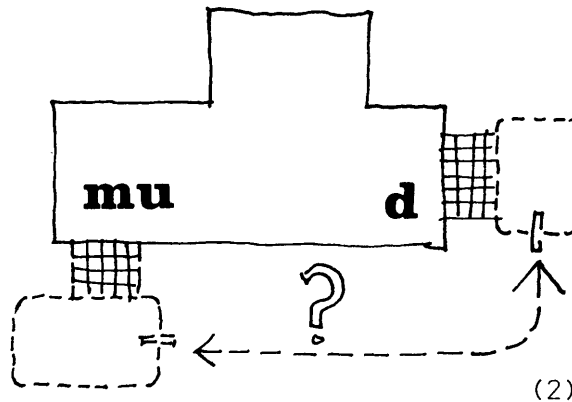

6-2.1 GENERAL PLAN ALTERNATIVES

6-2.1.1 The layout of the main activity areas--dining, bar and multi-use--and their intimate relationship to the kitchen--govern the planning of the club. Other areas, such as toilets, storage, etc. , are dependent on the layout of these main areas.

6-2.1.2 Of the main activity spaces-- multi-use, dining, and bar--the latter is most appropriately located adjacent to the entrance. In this location the bar can most conveniently fulfill its function as a socializing, meeting, and waiting space. In addition, a central location enables the bar conveniently to serve the dining, multi-use and party rooms without the need for separate service bars.

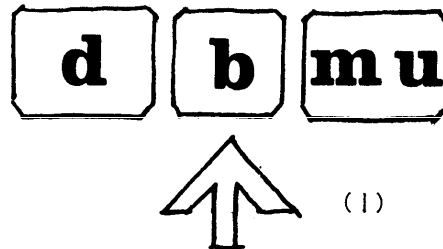

6-2.1.3 If the bar adjoins the entrance, there are three basic circulation arrangements that relate entry to the bar, multi-use and dining room, while providing good kitchen access to all three. These arrangements are:

- A. Linear: Multi-use, bar and dining room are arranged in line, with direct access to all. (2)

Good expansion for dining and multi-use

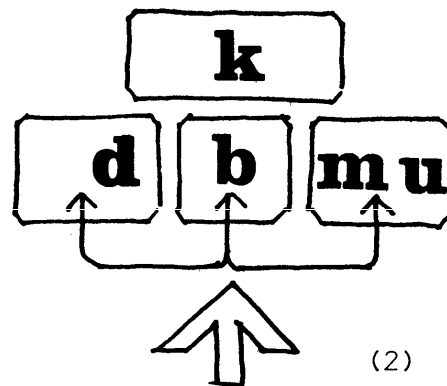

ARCHITECTURE

No flexibility between dining and multi-use.

This alternative linear plan of bar/dining/multi-use (1) provides good flexibility between dining and multi-use rooms.

Good expansion for bar, multi-use and kitchen.

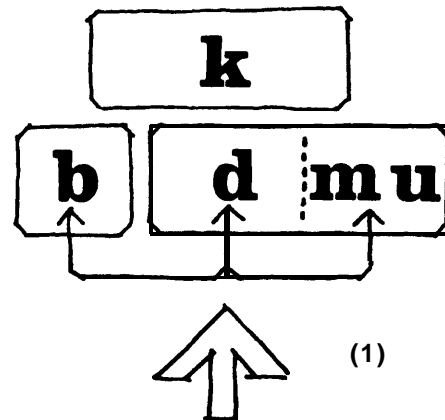

- B. Two-way: Dining room and multi-use access is separated by two sides of the bar. (2)

No flexibility between dining and multi-use room.

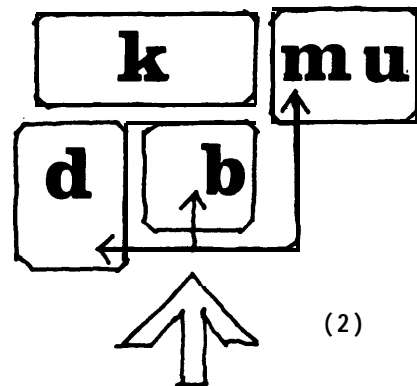

- C. Three-way: Dining room and multi-use access is separated by three sides of the

Provides good flexibility between dining room and multi-use rooms.

Good expansion for dining, multi-use, and kitchen.

Good separation of entrances to dining room and multi-use.

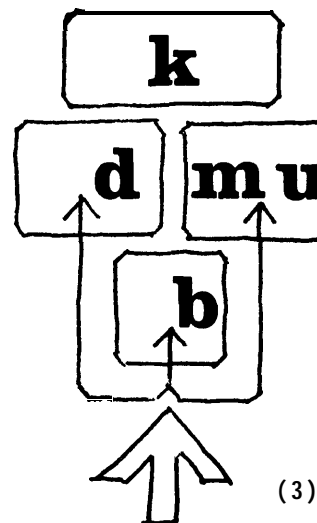

6-2.2 FLEXIBILITY

6-2.2.1 The ability to subdivide space by movable walls an impro space utilization.

6-2.2.2 It is unusual for all activities--bar, dining, banquet, party--to experience occupancy simultaneously.

6-2.2.3 Though flexibility saves overall space al location, it makes it more difficult to realize clear circulation routes for both users and staff. (1)

However, it is false economy not to provide such routes, and to rely on access through other activity spaces.

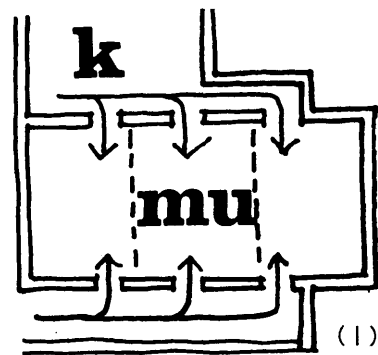

6-2.2.4 Flexible space is best planned as rectangular space with entries located on the long dimension. (2)

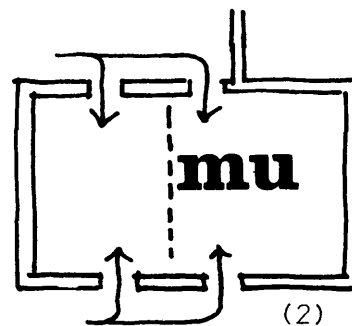

ARCHITECTURE

6-2.3 EXPANSION

6-2.3.1 If expansion can be foreseen with some certainty, spaces expected to expand should be programmed and a design developed in conjunction with a construction phasing plan. If expansion cannot specifically be foreseen, nevertheless consideration should be given to those areas most likely to expand. In general, these will be the multi-use space, the dining room, and the kitchen.

6-2.3.2 Space likely to expand should be located on the building perimeter. The bar will tend to be located in center of building, and can expand only by taking over space from adjoining functions (1), which in turn will need to expand.

6-2.3.3 Bar may best expand by addition of new bar, which may be of different character.

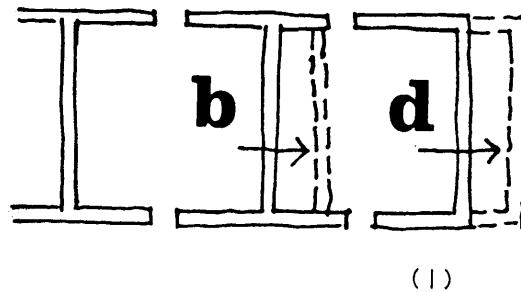

6-2.4 SECTION ALTERNATIVES

6-2.4.1 Single roof plane. Most economical construction for clubs where largest spaces do not exceed 30 ft. in width. When largest spaces exceed 30 ft. in width, ceiling height should exceed 10 ft. and small rooms should have dropped ceiling. Hence, not economical for large clubs due to excessive volume and furred space in small rooms. (2)

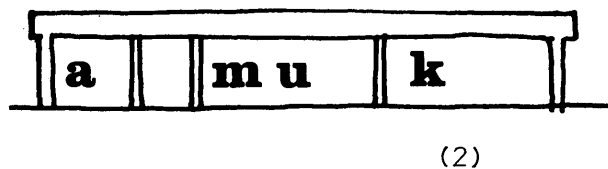

6-2.4.2 As an alternative to a single roof plane, it may be desirable to group low and high spaces together and to utilize two structural heights. (3)

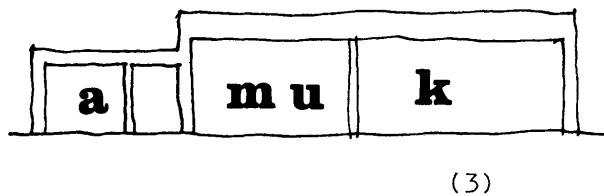

6-2.4.3 In large clubs provide varying ceiling and structural height to suit individual spaces. This approach should be limited to a maximum of three structural heights, or construction may become uneconomical. (1)

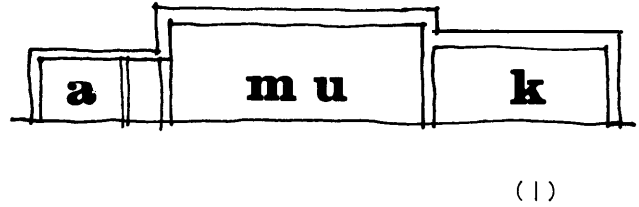

6-2.5 SECTIONS FOR SLOPING SITES

6-2.5.1 Flat roof plane, group large and small spaces to suit slope of land and reduce height of retaining walls. (2)

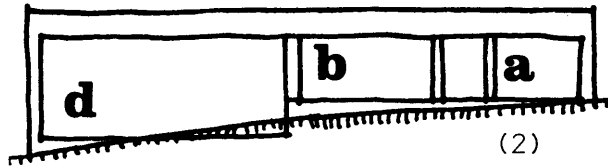

6-2.5.2 Step spaces to follow site, minimizing excavation and retaining walls. (3)

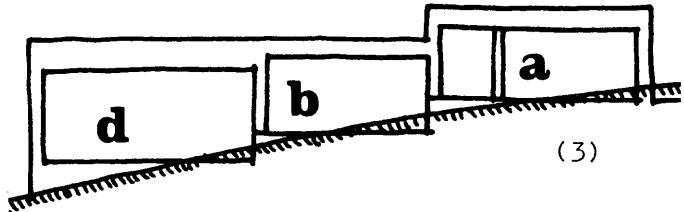

6-2.5.3 Use site to provide convenient two-level planning. (4)

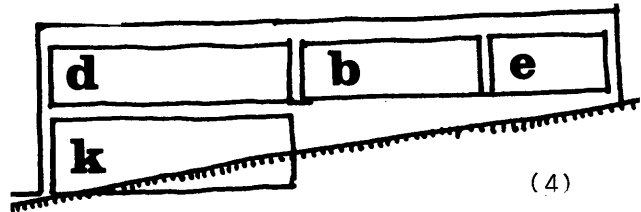

6-2.6 DESIGN IMAGE

6-2.6.1 Form of club building. Traditional buildings were narrow so that windows could provide light and ventilation to all spaces. Interior spaces, with no outside exposure, were not desirable. With the development of modern mechanical ventilation and cooling, comfortable interior spaces became possible.

ARCHITECTURE

Functional and economical planning tends to result in a characteristic form for a club building. This is a broad plan, sometimes approaching a square. This form of plan is only possible in conjunction with mechanical ventilation or air conditioning. By reducing extent of perimeter, such plans also reduce the heating and cooling loads. This is particularly true of the large single story club. (1)

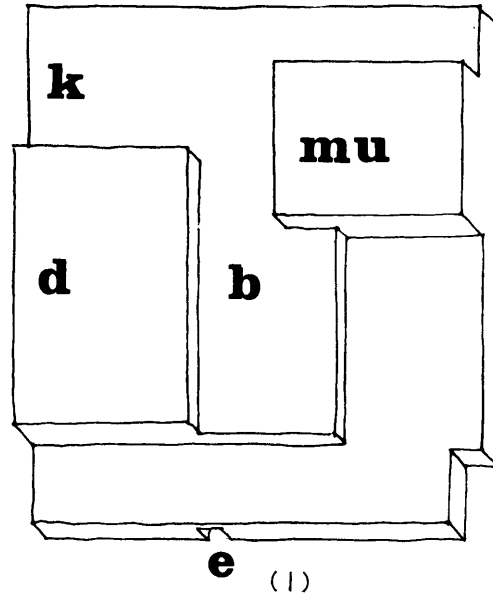

6-2.6.2 Design Expression.

The choice of design expression is a matter of taste and economics. In general, there is an appropriate expression for every economic level.

If the installation has a strong and attractive design image, or a consistent use of a particular building material, then this should be respected. Good manners in design wear well.

It is better to use an inexpensive material consistently well than to mix expensive and inexpensive materials badly. A well-designed stucco exterior will be more attractive than a combination of marble and aluminum shingles.

Buildings last a long time. If design follows current trends too closely, it may look foolish in ten years. Exteriors are more permanent than interiors and new design should recognize this. Exterior materials should be chosen that weather well and age gracefully.

6-2.6.3 Exterior Expression.
The exterior expression--style or appearance-- results from variations in four major design options. These are:

1. The building plan form
- B. The choice of exterior materials
- c. The roof shape
- D. The design details of each of the above, and the r overall effect in combinati on.

6-2.6.4 Building Plan Form.
Building plans can be classified as simple (1), fragmented (2), or non-rectangular (3).

(1)

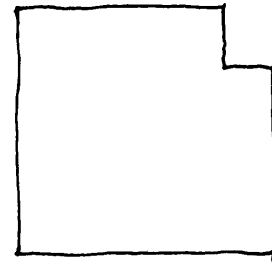

(2)

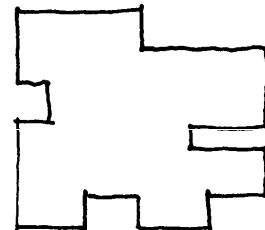

(3)

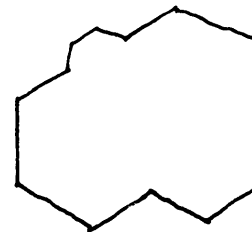

It should be noted that the geometry of the plan has a large effect on cost, irrespective of any other factors.

ARCHITECTURE

- A. Maximum Economy: Square plan (1)

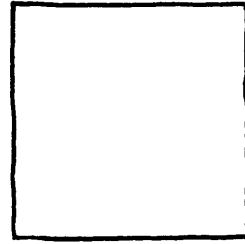

(1)

- B. Measure of economy is ratio:
Perimeter wall area/gross floor area. (2)

$$\text{Ratio} = \frac{2(ab + ac)}{bc}$$

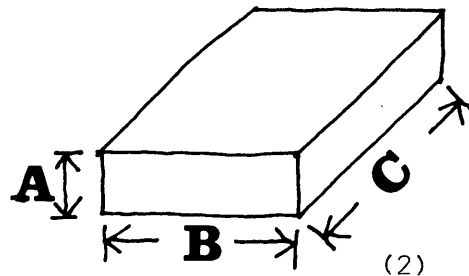

(2)

- C. Example 1: Perimeter wall area/gross floor area ratio = 0:4 @ \$5.00/s.f., exterior wall cost = \$20,000. (3)

Gross floor area = 10,000 s.f.
\$2.00/s.f. enclosed

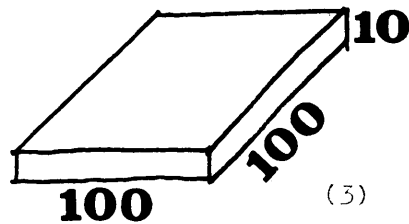

(3)

- D. Example 2: Perimeter wall area/gross floor area ratio = 0:64 @ \$5.00/s.f., exterior wall cost = \$32,000. (4)

Gross floor area = 10,000 s.f.
\$3.20/s.f. enclosed

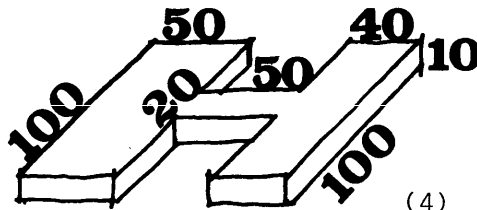

(4)

6-2.6.5 Choice of Exterior Materials. Materials should be selected both for their initial appearance and in recognition of their long-term weathering and maintenance qualities. Mixtures of a large number of different materials should be avoided, and the design should respect the nature of the materials so that frequent cutting or awkward shapes are avoided. This will improve appearance, and also be more economical .

6-2.6.6 The Roof Shape. The shape of the roof has a large effect on the design character. Common roof forms include flat, mansard, and a wide variety of sloping roofs.

6-2.6.7 Design Details. Detail design modifies the effect of basic design choices, and may add or detract from the overall intended effect.

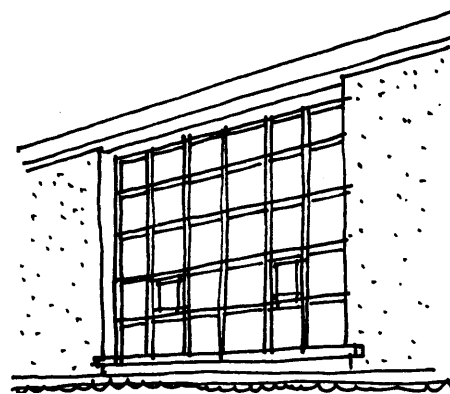
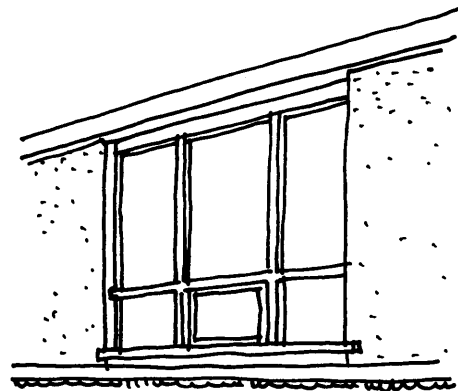

ARCHITECTURE

6-2.6.8 Combinations. The combination of the four major design options results in an almost infinite range of possible design images for a single functional plan. See Figure 6-1.

Figure 6-1 Range of Design Images for a Single Plan

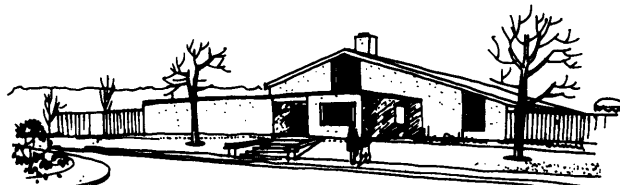
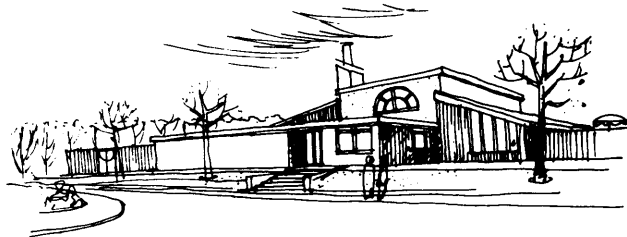
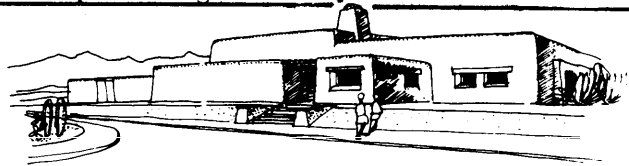

6-3.1 INTERIOR DESIGN REQUIREMENTS

6-3.1.1 General: Interior design features shall be developed in coordination with the architectural design. All features of the building relative to the interior design, whether they are furnished and installed as part of the construction contract or later provided by the using service, will be developed as an overall scheme. Graphic design and signage will be included as part of the overall design to identify activities with the using service and the installation.

6-3.1.2 Estimating: The costs of all items of equipment and furnishings which are permanently built-in or attached to the structure, as defined in AR 415-17, are normally considered part of the construction contract. Other items which are loose, portable or can be detached from the structure without tools, are generally provided by the using service under separate contract. Interior building surfaces, paint colors, floor coverings, window coverings as required, graphics and signage will be specified as part of the construction contract in coordination with the overall design. Furniture shall be identified for procurement by others.

6-3.1.3 Mandatory Sources: Sources for selection and procurement of furnishings are listed in the GSA Periodical Listing of National and Regional Federal Supply Schedules, the Federal Prison Industries Schedule of Products and the GSA Supply Catalog. Procurement by the using-service from these sources is mandatory insofar as the items covered meet requirements. For items not listed in the mandatory sources above, but which are part of the overall design scheme, appropriate guidance will be provided for procurement by the using service. Mandatory source schedules and catalogs must be reviewed carefully for their currency. New items will be found under New Item Introductory Schedule (NIIS) in the Periodical Listing, mentioned above.

6-3.1.4 Format: Drawings and schedules concerning items not included in the construction contract must be provided in a format that can be readily issued to and be understood by installation personnel who are responsible for procurement, and personnel who are responsible for component placement and utilization after delivery. Display sheets consisting of placement plans, catalog illustrations, material/color samples and perspective sketches of typical spaces; together with procurement lists, source data and cost estimates will be developed as appropriate to accomplish this objective. Clear coordination between these drawings and schedules, and the finish schedules under the construction contract must be evident.

INTERIOR

6-3.2 MATERIAL-COLOR SELECTION

6-3.2.1 General: Interior finishes shall be appropriate for the designed function of the building and spaces. Selection of materials should be based on low maintenance qualities considering the anticipated use, life cycle cost impact, fire and other safety requirements. Decisions concerning the extent of carpet installation will be coordinated with the using service and should be based on distinct functional advantages, such as acoustics or safety.

6-3.2.2 Color: Use of color in Army facilities is limited to a practical number selected from Federal Standard 595A; Colors. General guidance for color selection is provided in TM 5-807-7; Colors for Buildings. Use soft base colors (TM 5-807-7) in administrative areas and consider brighter base colors and accents in casual seeing spaces. In critical seeing areas, glare, brilliant colors and great brightness differences should be avoided.

6-3.2.3 Finish Materials: Finish materials must be selected in conjunction with color selection. The color, texture and pattern of materials should complement the overall design scheme and be in character with the desired image of the using and the installation/Command. Native (local) materials should be used to the greatest extent practicable. Long-life materials such as stones, tiles, woods, plastics, and vinyls should be selected to provide attractive colors, textures and patterns that will not quickly become out-dated. Painted surfaces and patterns are relatively easy and inexpensive to refinish and can be kept fresh and up-to-date in appearance.

6-3.2.4 Supergraphics: While mainly decorative, these graphics may frequently incorporate useful information such as floor and room numbers, or directional indicators. When professionally done, they can be most effective in livening up dead spaces and producing interest such as in large rooms or circulation spaces.

6-3.3 SIGNAGE AND GRAPHICS

6-3.3.1 General: Signage requirements will be specified as an overall signage system. Detail requirements of the using service will be coordinated at the local level. The system should assure maximum economy, ease of procurement and installation, and standardization of application throughout the club. It should also inhibit vandalism but be flexible enough to enable the addition or deletion of information.

6-3.3.2 Message Media: The use of wall graphics and symbols instead of words should be considered. Symbols cut down on the amount of signage required and they are easier to "read". For prohibition signs (such as No Smoking or No Entry), symbols cause less resentment or opposition than if the message had been in words. Letter sizes are designated by the height

of the capital letters. Typical uses are 1" for registers and general information signs, and 2" for directional and identification signs and any signs where background lines are 3" apart. Four inch lettering should be used where the background lines are 6" apart. Signs should be located as close to eye-level as possible and be illuminated to provide adequate comprehension, either by room lighting or by special sign lighting avoiding reflection and glare.

6-3.3.3 Facility Identifier Sign: A facility identification sign should be located in the entry area oriented toward exterior pedestrian traffic. The sign should identify the facility as "Officers Club" or "NCO Club." It may also indicate the hours of club operation. Size of lettering and the exact location of the sign should be determined in each individual case in relation to the architectural design.

6-3.3.4 Activity Locator Sign: A building activity locator sign should be provided in a prominent place in the entry area. The locator should identify and locate building spaces, key activities and personnel. Use of a graphic locator, perhaps a schematic building plan, should be considered for large facilities.

6-3.3.5 Pictographs or Symbol-signs: The simplest, most direct and economical way to convey certain forms of information is by the use of symbols or pictographs. Use sign panels, approximately 6" square, for most identification purposes on doors only (toilets, phones, house-keeping closets, stairs, etc.). Use sign panels approximately 12" square, for prohibitory signs (no entry, no smoking, etc.) and for Danger, Warning or Caution signs (electrical hazard, etc.). The locations of exits, fire protection and other safety equipment should be strongly emphasized as appropriate.

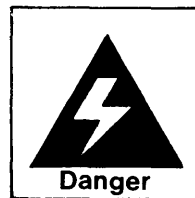

6-3.3.6 Identification Signs: When words and numbers are required as part of an individual space identification, use sign panels approximately 3" by 24" wall mounted, (next to doors on the side opposite the door swing). A letterform approximately 2" in height, black on white where numbers are required and white on black where words are required, is recommended. The number of 3" by 24" sign panels for each space will depend upon how much information must be displayed.



INTERIOR

6-3.3.7 Notice Boards: Notice boards help control clutter and can readily accommodate changing information. They should be used throughout the building wherever they will be most useful. A general notice board should be located in the entry of the club. Smaller boards may be located next to entrances to activity areas where there is a need to elaborate upon the type of activity inside, or to give the names of participants or staff involved, schedules, etc. Simple notice boards can be created by providing a 2' to 6' wide field of a solid base color surmounted at the 7' level by a 6" white board with the word "Notices" in 4" lettering. One or two narrow cork strips at the 6' and 4' levels should be provided as required for thumbtacking notices.

6-3.4 FURNITURE AND EQUIPMENT

6-3.4.1 General: Furniture and equipment will be selected from mandatory sources based upon the durability, comfort and safety required for the intended use. Furniture is an integral part of the overall design scheme, and will be closely coordinated with the selection of colors and finish materials for consistency in appearance and quality. Detailed requirements are covered in Section 3, Individual Space Criteria. Items that will be procured as part of the construction contract and those that will be procured by others must both be specified, (see paragraph 6-3.1).

6-3.4.2 Durability, Comfort and Safety: Careful attention must be given to all interior furnishings to insure that the type of furniture chosen conforms to standards of durability, comfort and safety appropriate for the use they will receive. Being generally mobile, furniture items are subject to handling. Parts that receive the most wear should be replaceable, and finishes should sustain regular cleaning. Colors, textures, sizes, proportions, shapes and reflections are important comfort factors that should be considered. Furniture and equipment must withstand loading conditions without damage. Edges and surfaces should be smooth and rounded. Materials must be flame-retardant.

6-3.4.3 Mobility and Interchangeability: Most interior furnishings should not be of a scale which would require more than two persons to relocate them, or be so complicated as to require an undue amount of time to assemble or disassemble. Whenever possible, care should be taken to choose multi-purpose furnishings aesthetically suitable for a variety of needs and activities. Stackable and foldable furniture should be considered for reducing bulkiness in storage and transport where such requirements exist.

Section 7. Illustrative Criteria Applications

7-1 GENERAL. The illustrative criteria applications in this section are for the following types and sizes of facilities.

<u>Example</u>	<u>Size</u> (gross floor area)
1 - Joint Club	15,649 s.f.
2 - Officers Club, Small	1,273
3 - Officers Club, Medium	7,806
4 - Officers Club, Large	25,494
5 - NCO Club, Small	9,217
6 - NCO Club, Medium	17,609
7 - NCO Club, Large	26,051

JOINT CLUB

7-2.1 STEP A - SPACE PROGRAM: The space program shown in Figure 7-1 provides for a single facility incorporating two functionally separate clubs sharing a common kitchen. Half of the program area for each generic space is provided for each' club (thus each, club has dining room of 13,053 s.f.). However, the kitchen and mechanical spaces are shared. The military strengths served are: Officers Club, 150-250; NCO Club, 401-750. Based on DOD 4270.1-M, a pool is provided for only the Officers' Club.

Figure 7-1 Space Program for Joint Club

<u>Generic Space</u>	<u>Program Area</u>	<u>% Gross Area</u>
1 - Entry	809	5.2
2 - Dining Room	2,106	13.4
3 - Bar	1,343	8.6
4 - Kitchen	3,383	21.6
5 - Multi-use	3,507.5	22.4
6 - Party Rooms		
7 - Recreation Room (Q)	643.5	4.1
8 - Recreation Room (N)		
9 - Administration	612.5	3.9
10 - Rest Rooms	661.5	4.2
11 - Storage	357	2.3
12 - Maintenance	24	.2
13 - Mechanical	637.5	4.1
14 - Lockers	(incorporated in staff restrooms)	
Net Usable	14,084.5	90
Gross Area	15,649	100
*Dining Room Occupancy:	75 @ 14 s.f./seat	
Multi-Use Occupancy:	116 - bingo	
	134 - banquet	
Net usable: gross area ratio:	0.90	

For basis upon which the space program is developed, see Sections 2 and 3.

7-2.2 STEP B - AFFINITY MATRIX: The affinity matrix shown in Figure 7-2 indicates relationships-between the generic spaces as being desirable (+), of no consequence (0), or undesirable (-). This is based upon use patterns, acoustic compatibility, mutual support for functional operation, sanitary or other reasons. The matrix is intended to denote the desirability of adjacency or separation per se, and along with the space program, is part of the problem statement generated by the using service.

Figure 7-2 Affinity Matrix for Joint Club

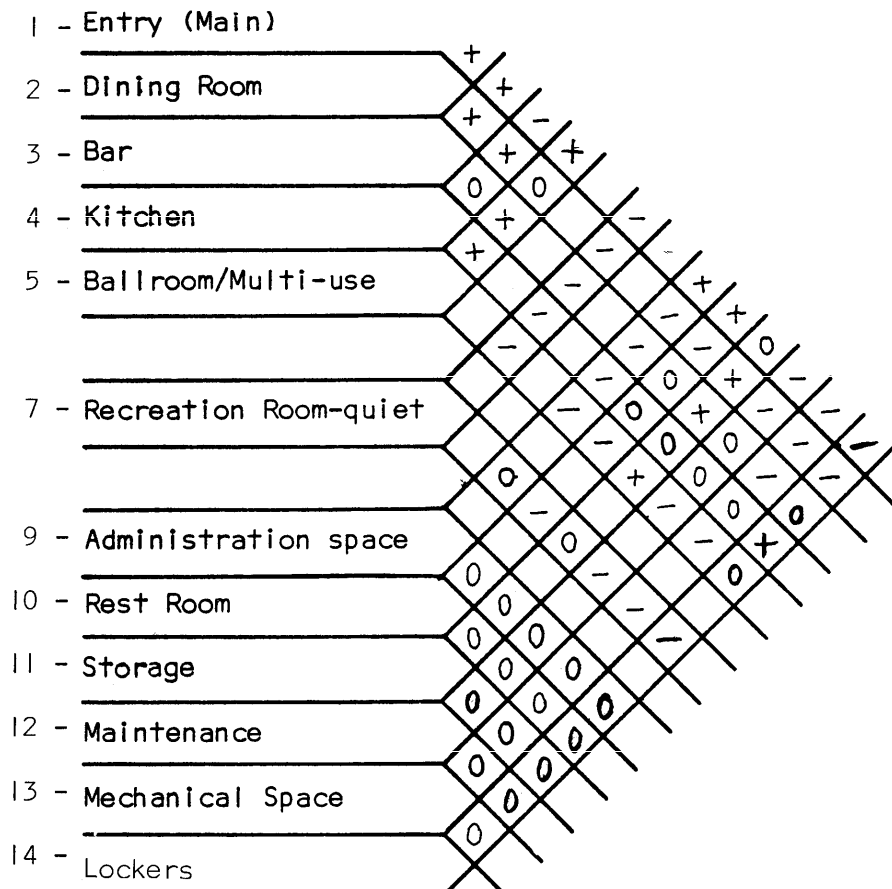

JOINT CLUB

7-2.3 STEP C - AFFINITY DIAGRAM (NO SCALE)

Figure 7-3 Affinity Diagram for Joint Club (no scale)

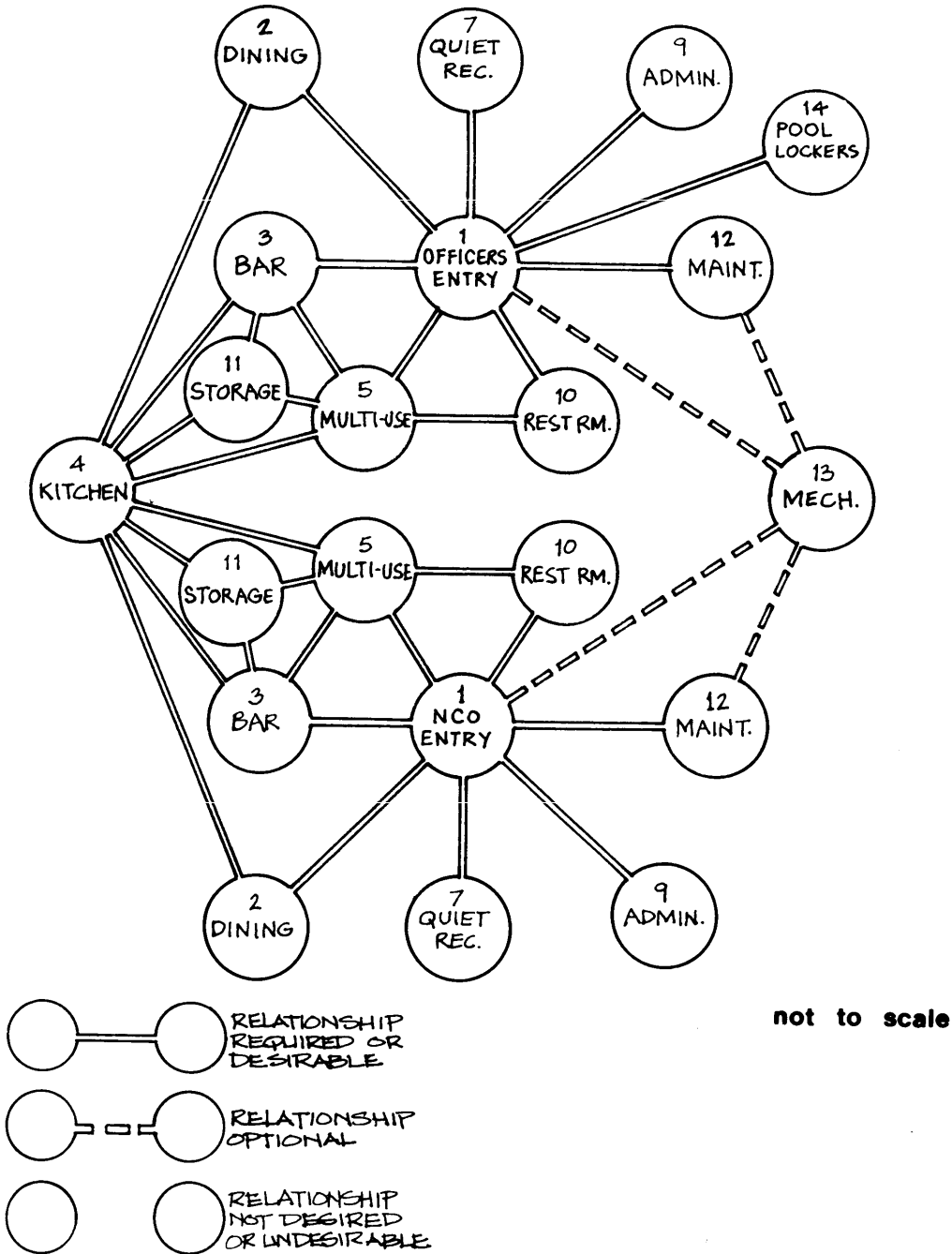

7-2.4 STEP D - AFFINITY DIAGRAM (TO SCALE)

Figure 7-4 Affinity Diagram for Joint Club (to scale)

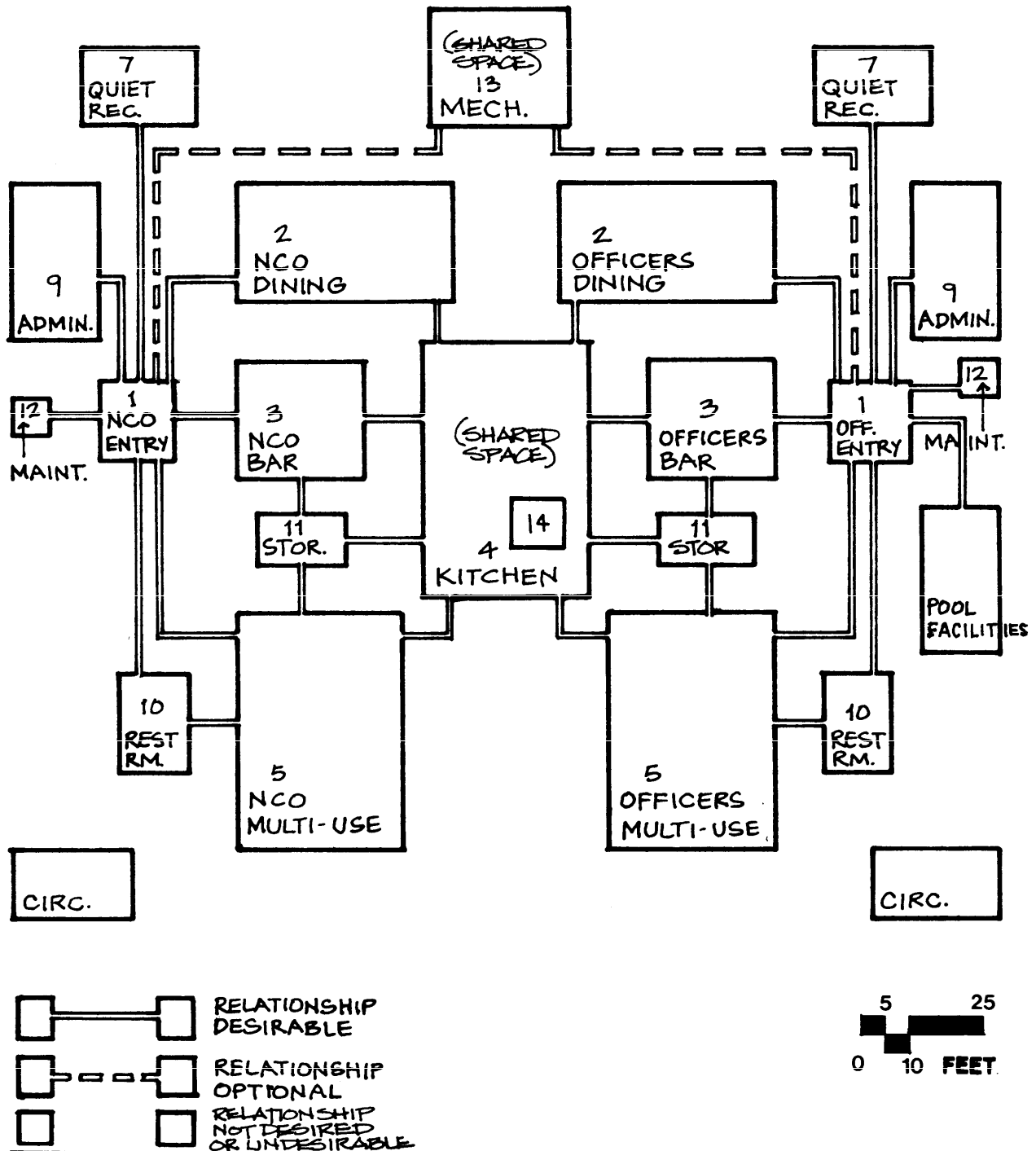

JOINT CLUB

7-2.5 STEP E - PLANNING DIAGRAM

Figure 7-5 Planning Diagram for Joint Club

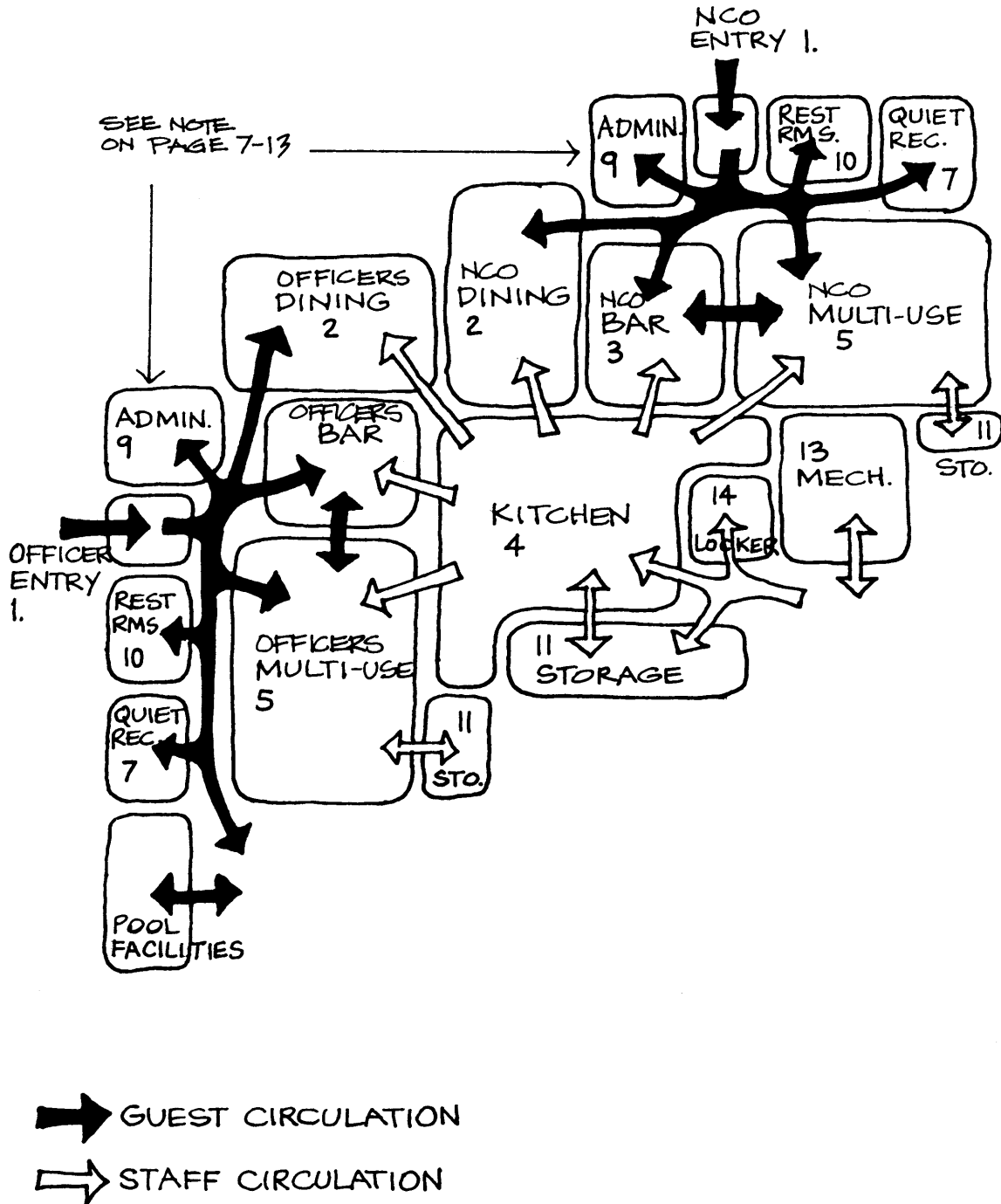

7-2.6 STEP F - STRUCTURAL FRAMING

7-2.6.1 Structure: Two-way rigid frame, chosen for maximum flexibility of interior space division.

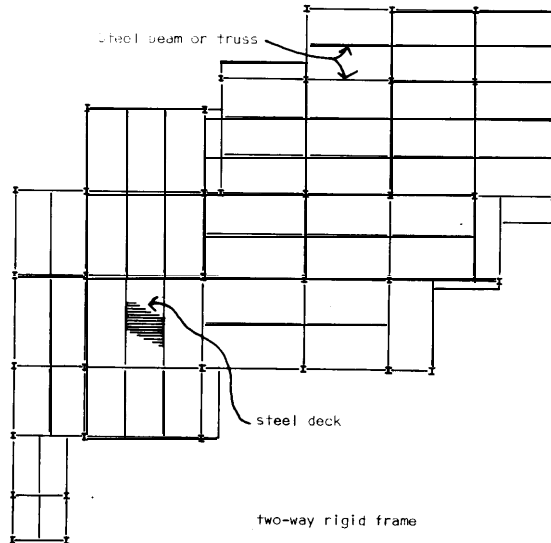

7-2.7 STEP G - SUBSYSTEM CHOICES

7-2.7.1 H.V.A.C.: System appropriate to climate. Separate systems for each club might be appropriate. Peak loads will tend to occur in both clubs simultaneously, so possibility of diversity is unlikely.

7-2.7.2 Envelope: Non-load bearing masonry or insulated panel, since structural frame carries all vertical loads.

7-2.7.3 Interior partitions: Non-load bearing replaceable partitions. Partition between officers and NCO dining room should provide high standard of sound separation. Operable walls in multi-use room.

7-2.7.4 Ceiling: Grid and panel type, suspended. Kitchen may use direct application to structure.

7-2.7.5 Lighting: Systems appropriate to design requirements.

JOINT CLUB

7-2.8 STEP H - FLOOR PLAN

Figure 7-6 Floor Plan for Joint Club

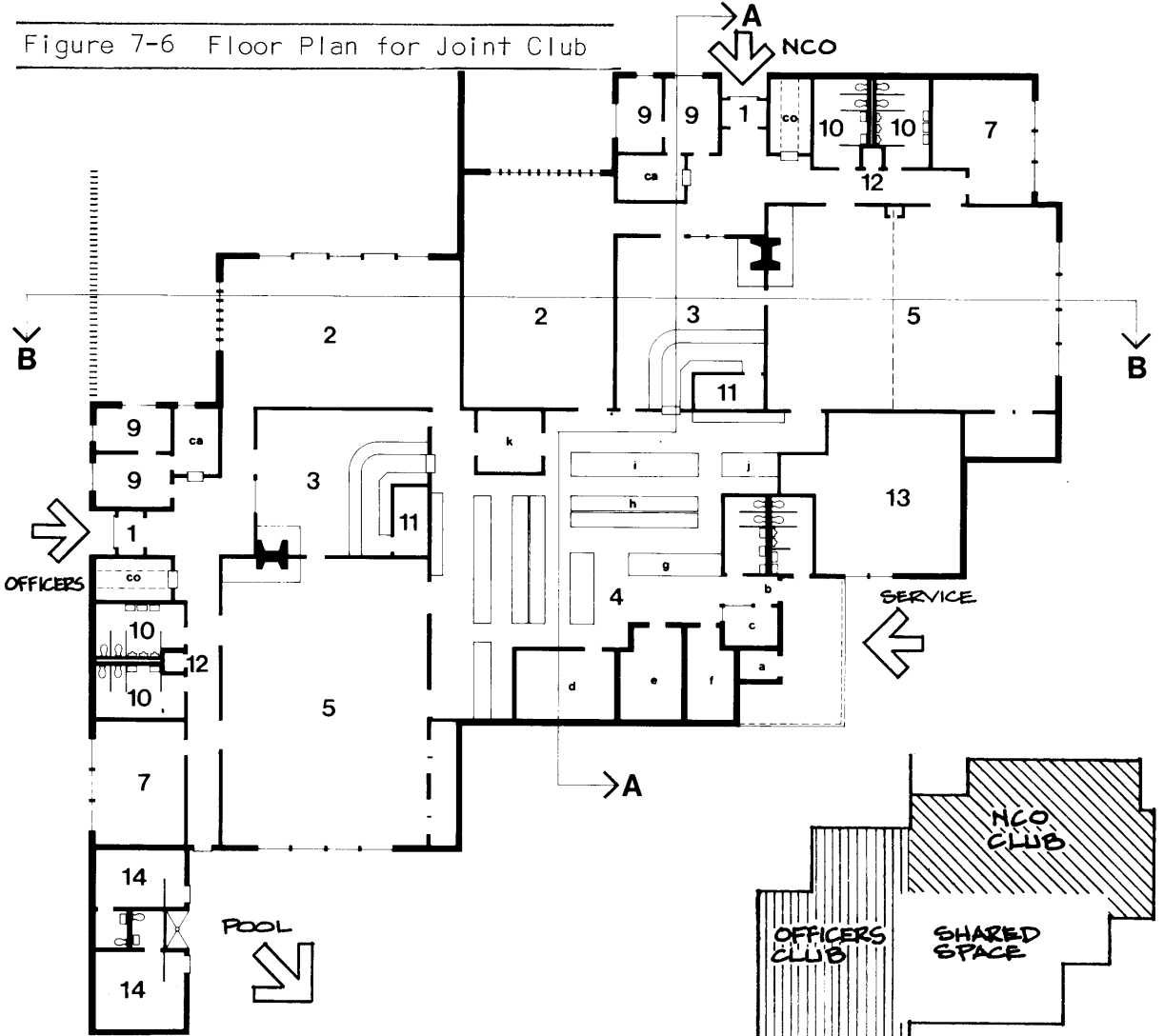

KEY

- | | |
|------------------------|----------------------|
| 1 entry | 5 ballroom/multi-use |
| co coatroom | 7 quiet recreation |
| 2 dining | 9 administration |
| 3 bar | ca cashier |
| 4 kitchen | 10 restrooms |
| a waste holding | 11 storage |
| b check-in | 12 maintenance |
| c chef's office | 13 mechanical |
| d dry storage | 14 locker room |
| e refrigerated storage | |
| f freezer storage | |
| g preparation area | |
| h cooking area | |
| i serving area | |
| j banquet make-up | |
| k dishwashing | |

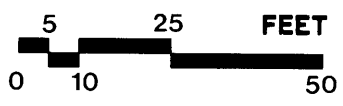

7-2.9 STEP 1 - SECTIONS

Figure 7-7 Sections for Joint Club

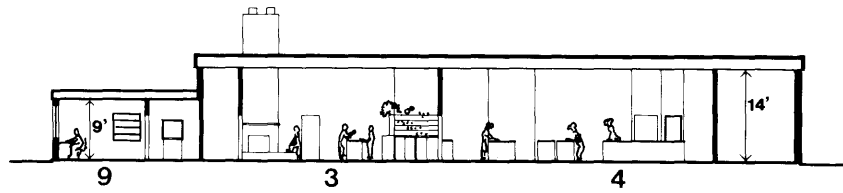

Section A - A

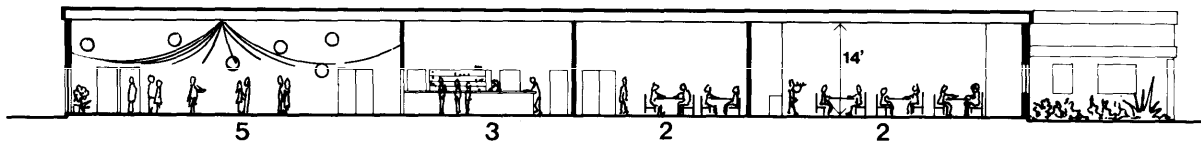

Section B - B



JOINT CLUB

7-2.10 STEP J - SITE PLAN

Figure 7-8 Site Plan for Joint Club

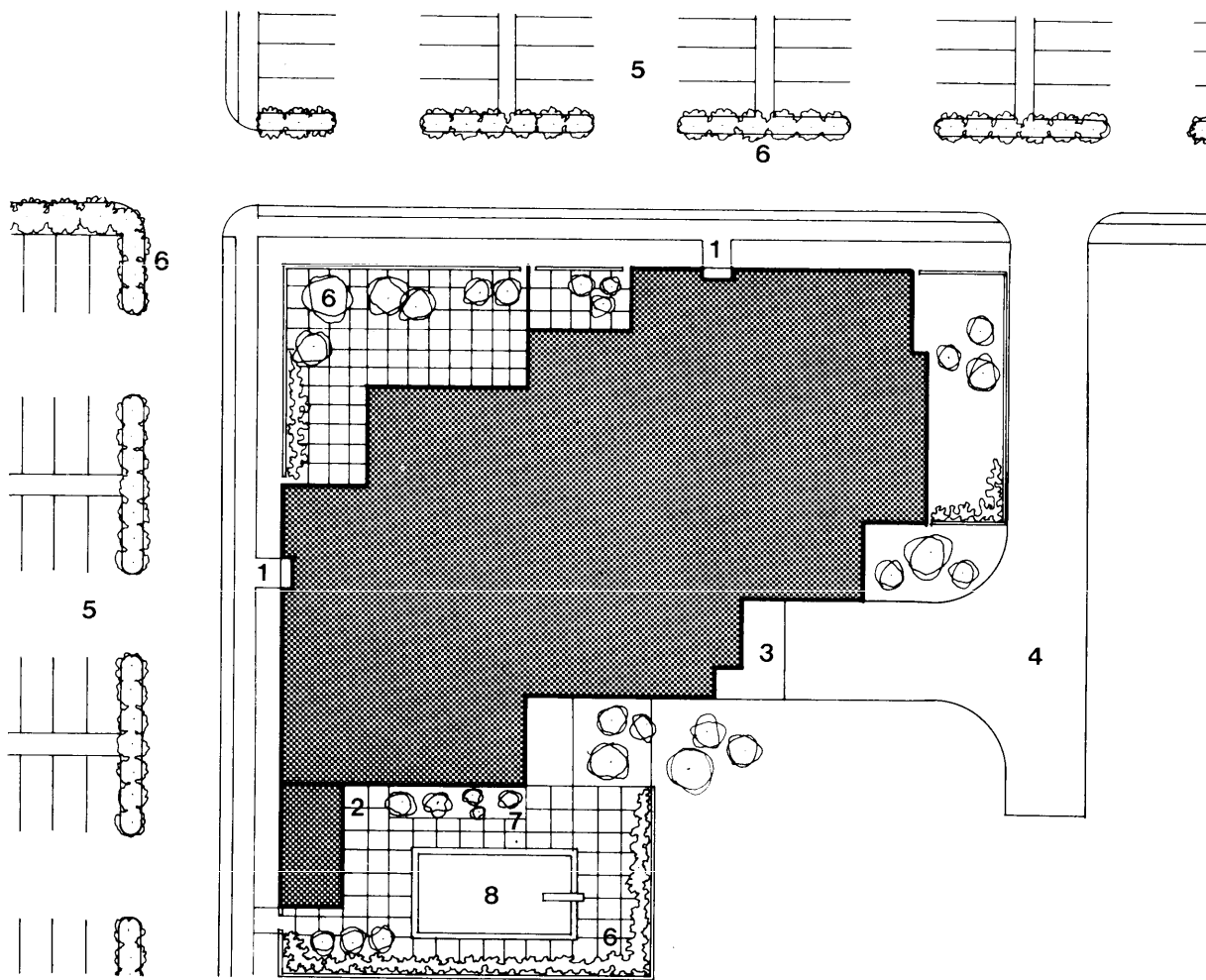

KEY

- 1 main entry
- 2 secondary entry
- 3 service entry
- 4 service access
- 5 parking
- 6 screen planting
- 7 intimate planting
- 8 officers pool

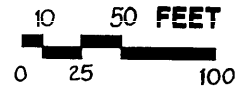

7-2.11 STEP K - DESIGN ANALYSIS

7-2.11.1 Plan type: Combination of two in-line plans.

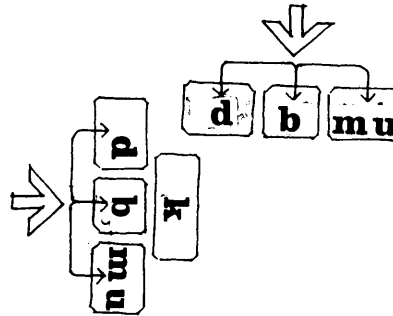

7-2.11.2 Design assumptions: No specific view or orientation.

7-2.11.3 Planning objectives: Building. Provide for complete separation between officers and NCO's within the club.

7-2.11.4 Planning evaluation: Building.

- A. Good separation between officers and NCO's.
- B. Two dining rooms well located for service, yet separation preserved.

7-2.11.5 Planning objectives: Site. Provide separate entries and parking to officers' and NCOs' clubs.

7-2.12 STEP L - PLANNING ALTERNATIVES

7-2.12.1 Administration space: The example floor plan for this facility shows separate administration areas for this officers and NCO club. Construction economies, and possibly also operating economies, can be realized if these spaces are consolidated into one administration area serving the two clubs. However, such an arrangement is dependent upon a management decision that places the clubs under a single management.

7-2.12.2 Storage: Additional economy may be achieved by providing a central storage area serving both clubs.

JOINT CLUB

7-2.13 STEP M - UTILITY & THERMAL LOADS

7-2.13.1 Building data

A. Gross floor area	15,649 s.f.
B. Max. population at one time	550
C. Max. meals served/day	800

7-2.13.2 Utility loads

A. Electrical: Light and power	465 kva
B. Water: Max. flow rate, cold water	96 gpm
Max. flow rate, hot water	96 gpm
Total flow per day	8,000 gal.
C. Sewage: Total gallons per day	8,000 gal.

7-2.13.3 Heating and cooling loads

A. Heating: Load	463 MBTU/hr.
B. Air conditioning: Tons of refrigeration	59 tons

7-2.13.4 Design assumptions

All policy and design criteria per DOD 4270.1-M.

- A. Estimates are for plans shown.
- B. 40° North latitude.
- C. Heat load in kitchen not included in heat gain calculations.
- D. Mechanical room ventilated only.
- E. Single glazing, standard glass.
- F. 20% outside air assumed for ventilation
- G. Assumed perimeter heat loss: 40 BTU/hr./ft.
- H. Sewage demand based on 10 gpd per person, max. occupancy.
- I. Lighting load assumed 2.5 watts/s.f.

7-3.1 STEP A - SPACE PROGRAM: The space program shown in Figure 7-9 provides a club that is planned as a single space-arranged as a cafe and cocktail bar. Such a facility might be an annex to a main club, or be provided on a small installation, and would probably be remodeled from available existing space. With these assumptions, planning design process steps C, D, E, F, and G do not apply, and are omitted. The military strength served is 29 officers.

Figure 7-9 Space Program for Small Officers Club

Generic Space	Program Area	% Gross Area
1 - Entry	56.5	4.4
2 - Dining Room	474.5	37.3
3 - Bar	300	23.6
4 - Kitchen	216	16.9
5 - Multi-use	---	---
6 - Party Rooms	---	---
7 - Rec. Room (Q)	---	---
8 - Rec. Room (N)	---	---
9 - Administration	---	---
10 - Rest Rooms	88	7
11 - Storage	10	.8
12 - Maintenance	---	---
13 - Mechanical	---	---
14 - Lockers	---	---
Net Usable	1,145	90
Gross Area	1,276	100

Dining Room Occupancy: 34 @ 14 s.f./seat

Net usable: gross area ratio: 0.90

For basis upon which this space program is developed, see Sections 2 and 3.

SMALL OFFICERS CLUB

7-3.2 STEP B - AFFINITY MATRIX: The affinity matrix shown in Figure 7-10 indicates relationships between the generic spaces as being desirable (+), of no consequence (0), or undesirable (-). This is based upon use patterns, acoustic compatibility, mutual support for functional operation, sanitary or other reasons. The matrix is intended to denote the desirability of adjacency or separation per se, and along with the space program, is part of the problem statement generated by the using service.

Figure 7-10 Affinity Matrix for Small Officers Club

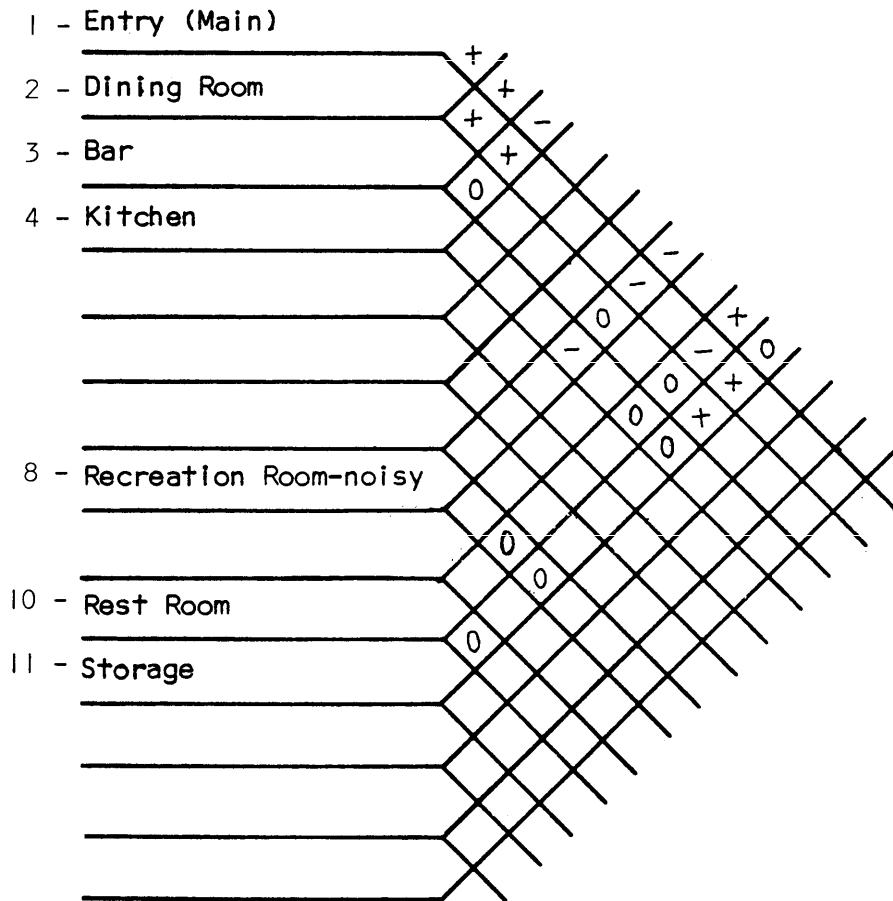

7-3.3 STEP H - FLOOR PLAN

Figure 7-11 Floor Plan for Small Officers Club

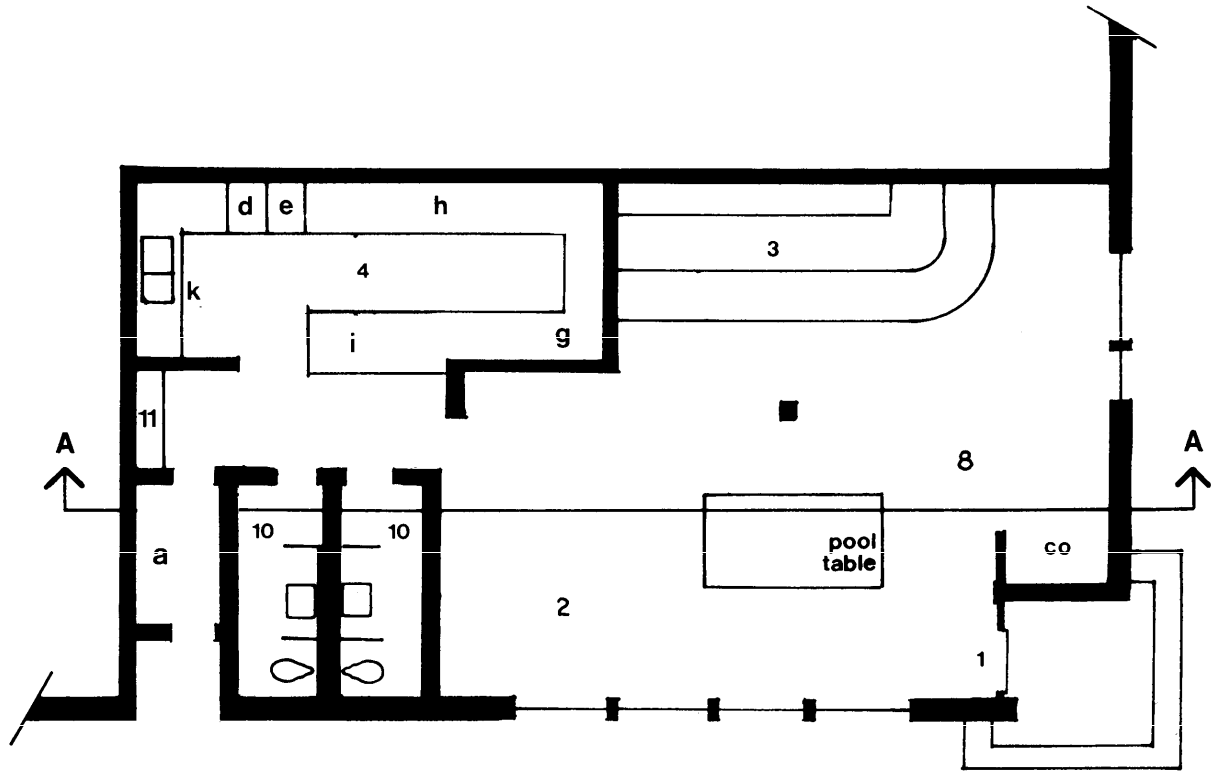

KEY

- 1 entry
- co coatroom
- 2 dining
- 3 bar
- 4 kitchen
 - a waste holding
 - d dry storage
 - e refrigerated storage
 - g preparation area
 - h cooking area
 - i serving area
 - k dishwashing
- 8 noisy recreation
- 10 restrooms
- 11 storage

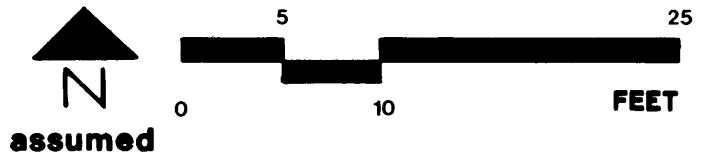

SMALL OFFICERS CLUB

7-3.4 STEP 1 - SECTION

Figure 7-12 Section for Small Officers Club

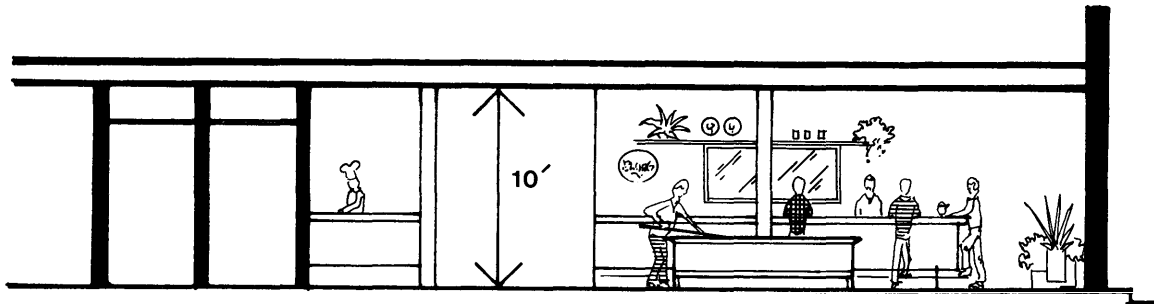

Section A - A

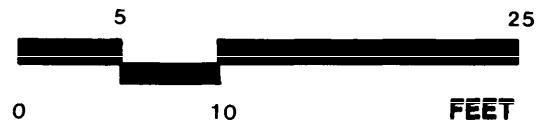

7-3.5 STEP J - SITE PLAN

Figure 7-13 Site Plan for Small Officers Club

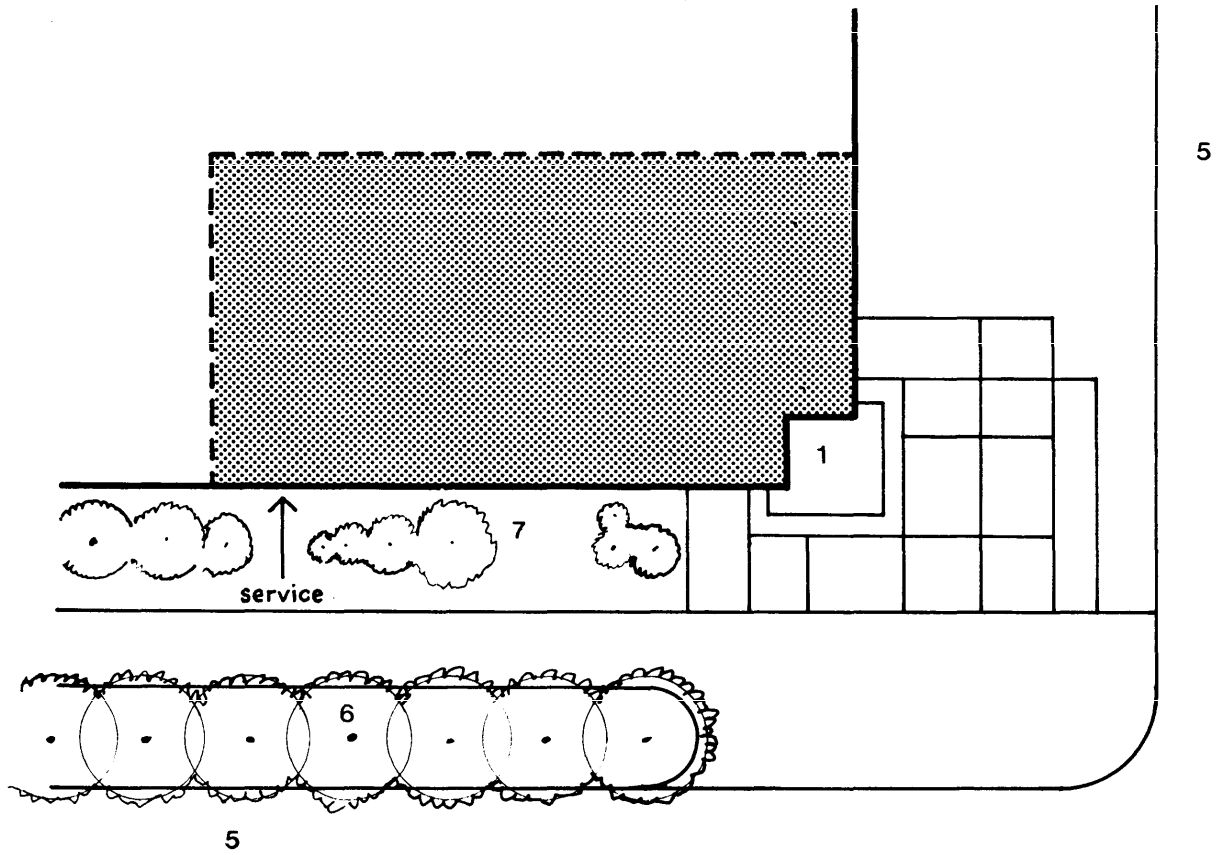

KEY

- 1 main entry
- 5 parking
- 6 screen planting
- 7 intimate planting

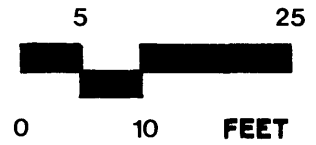

SMALL OFFICERS CLUB

7-3.6 STEP K - DESIGN ANALYSIS

7-3.6.1 Plan type: single space, remodel.

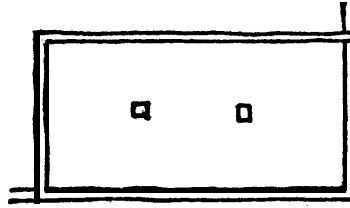

7-3.6.2 Design assumptions

- A. Remodel existing building.
- B. Accept existing structure.
- C. Corner location.

7-3.6.3 Planning objectives:
Building.

- A. Maximum utilization of space.
- B. Aim for atmosphere of traditional San Francisco or New Orleans style single room bar/cafe.

7-3.6.4 Planning evaluation:
Building.

- A. Single multi-use open space maximizes space utilization.
- B. Existing structure accommodated without deterrent to function.
- C. Good possibility for attractive atmosphere.

7-3.7 STEP L - PLANNING ALTERNATIVES

Figure 7-14 Alternative 1 for Small Officers Club

Objective: Club designed as free standing structure.

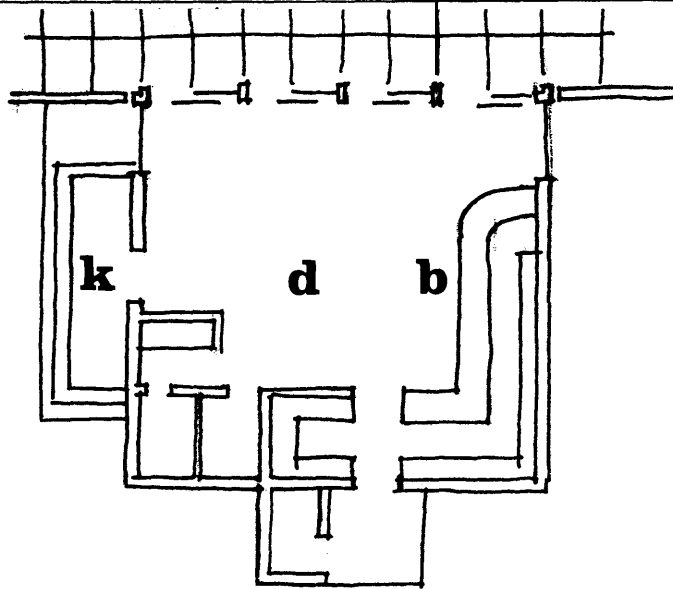
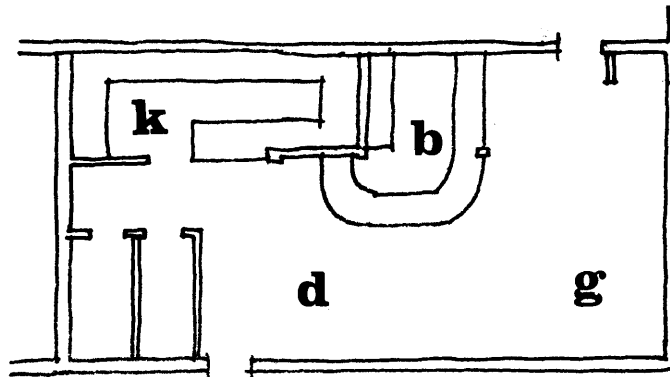

Figure 7-15 Alternative 2 for Small Officers Club

Objective: Club with entry from existing building and from street.



SMALL OFFICERS CLUB

7-3.8 STEP M - UTILITY & THERMAL LOADS

7-3.8.1 Building data

A. Gross floor area	1,273 s.f.
B. Max. population at one time	52
C. Max. meals served/day	100

7-3.8.2 Utility loads

A. Electrical : Light and power	49 kva
B. Water: Max. flow rate, cold water	32 gpm
Max. flow rate, hot water	32 gpm
Total flow per day	1,000 gal.
C. Sewage: Total gallons per day	1,000 gal.

7-3.8.3 Heating and cooling loads

A. Heating: Load	40 MBTU/hr.
B. Air conditioning: Tons of refrigeration	5.75 tons

7-3.8.4 Design assumptions

All policy and design criteria per DOD 4270.1-M.

- A. Estimates are for plans shown.
- B. 40° North latitude
- C. Heat load in kitchen not included in heat gain calculations.
- D. Single glazing, standard glass.
- E. 20% outside air assumed for ventilation
- F. Assumed perimeter heat loss: 40 BTU/hr./ft.
- G. Sewage demand based on 10 gpd per person, max. occupancy.
- H. Lighting load assumed 2.5 watts/s.f.

7-4 MEDIUM OFFICERS CLUB

7-4.1 STEP A - SPACE PROGRAM: The space program shown in Figure 7-16 is based on a need to seat 75 for dining, plus simultaneous banquet facilities in a flexible multi-use room that provides for all meeting and party functions. The military strength served is 151-250 officers.

Figure 7-16 Space Program for Medium Officers Club

Generic Space	Program Area	\$ Gross Area
1 - Entry	318	4.1
2 - Dining Room	1,045.5	13.4
3 - Bar	659.5	8.4
4 - Kitchen	1,557	20
5 - Multi-use	1,775	22.7
6 - Party Rooms	---	---
7 - Rec. Room (Q)	---	---
8 - Rec. Room (N)	---	---
9 - Administration	309	3.9
10 - Rest Rooms	235	3
11 - Storage	252	3.2
12 - Maintenance	12	.2
13 - Mechanical	333	4.3
14 - Lockers	529	6.8
Net Usable	7,025	90
Gross Area	7,806	100
Dining Room Occupancy:	74 @ 14 sq. ft./seat	
Ballroom Occupancy:	120 - bingo	
	138 - banquet	
Net usable: gross area ratio:	0.90	

For basis upon which this space program is developed, see Sections 2 and 3.

MEDIUM OFFICERS CLUB

7-4.2 STEP B - AFFINITY MATRIX: The affinity matrix shown in Figure 7-17 indicates relationships between the generic spaces as being desirable (=), of no consequence (0), or undesirable (-). This is based upon use patterns, acoustic compatibility, mutual support for functional operation, sanitary or other reasons. The matrix is intended to denote the desirability of adjacency or separation per se, and along with the space program, is part of the problem statement generated by the using service.

Figure 7-17 Affinity Matrix for Medium Officers Club

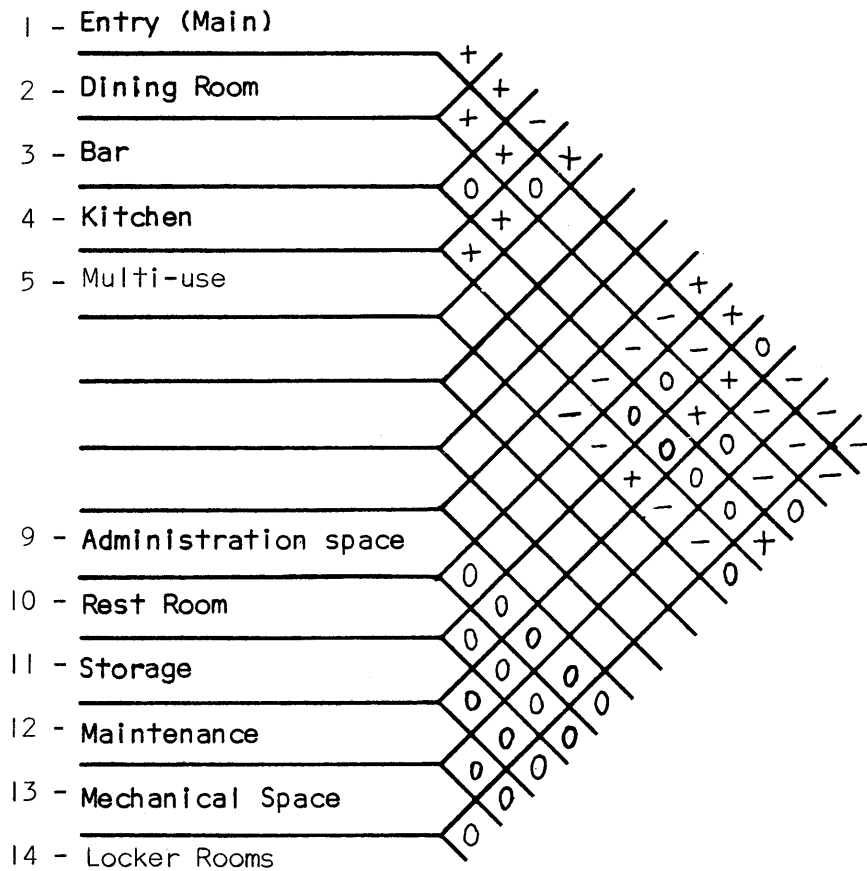

7-4.3 STEP C - AFFINITY DIAGRAM (NO SCALE)

Figure 7-18 Affinity Diagram for Medium Officers Club (no scale)

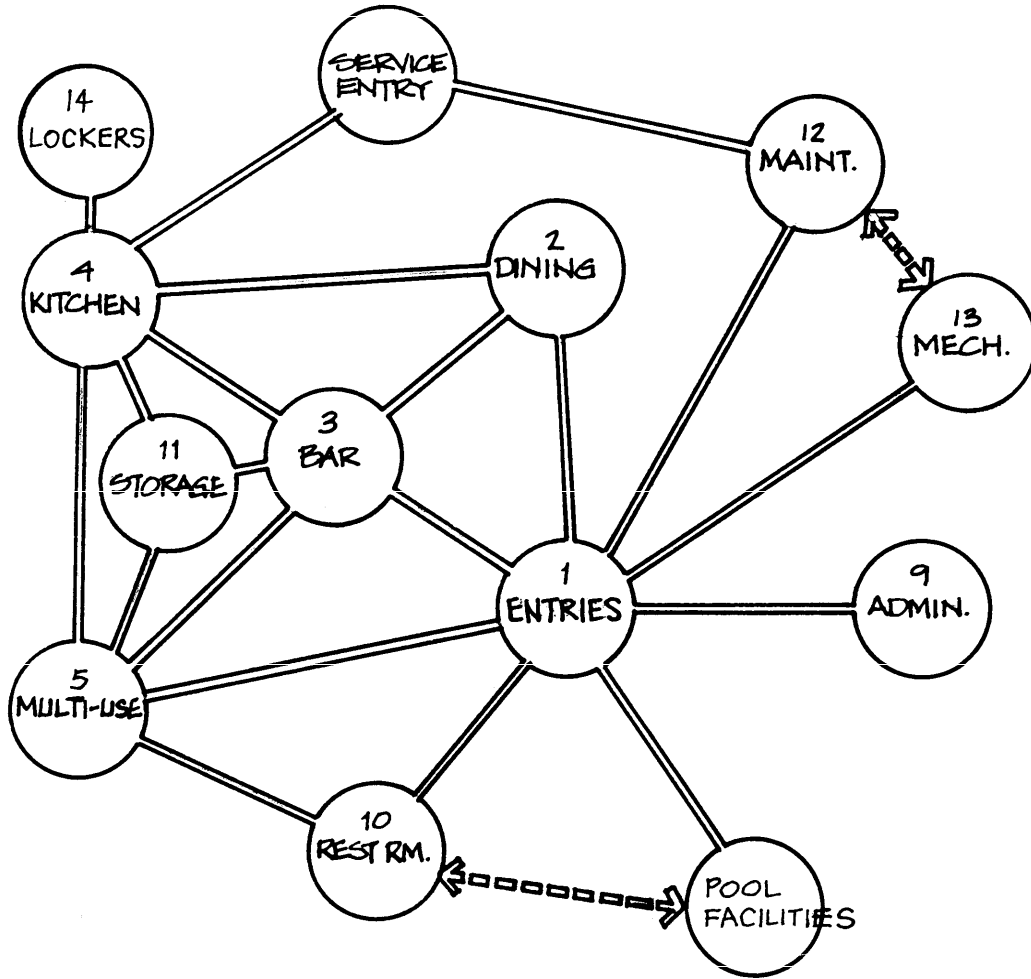

not to scale



7-4.5 STEP E - PLANNING DIAGRAM

Figure 7-20 Planning Diagram for Medium Officers Club

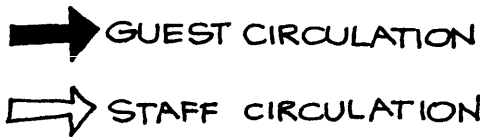
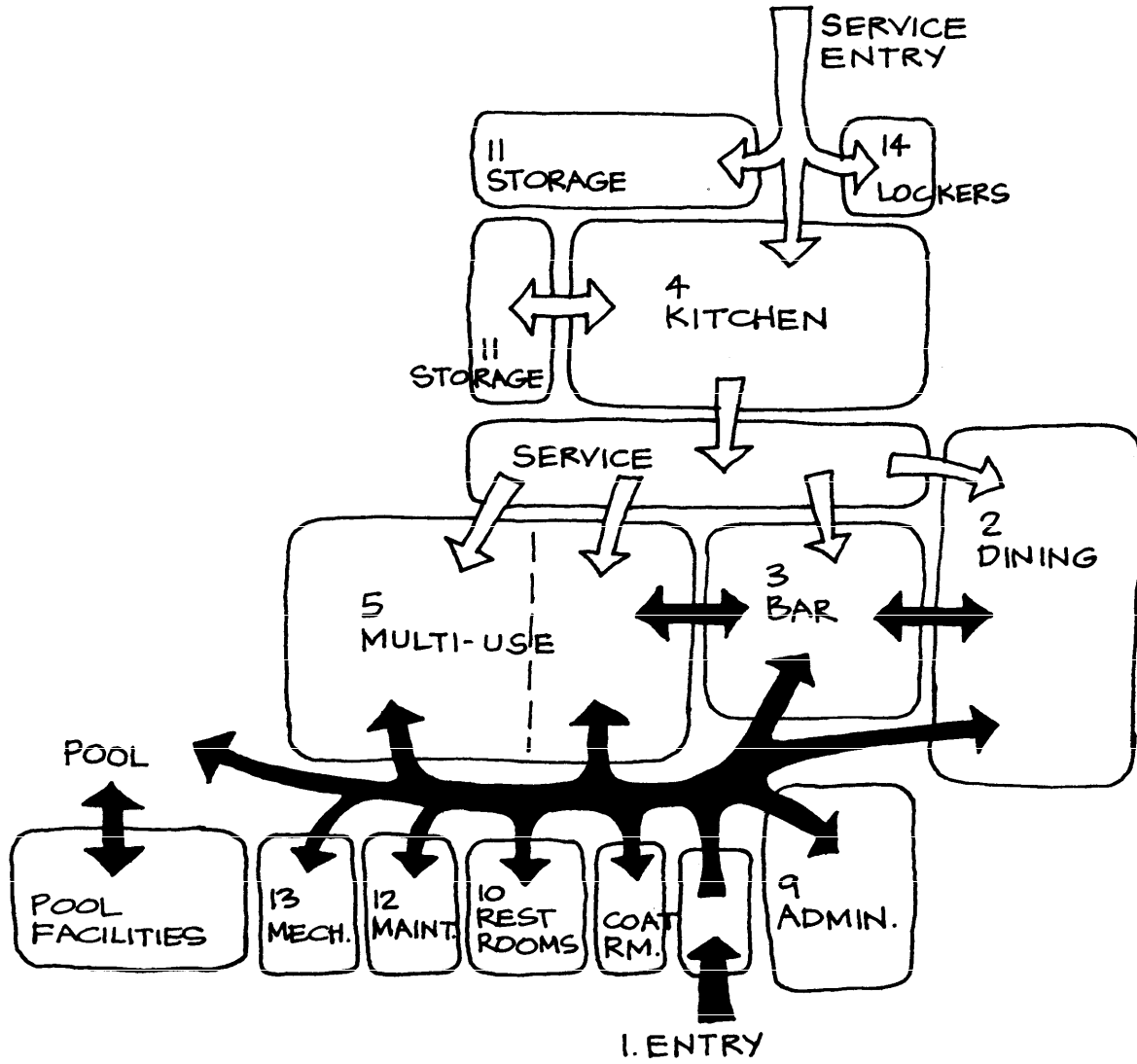

MEDIUM OFFICERS CLUB

7-4.6 STEP F - STRUCTURAL FRAMING

7-4.6.1 Structure: Bearing and shear wall, or two-way rigid frame. Bearing and shear wall design most economical, particularly in seismic areas, but not flexible for change or expansion.

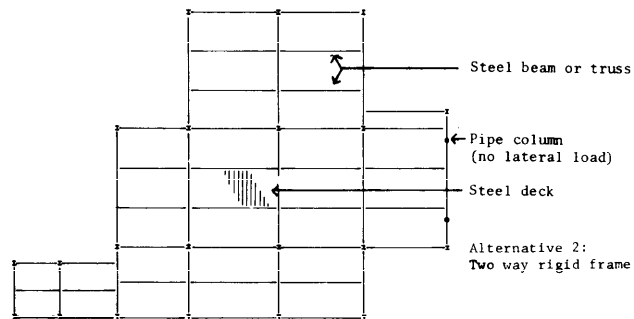
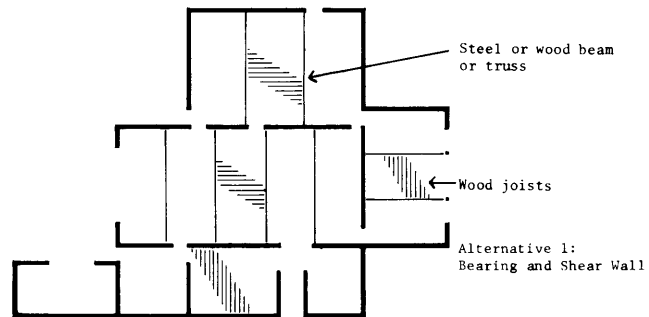

7-4.7 STEP G - SUBSYSTEM CHOICES

7-4.7.1 H.V.A.C.: System appropriate to climate.

7-4.7.2 Envelope: Masonry or concrete for load bearing and shear wall structure. Non-load bearing masonry or insulated panel infill for rigid frame structure.

7-4.7.3 Interior partitions: Non-load bearing replaceable partitions.

7-4.7.4 Ceiling: Systems appropriate to design requirements.

7-4.7.5 Lighting: Systems appropriate to design requirements.

7-4.8 STEP H - FLOOR PLAN

Figure 7-21 Floor Plan for Medium Officers Club

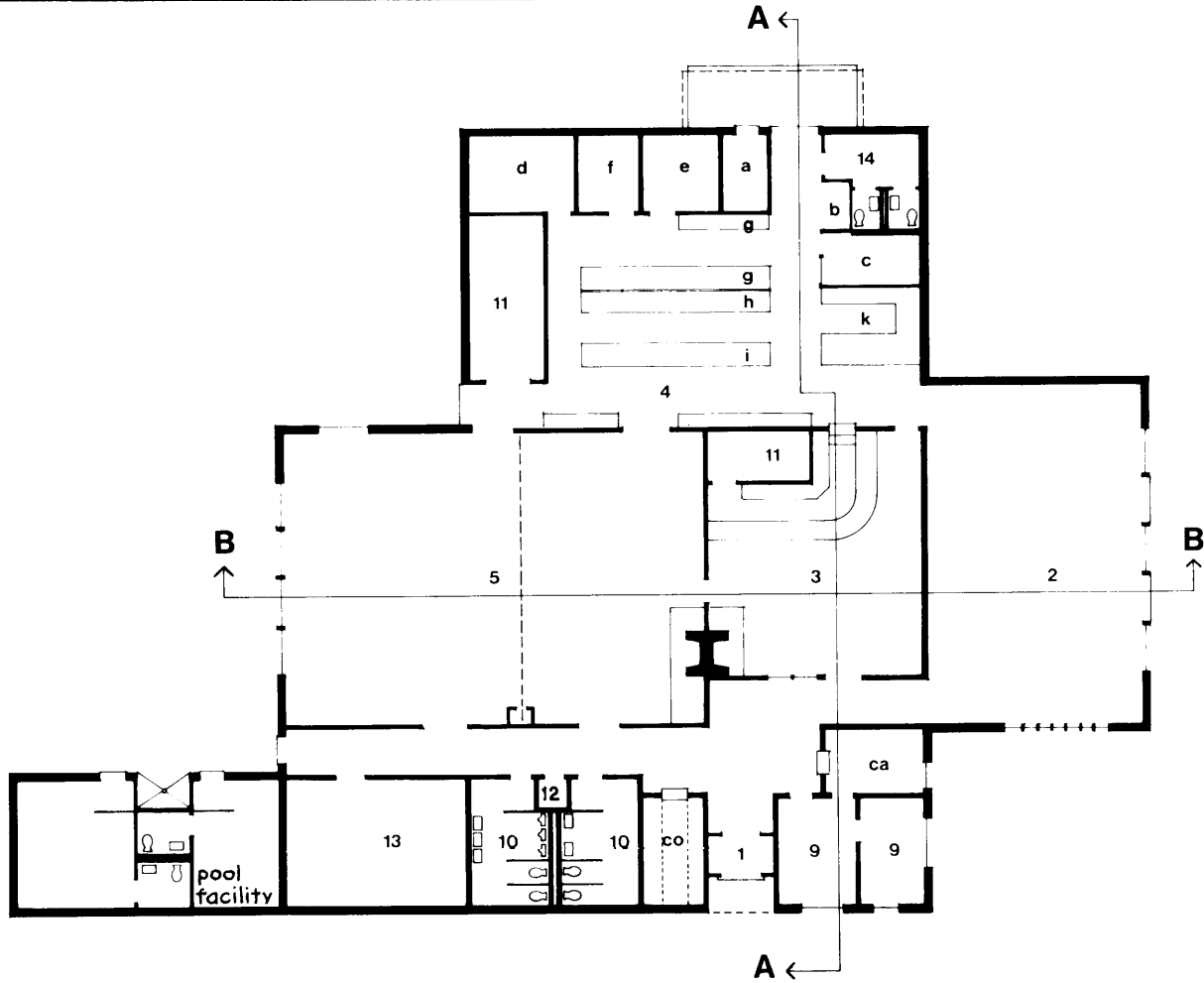

KEY

- | | |
|------------------------|----------------------|
| 1 entry | 5 ballroom/multi-use |
| co coatroom | 9 administration |
| 2 dining | ca cashier |
| 3 bar | 10 restrooms |
| 4 kitchen | 11 storage |
| a waste holding | 12 maintenance |
| b check-in | 13 mechanical |
| c chef's office | 14 locker room |
| d dry storage | |
| e refrigerated storage | |
| f freezer storage | |
| g preparation area | |
| h cooking area | |
| i serving area | |
| j banquet make-up | |
| k dishwashing | |

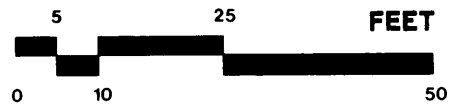

MEDIUM OFFICERS CLUB

7-4.9 STEP 1. - SECTIONS

Figure 7-22 Sections for Medium Officers Club

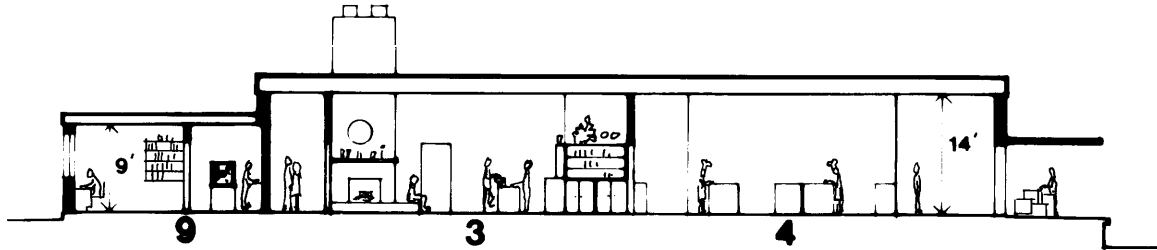

Section A - A

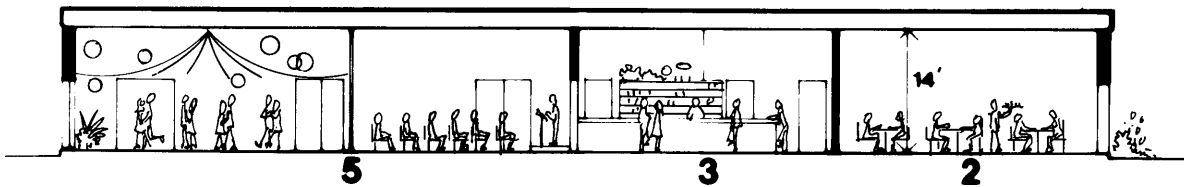

Section B - B

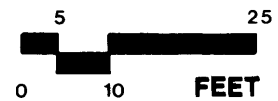

7-4.10 STEP J - SITE PLAN

Figure 7-23 Site Plan for Medium Officers Club

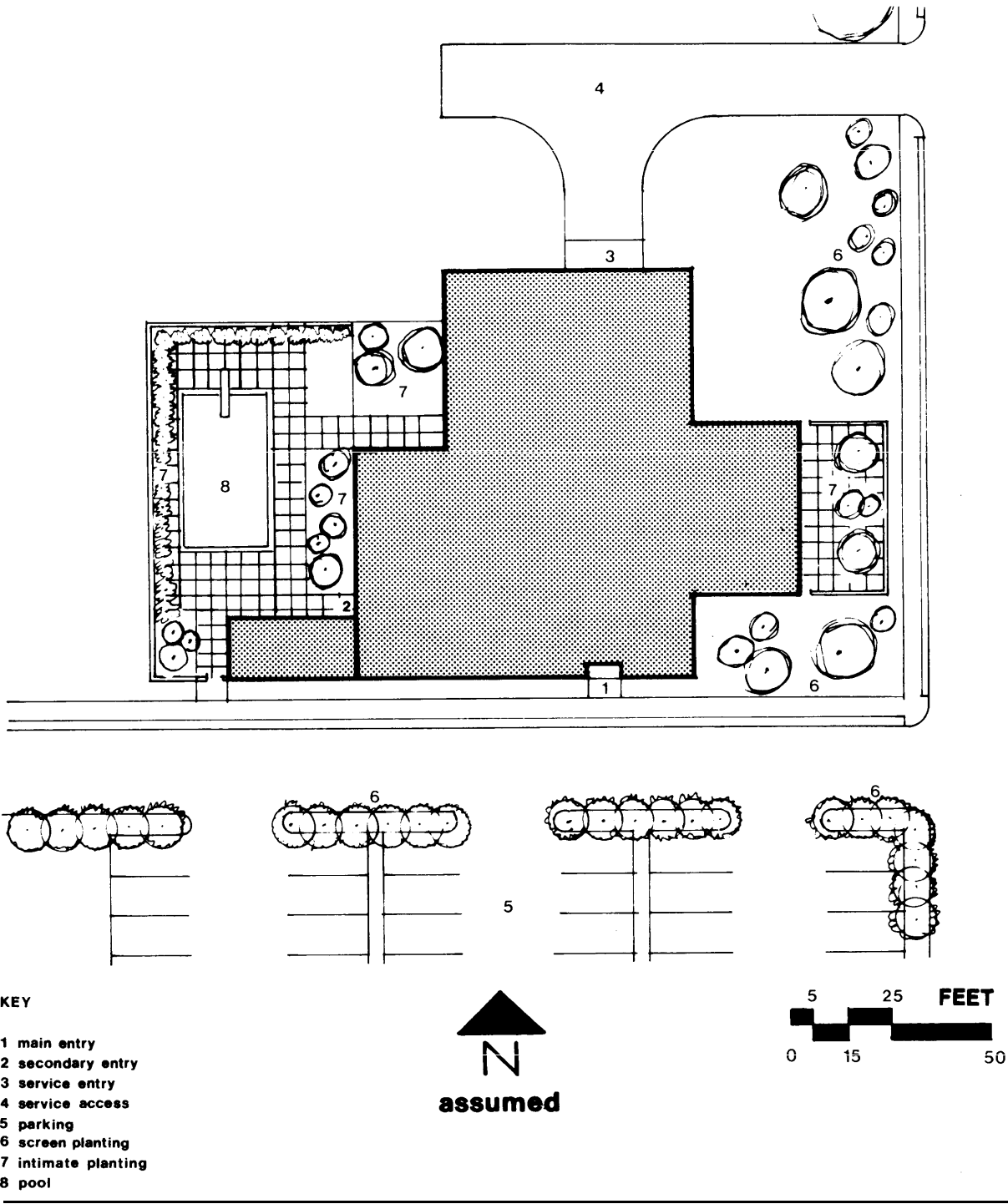

MEDIUM OFFICERS CLUB

7-4.11 STEP K - DESIGN ANALYSIS

7-4.11.1 Plan type: In-line plan.

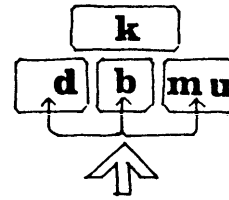

7-4.11.2 Design assumptions:
View from bar and multi-use room important.

7-4.11.3 Planning objectives:
Building.

- A. Orient dining room to private view.
- B. Provide terrace oriented to view with convenient food and bar service.
- C. Provide for easy expansion of dining room, multi-use room or both .

7-4.11.4 Planning evaluation:
Building.

- A. Dining, multi-use room and kitchen expansion provision good .
- B. Bar expansion possible only by remodeling dining and multi-use rooms, or building another bar.
- C. Mechanical room in front relates well to pool.
- D. Kitchen service to multi-use room, dining room, bar and outside patio excel lent.
- E. Kitchen service to pool good.
- F. Public circulation provides good access to all activity spaces.

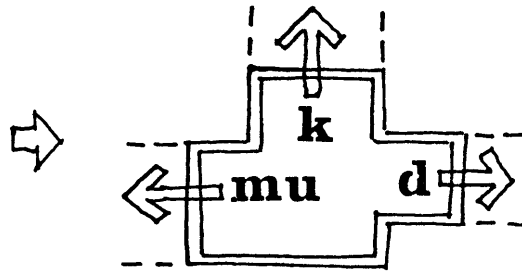

7-4.12 STEP L - PLANNING ALTERNATIVES

Figure 7-24 Alternative 1 for Medium Officers Club

Objectives: Provide side entry, provide multi-use storage.

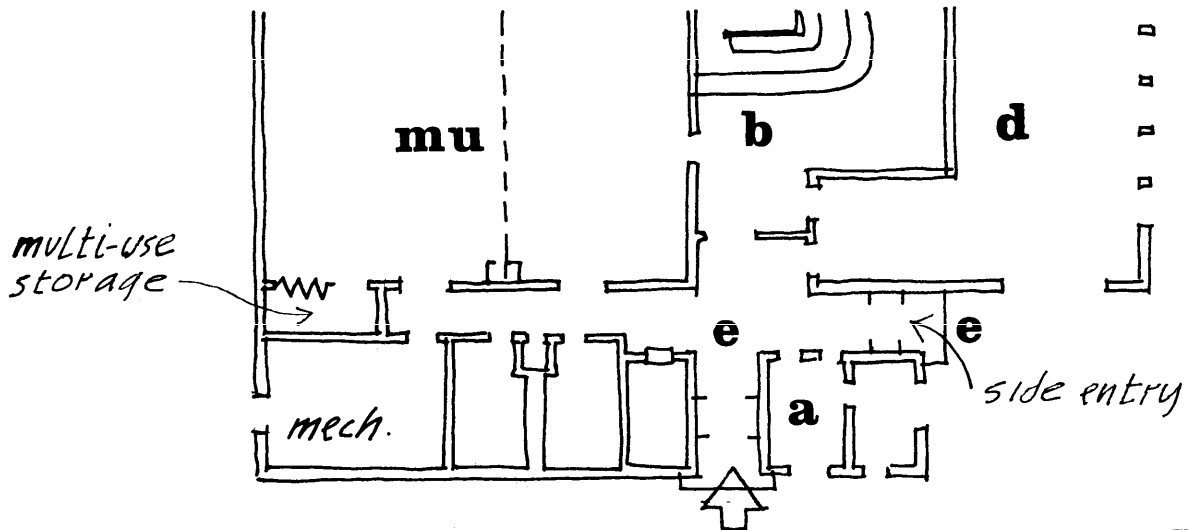
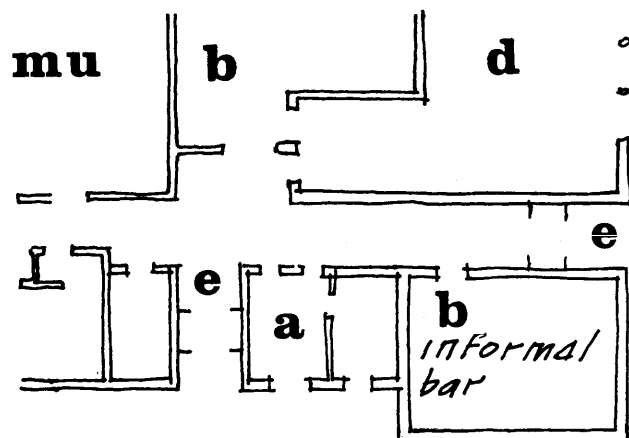

Figure 7-25 Alternative 2 for Medium Officers Club

Objective: Add informal bar with separate entry.



MEDIUM OFFICERS CLUB

7-4.13 STEP M - UTILITY & THERMAL LOADS

7-4.13.1 Building data

A. Gross floor area	7,806 s.f.
B. Max. population at one time	275
C. Max. meals served/day	400

7-4.13.2 Utility loads

A. Electrical : Light and power	205 kva
B. Water: Max. flow rate, cold water	60 gpm
Max. flow rate, hot water	60 gpm
Total flow per day	4,000 gal.
C. Sewage: Total gallons per day	4,000 gal.

7-4.13.3 Heating and cooling loads

A. Heating: Load	290 MBTU/hr.
B. Air conditioning: Tons of refrigeration	35 tons

7-4.13.4 Design assumptions.

All policy and design criteria per DOD 4270.1-M.

- A. Estimates are for plans shown
- B. 40° North latitude.
- C. Heat load in kitchen not included in heat gain calculations.
- D. Mechanical room ventilated only.
- E. Single glazing, standard glass.
- F. 20% outside air assumed for ventilation.
- G. Assumed perimeter heat loss: 40 BTU/hr./ft.
- H. Sewage demand based on 10 gpd per person, max. occupancy.
- I. Lighting load assumed 2.5 watts/s.f.

7-5.1 STEP A - SPACE PROGRAM: The space program shown in Figure 7-26 is based on a need to seat 225-240 for dining, plus simultaneous banquet facilities in the multi-use and party room. The design example shows a one-story solution.

Figure 7-26 Space Program for Large Officers Club A

Generic Space	Program Area	% Gross Area
1 - Entry	1,740	6.8
2 - Dining Room	3,364	13.2
3 - Bar	2,376	9.3
4 - Kitchen	5,016	19.8
5 - Multi-use	4,072	16
6 - Party Rooms	1,170	4.6
7 - Rec. Room (Q)	986	3.9
8 - Rec. Room (N)	280	1.1
9 - Administration	1,100	4.3
10 - Rest Rooms	760	2.9
11 - Storage	652	2.5
12 - Maintenance	28	.1
13 - Mechanical	988	3.9
14 - Lockers	412	1.6
Net Usable	22,944	90
Gross Area	25,494	100
Dining Room Occupancy:	224 @ 15 sq. ft./seat	
Ballroom Occupancy:	250 - bingo	
	288 - banquet	
Net usable: gross area ratio:	0.90	

For basis upon which the space program is developed, see Sections 2 and 3.

LARGE OFFICERS CLUB

7-5.2 STEP B - AFFINITY MATRIX: The affinity matrix shown in Figure 7-27 indicates relationships between the generic spaces as being desirable (+), of no consequence (0), or undesirable (-). This is based upon use patterns, acoustic compatibility, mutual support for functional operation, sanitary or other reasons. The matrix is intended to denote the desirability of adjacency or separation per se, and along with the space program, is part of the problem statement generated by the using service.

Figure 7-27 Affinity Matrix for Large Officers Club A

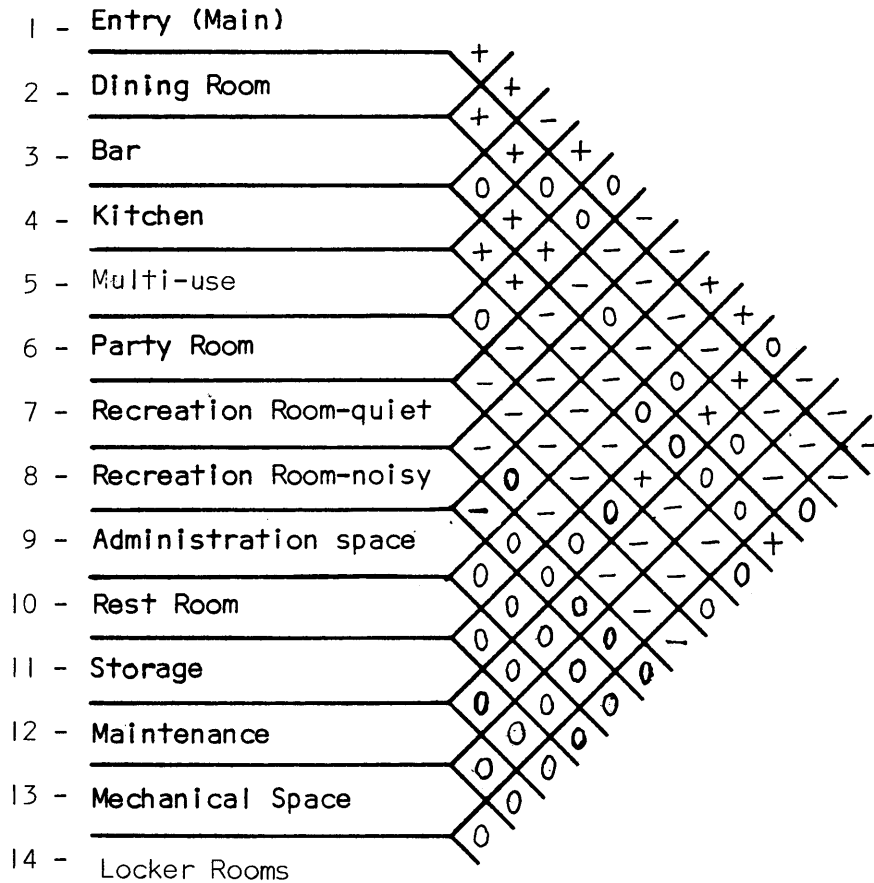

7-5.3 STEP C - AFFINITY DIAGRAM (NO SCALE)

Figure 7-28 Affinity Diagram for Large Officers Club A (no scale)

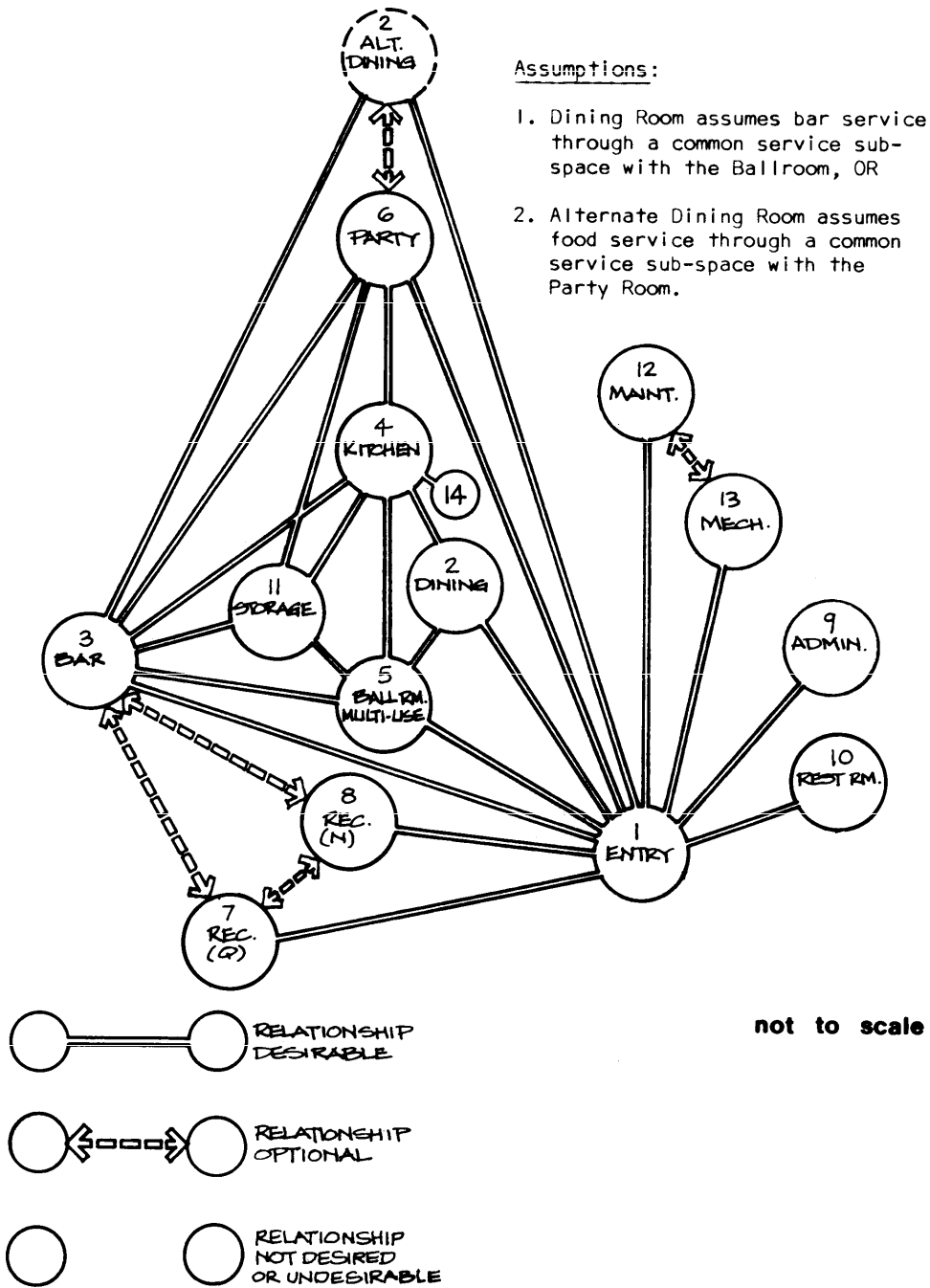

LARGE OFFICERS CLUB

7-5.4 STEP D - AFFINITY DIAGRAM (TO SCALE)

Figure 7-29 Affinity Diagram for Large Officers Club A (to scale)

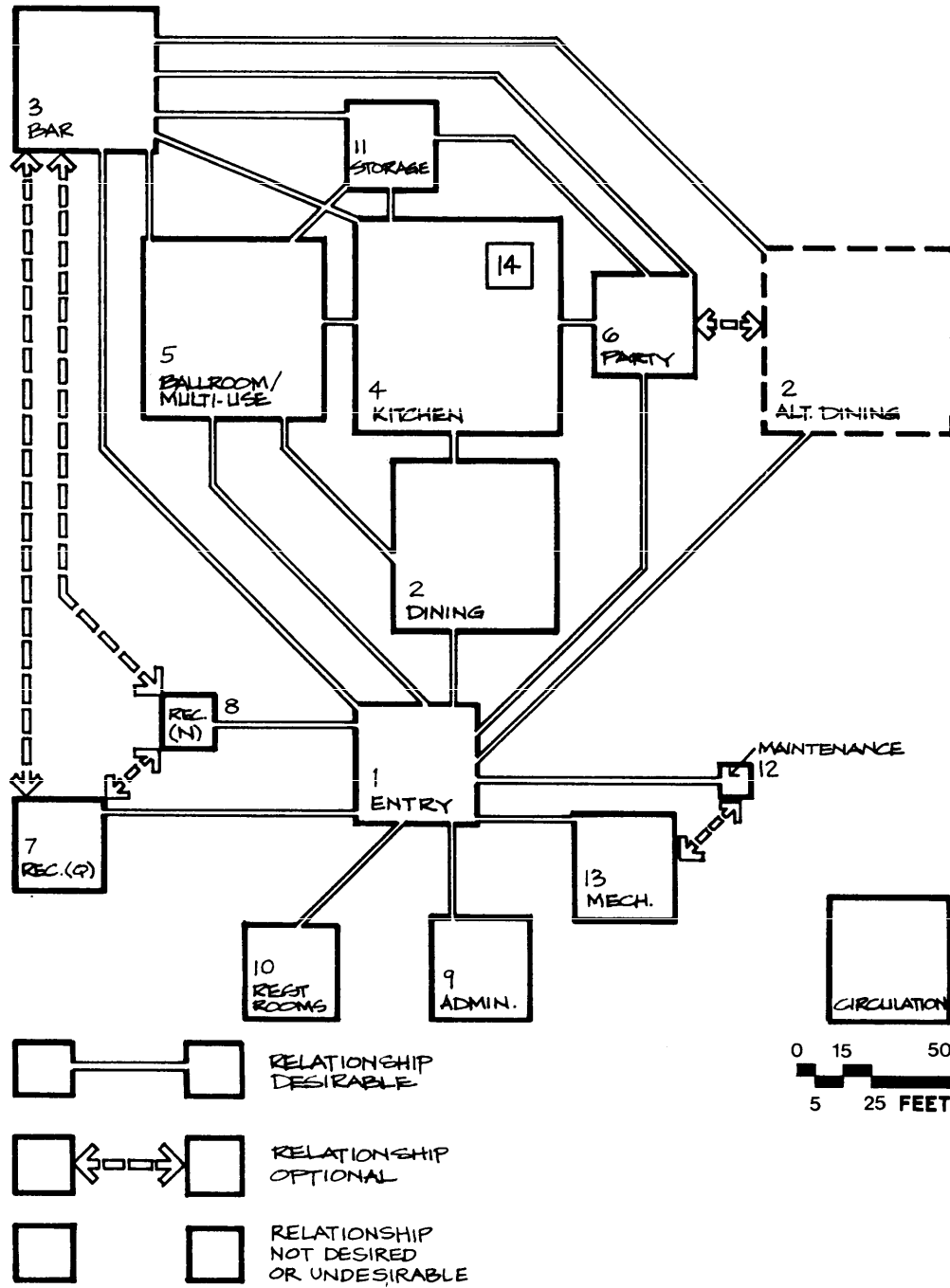

7-5.5 STEP E - PLANNING DIAGRAM

Figure 7-30 Planning Diagram for Large Officers Club A

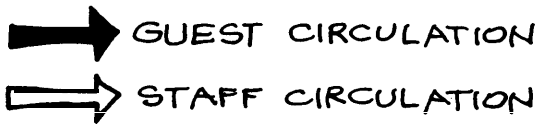
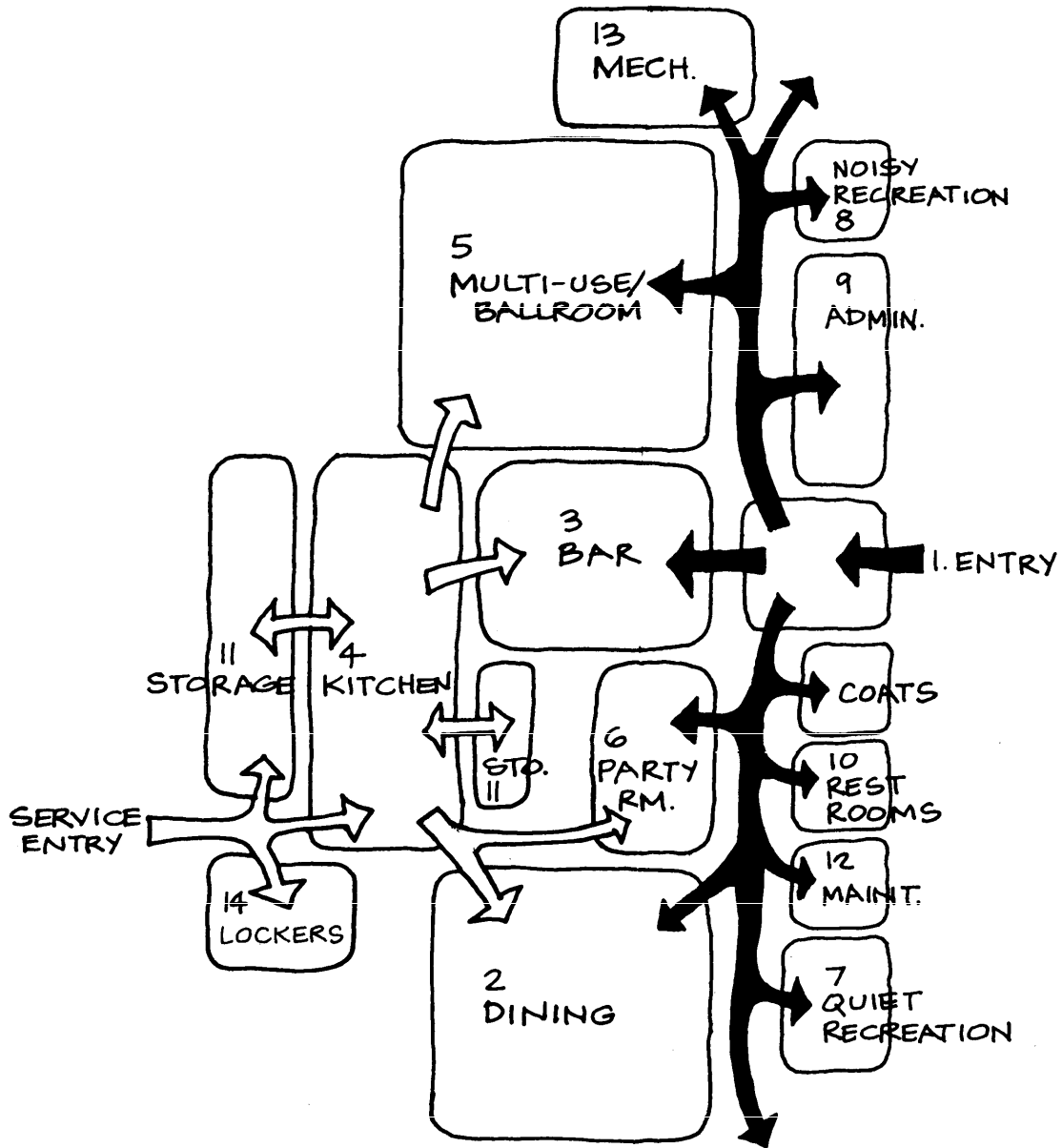

LARGE OFFICERS CLUB

7-3.6 STEP F - STRUCTURAL FRAMING

7-3.6.1 Structure: Alternative 1 uses bearing and shear walls in combination with steel beams and girders. Interior shear walls are necessary, and wide span framing is used to maintain adequate flexibility. Alternative 2 uses a two-way rigid frame for maximum flexibility.

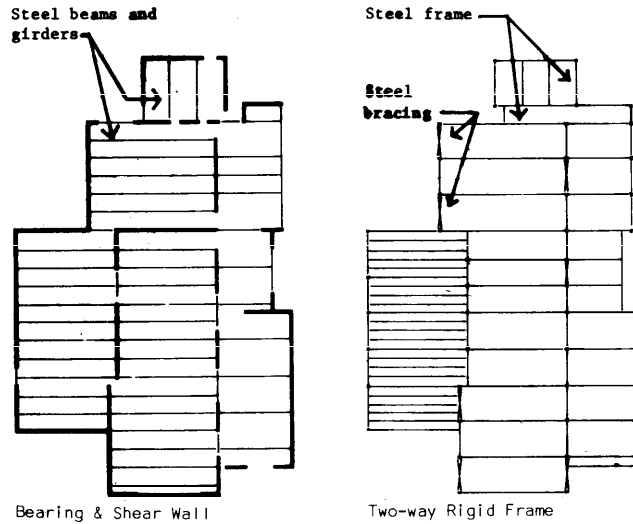

7-5.7 STEP G - SUBSYSTEM CHOICES

7-5.7.1 H.V.A.C.: System appropriate to climate.

7-5.7.2 Envelope: Masonry or concrete for load bearing and shear wall structure. Non-load bearing masonry or insulated panel infill for rigid frame structure.

7-5.7.3 Interior partitions: Non-load bearing replaceable.

7-4.7.4 Ceiling: Systems appropriate to design requirements.

7-4.7.5 Lighting: Systems appropriate to design requirements.

7-5.8 STEP H - FLOOR PLAN

Figure 7-31 Floor Plan for Large Officers Club A

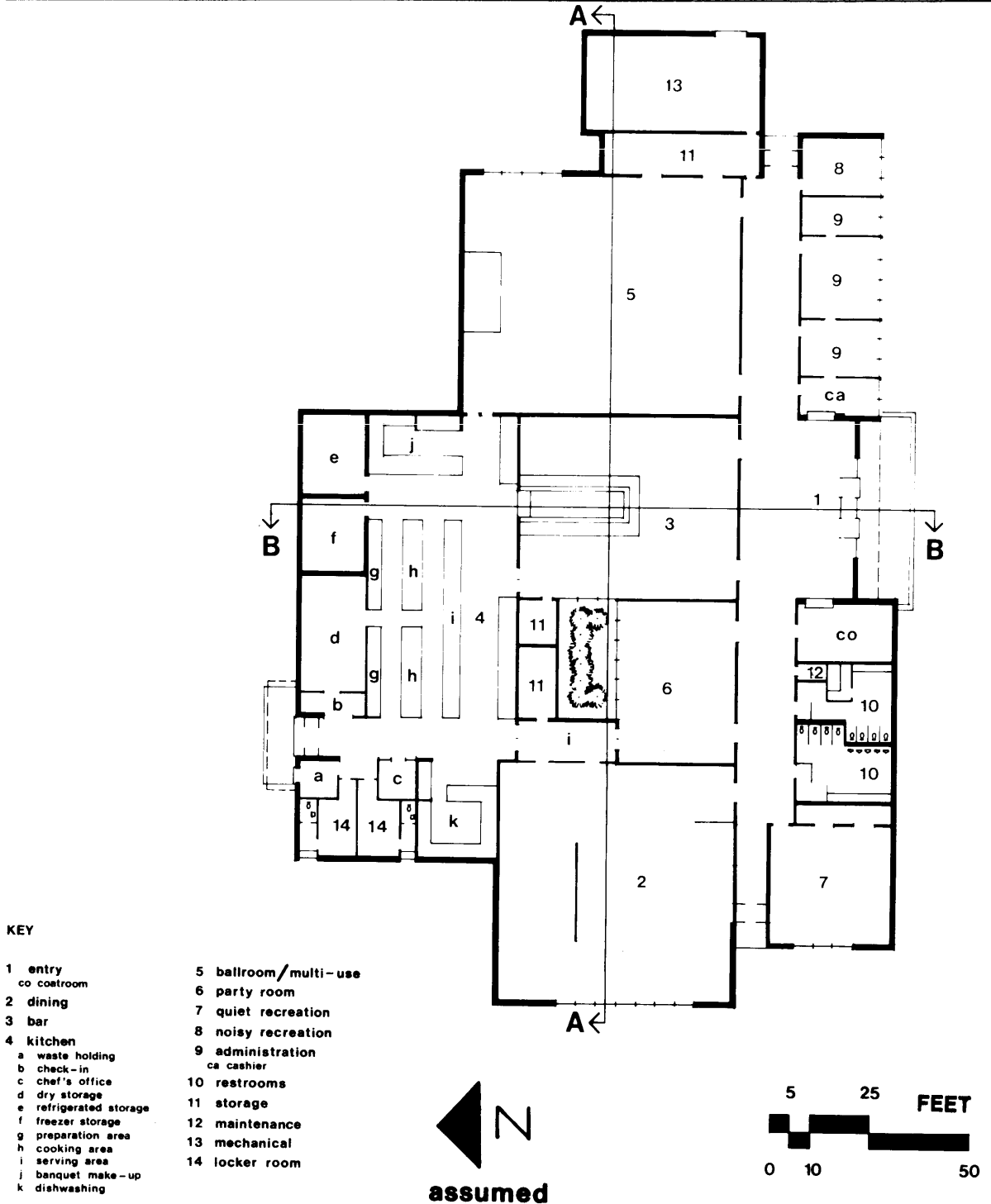

LARGE OFFICERS CLUB

7-5.9 STEP 1 - SECTIONS

Figure 7-32 Sections for Large Officers Club A

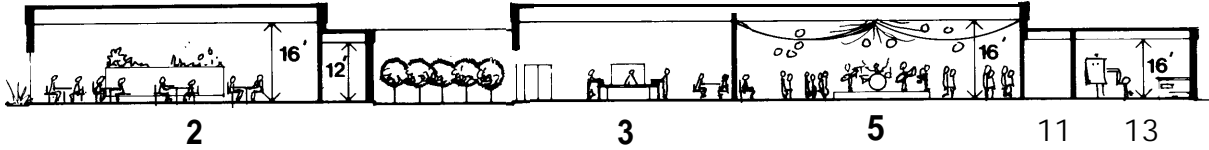

Section A - A

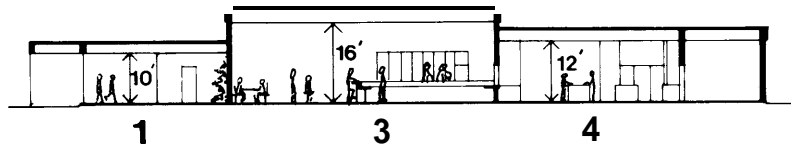

Section B - B



7-5.10 STEP J - SITE PLAN

Figure 7-33 Site Plan for Large Officers Club A

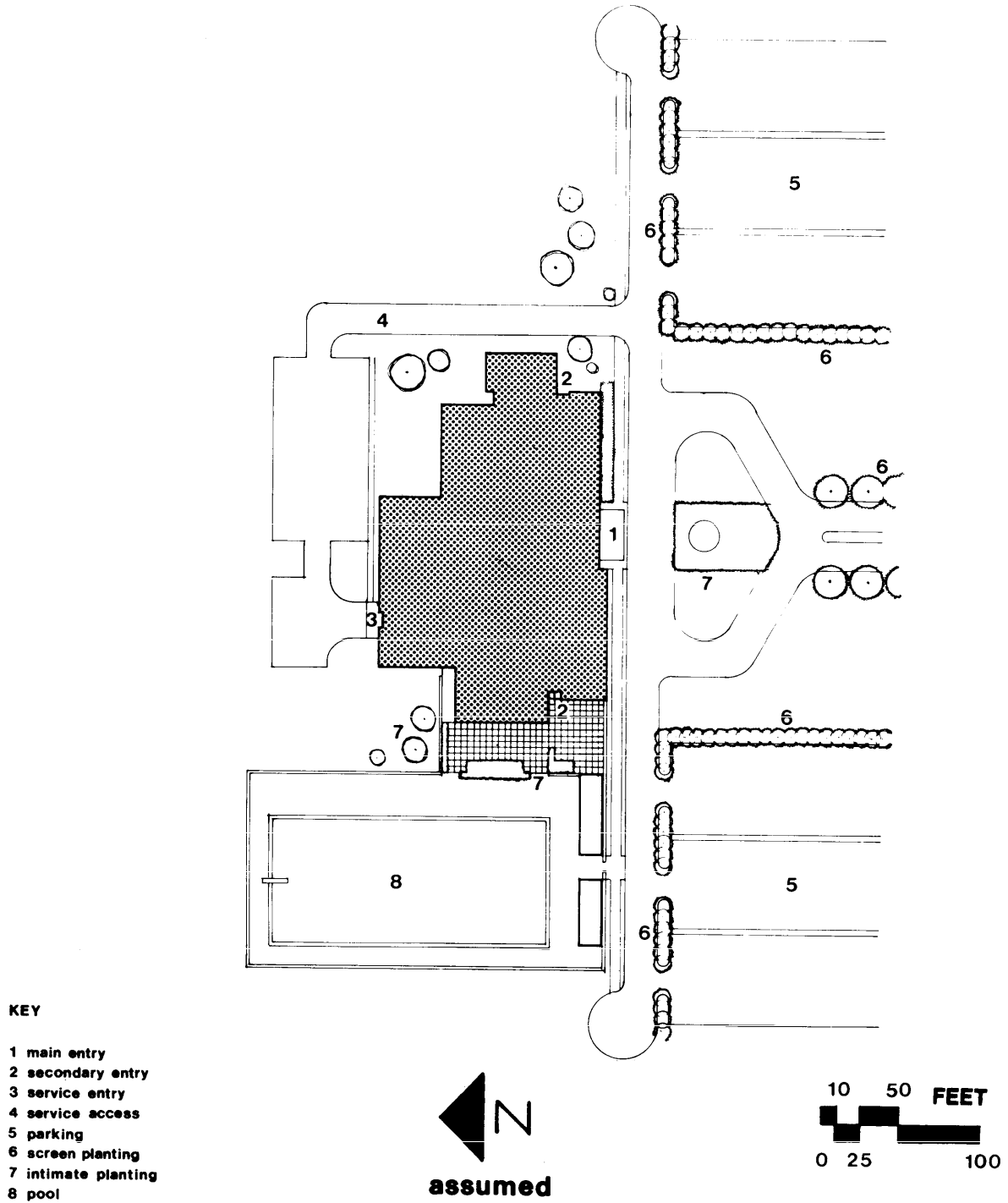

LARGE OFFICERS CLUB

7-5.11 STEP K - DESIGN ANALYSIS

7-5.11.1 Plan type: In-line plan.

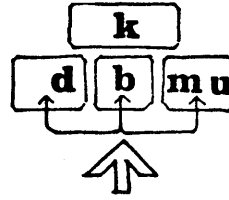

7-5.11.2 Design assumptions

- A. Attractive view to west.
- B. View from bar and multi-use room unimportant.

7-5.11.3 Planning objectives: Building.

- A. Orient dining room to view.
- B. Provide terrace oriented to view with convenient bar and food service.
- C. Provide separate entry convenient to multi-use room.
- D. Provide one bar, with possibility of subdivision into formal and informal.
- E. Provision for multi-use expansion unimportant.
- F. Provision for dining room and kitchen expansion important.
- G. Flexibility between dining room/multi-use room unimportant.

7-5.11.4 Planning evaluation: Building.

- A. Expansion provision for dining room and kitchen good.
- B. Excellent simple circulation to all major spaces.
- C. Good location for quiet recreation room (dead end location).
- D. Good location for noisy recreation room, except no direct bar service.
- E. Separate entry to multi-use adjoins noisy recreation room, which is not desirable.

7-5.12 STEP L - PLANNING ALTERNATIVES

Figure 7-34 Planning Alternatives for Large Officers Club A

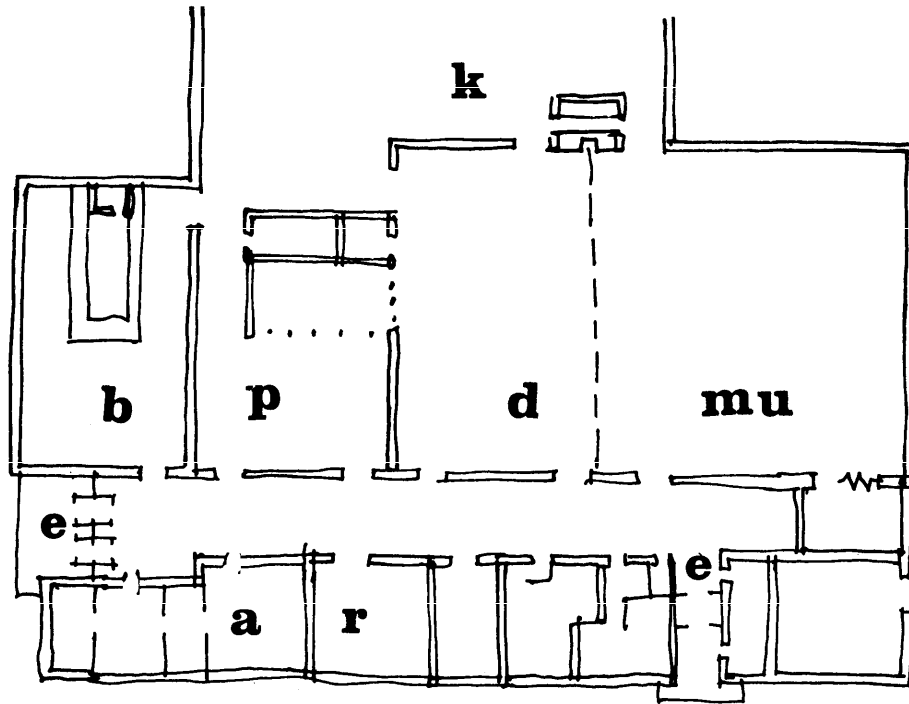

Objective: illustrate alternative in-line plan, and provide flexibility between dining and multi-use room.

entrance location revised in order to remain close to bar.

LARGE OFFICERS CLUB

7-5.13 STEP M - UTILITY & THERMAL LOADS

7-5.13.1 Building data

- | | |
|--------------------------------|-------------|
| A. Gross floor area | 25,494 s.f. |
| B. Max. population at one time | 875 |
| C. Max. meals served/day | 1,075 |

7-5.13.2 Utility loads

- | | |
|--------------------------------------|-------------|
| A. Electrical: Light and power | 760 kva |
| B. Water: Max. flow rate, cold water | 57 gpm |
| Max. flow rate, hot water | 57 gpm |
| Total flow per day | 10,750 gal. |
| C. Sewage: Total gallons per day | 10,750 gal. |

7-5.13.3 Heating and cooling loads

- | | |
|--|--------------|
| A. Heating: Load | 692 MBTU/hr. |
| B. Air conditioning: Tons of refrigeration | 99 tons |

7-5.13.4 Design assumptions

All policy and design criteria per DOD 4270.1-M.

- A. Estimates are for plans shown.
- B. 40° North latitude.
- D. Heat load in kitchen not included in heat gain calculations.
- E. Single glazing, standard glass.
- F. 20% outside air assumed for ventilation.
- G. Assumed perimeter heat loss: 40 BTU/hr./ft.
- H. Sewage demand based on 10 gpd per person, max. occupancy.
- I. Lighting load assumed 2.5 watts/s.f.

7-6.1 STEP A - SPACE PROGRAM: The space program shown in Figure 7-35 is based on a need to seat 100 for dining, plus simultaneous banquet and party room facilities in a flexible multi-use room. Military strength served is 401-750 NCOs.

Figure 7-35 Space Program for Small NCO Club

Generic Space	Program Area	% Gross Area
1 - Entry	559.5	6.1
2 - Dining Room	1,407	15.3
3 - Bar	1,243.5	13.5
4 - Kitchen	1,488.5	16.2
5 - Multi-use	2,140	23.2
6 - Party Rooms	---	---
7 - Rec. Room (Q)	---	---
8 - Rec. Room (N)	---	---
9 - Administration	430	4.7
10 - Rest Rooms	288.5	3.1
11 - Storage	271.5	2.9
12 - Maintenance	20	.2
13 - Mechanical	336	3.6
14 - Lockers	116	1.2
Net Usable	8,295.5	90
Gross Area	9,217	100
Dining Room Occupancy:	100 @ 14 sq. ft./seat	
Ballroom Occupancy:	143 - bingo	
	165 - banquet	
Net usable: gross area ratio:	0.90	

For basis upon which the space program is developed, see Sections 2 and 3.

SMALL NCO CLUB

7-6.2 STEP B - AFFINITY MATRIX: The affinity matrix shown in Figure 7-36 indicates relationships between the generic spaces as-being desirable (+), of no consequence (0), or undesirable (-). This is based upon use patterns, acoustic compatibility, mutual support for functional operation, sanitary or other reasons. The matrix is intended to denote the desirability of adjacency or separation per se, and along with the space program, is part of the problem statement generated by the using service.

Figure 7-36 Affinity Matrix for Small NCO Club

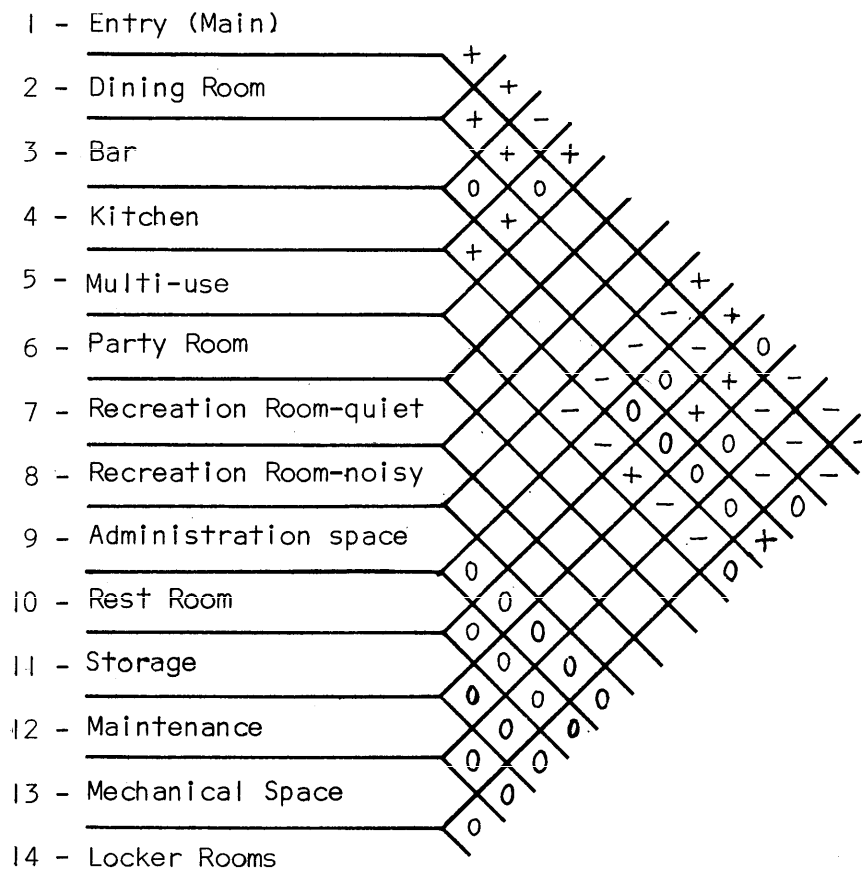

7-6.3 STEP C - AFFINITY DIAGRAM (NO SCALE)

Figure 7-37 Affinity Diagram for Small NCO Club (no scale)

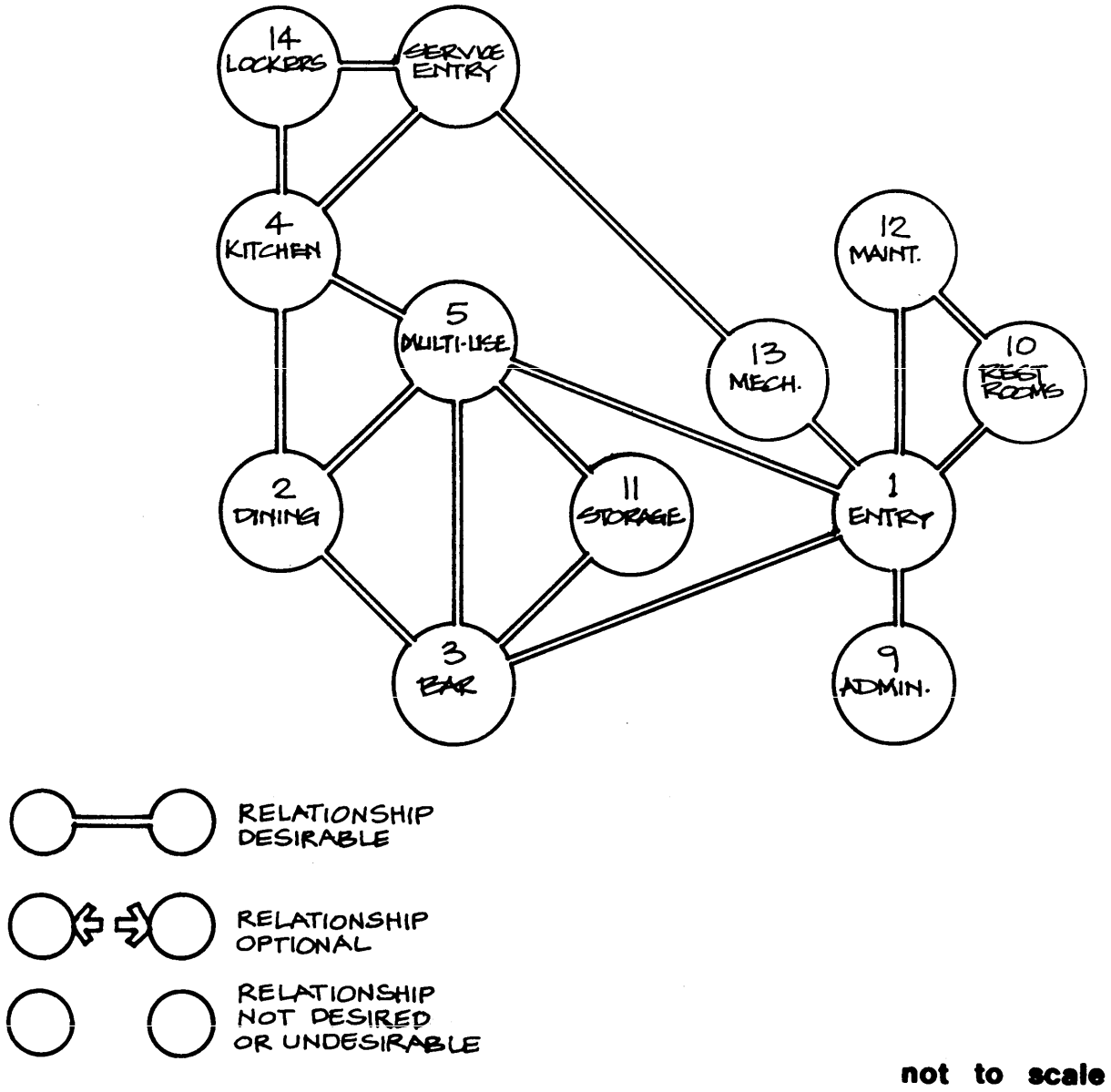

7-6.5 STEP E - PLANNING DIAGRAM

Figure 7-39 Planning Diagram for Small NCO Club

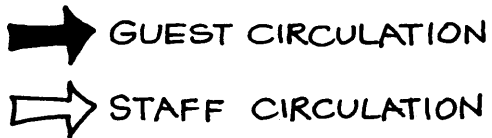
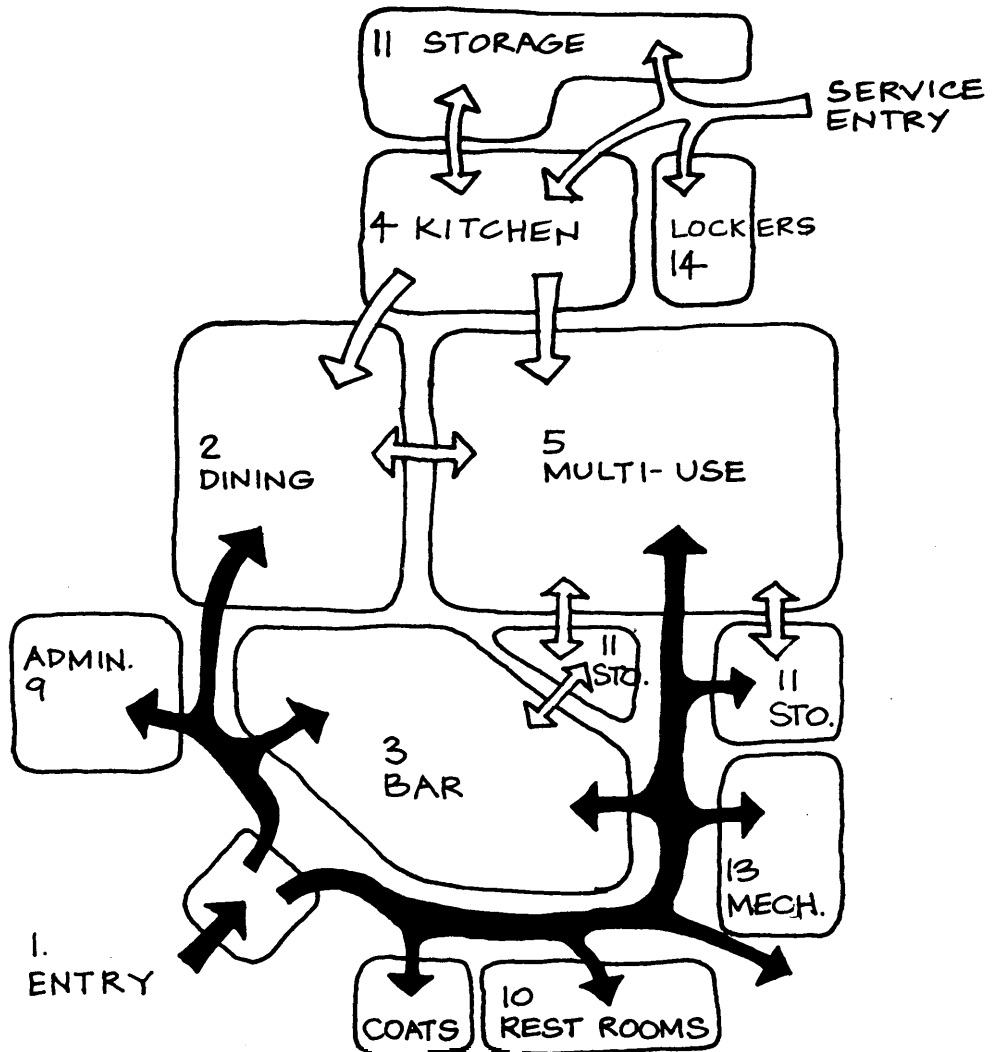

SMALL NCO CLUB

7-6.6 STEP F - STRUCTURAL FRAMING

7-6.6.1 Structure: Bearing and shear wall framing: Flexibility is not impeded, since walls can be confined to exterior of building.

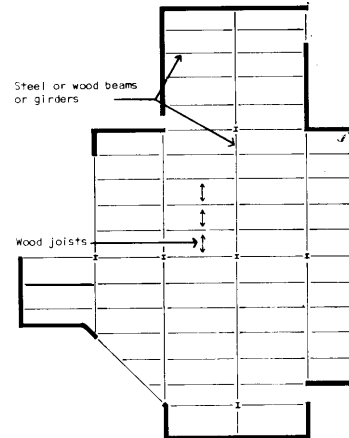

7-6.7 STEP G - SUBSYSTEM CHOICES

7-6.7.1 H.V.A.C.: System appropriate to climate.

7-6.7.2 Envelope: Masonry or concrete.

7-6.7.3 Interior partitions: Non-load bearing replaceable partitions, operable walls in multi-use room.

7-6.7.4 Ceiling: Systems appropriate to design requirements.

7-6.7.5 Lighting: Systems appropriate to design requirements.

7-6.8 STEP H - FLOOR PLAN

Figure 7-40 Floor Plan for Small NCO Club

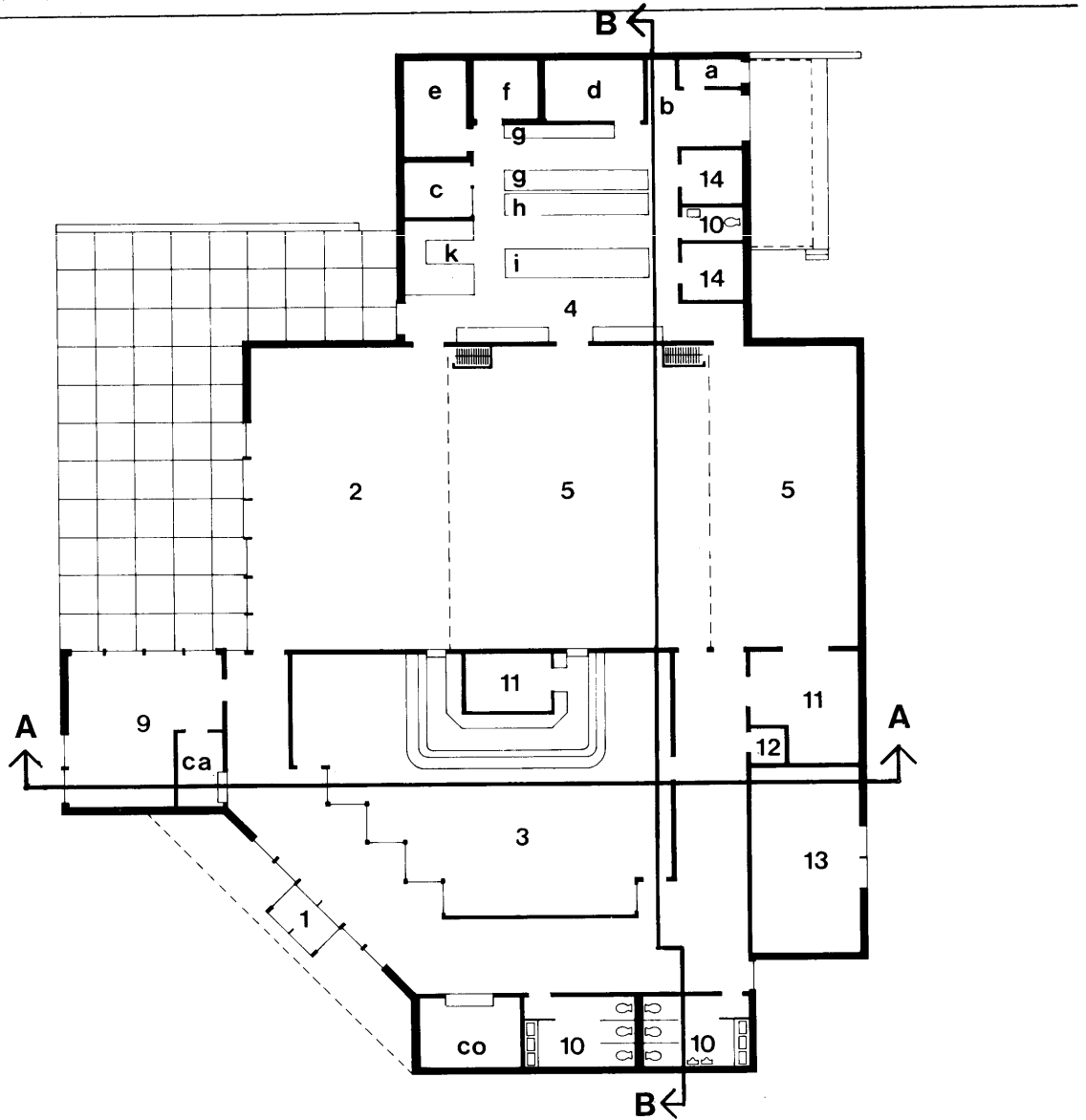

KEY

- | | |
|------------------------|----------------------|
| 1 entry | 5 ballroom/multi-use |
| co costroom | 9 administration |
| 2 dining | ca cashier |
| 3 bar | 10 restrooms |
| 4 kitchen | 11 storage |
| a waste holding | 12 maintenance |
| b check-in | 13 mechanical |
| c chef's office | 14 locker room |
| d dry storage | |
| e refrigerated storage | |
| f freezer storage | |
| g preparation area | |
| h cooking area | |
| i serving area | |
| k dishwashing | |

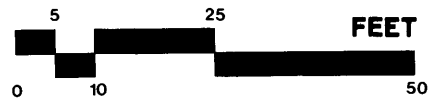

SMALL NCO CLUB

7-6.9 STEP I - SECTIONS

Figure 7-4 I Sections for Small NCO Club

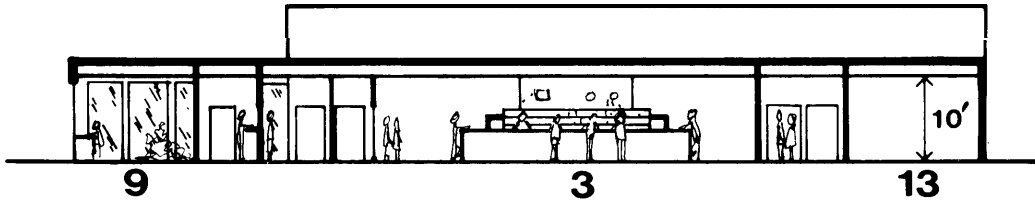

section A-A

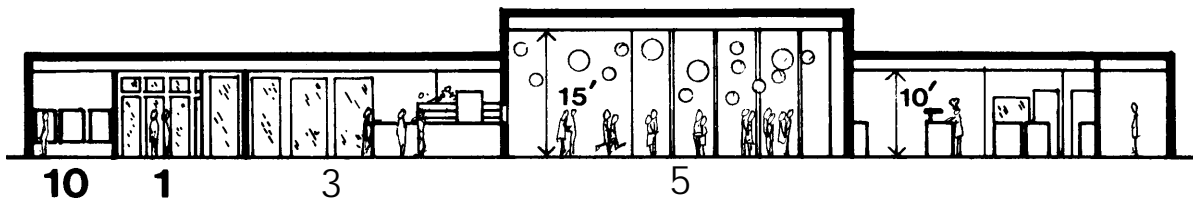

section B-B

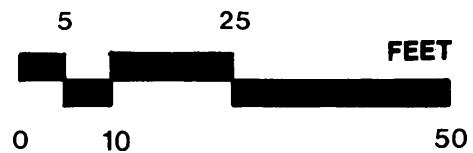

7-6.10 STEP J - SITE PLAN

Figure 7-42 Site Plan for Small NCO Club

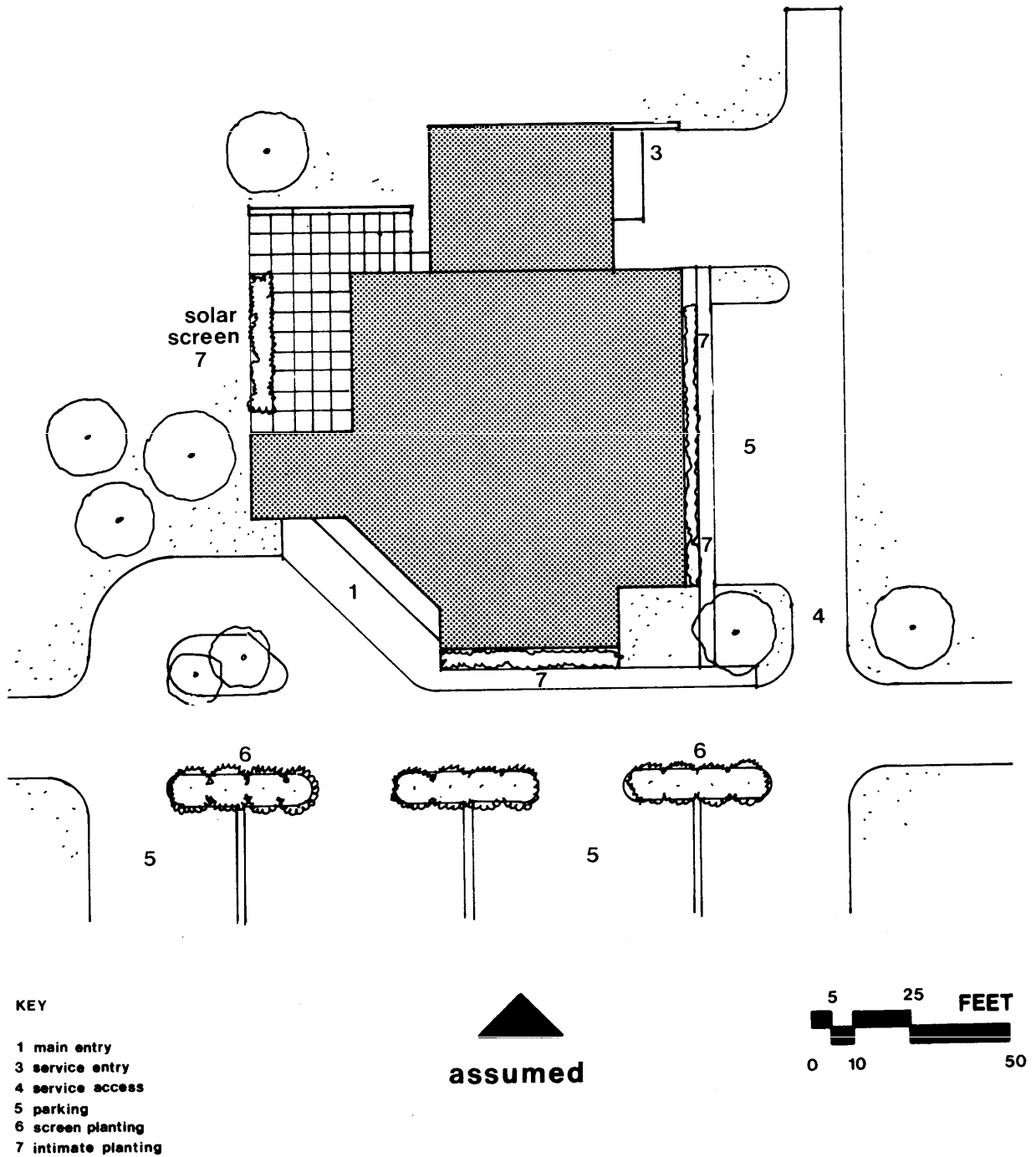

SMALL NCO CLUB

7-6.11 STEP K - DESIGN ANALYSIS

7-6.11.1 Plan type: Three-way plan.

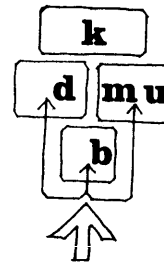

7-6.11.2 Design assumptions:
Attractive view to west.

7-6.11.3 Planning objectives:
Building.

- A. Flexibility important between dining room and multi-use; small club with highly varying party and banquet service.
- B. Exploit corner entry in interesting way.
- C. Subdivide main circulation and place most-used spaces closest to entry.
- D. Provide for expansion.

7-6.11.4 Planning evaluation:
Building,

- A. Good flexibility between multi-use room and dining room. Six different size spaces available.

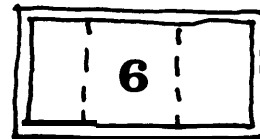
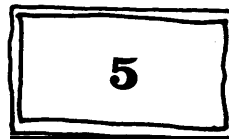
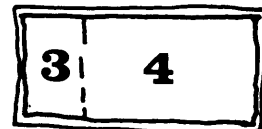
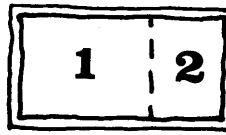

- B. Attractive corner entry well related to circulation areas.

-
- C. Good kitchen and bar service to dining room and multi-use rooms.
 - D. Easy to arrange separate entry, though probably not useful at present size.
 - E. Subdivided circulation with good variety in character of spaces.

7-6.11.5 Planning objectives: Site.

- A. Relate site planning to corner entry.
- B. Provide screened terrace off dining area with food servicing possible.

7-6.11.6 Planning evaluation: Site.

- A. Good solution of corner entrance.
- B. West facing dining room protected from late afternoon solar glare by screened planting.

SMALL NCO CLUB

7-6.12 STEP L - PLANNING ALTERNATIVES

Figure 7-43 Alternative I for Small NCO Club

Objective: Provide side entry to club.

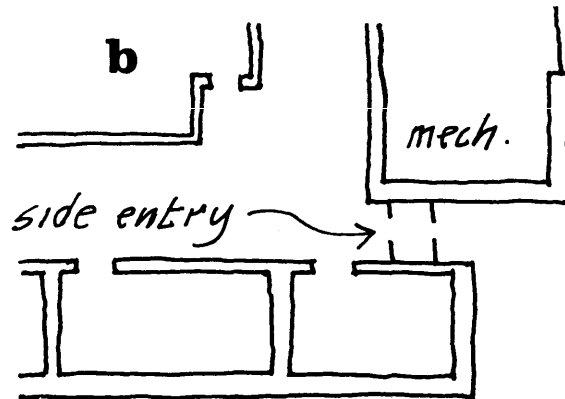
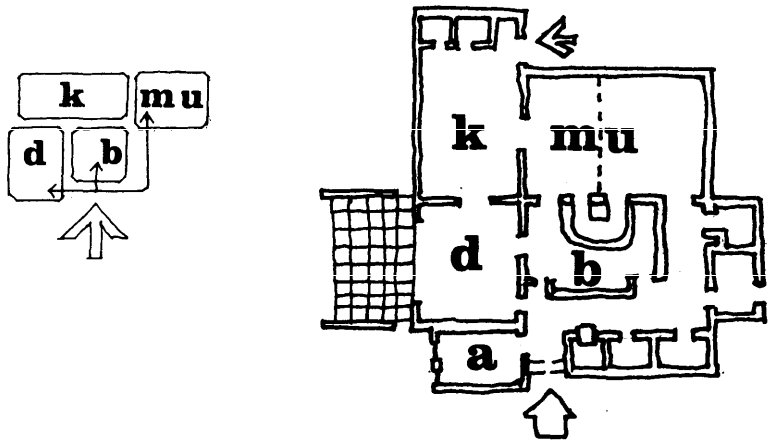

Figure 7-44 Alternative 2 for Small NCO Club

Objective: Illustrate 2-way plan variation. More compact circulation, but no flexibility between dining and multi-use rooms.



SMALL NCO CLUB

7-6.13 STEP M - UTILITY & THERMAL LOADS

7-6.13.1 Building data

A. Gross floor area	9,217 s.f.
B. Max. population at one time	305
C. Max. meals served/day	400

7-6.13.2 Utility loads

A. Electrical: Light and power	250 kva
B. Water: Max. flow rate, cold water	60 gpm
Max. flow rate, hot water	60 gpm
Total flow per day	4,000 gal.
C. Sewage: Total gallons per day	4,000 gal.

7-6.13.3 Heating and cooling loads

A. Heating: Load	302 MBTU/hr.
B. Air conditioning: Tons of refrigeration	40 tons

7-6.13.4 Design assumptions

All policy and design criteria per DOD 4270.1-M.

- A. Estimates are for plans shown.
- B. 40° North latitude.
- C. Heat load in kitchen not included in heat gain calculations.
- D. Mechanical room ventilated only.
- E. Single glazing, standard glass.
- F. 20% outside air assumed for ventilation.
- G. Assumed perimeter heat loss: 40 BTU/hr./ft.
- H. Sewage demand based on 10 gpd per person, max. occupancy.
- I. Lighting load assumed 2.5 watts/s.f.

7-7 MEDIUM NCO CLUB

7-7.1 STEP A - SPACE PROGRAM: The space program shown in Figure provides for separate bars; one associated with the main entrance and dining room, the other functioning as an informal bar related to a separate entrance. In addition, a separate party room is required. Military strength served is 1251-2000 NCOS.

Figure 7-45 Space Program for Medium NCO Club

Generic Space	Program Area	% Gross Area
1 - Entry	1,362.5	7.7
2 - Dining Room	2,963	16.8
3 - Bar	1,345.5	7.6
4 - Kitchen	2,740	15.6
5 - Multi-use	2,942.5	16.7
6 - Party Rooms	750	4.3
7 - Rec. Room (Q)	575.5	3.3
8 - Rec. Room (N)	294	1.7
9 - Administration	894	5.1
10 - Rest Rooms	361.5	2.1
11 - Storage	666.5	3.8
12 - Maintenance	43	.2
13 - Mechanical	696	3.9
14 - Lockers	214	1.2
Net Usable	15,848	90
Gross Area	17,609	100
Dining Room Occupancy:	211 @ 14 sq. ft./seat	
Ballroom Occupancy:	187 - bingo	
	216 - banquet	
Net usable: gross area ratio:	0.90	

For basis upon which the space program is developed, see Sections 2 and 3.

MEDIUM NCO CLUB

7-7.2 STEP B - AFFINITY MATRIX: The affinity matrix shown in Figure indicates relationships between the generic spaces as being desirable (+), of no consequence (0), or undesirable (-). This is based upon use patterns, acoustic compatibility, mutual support for functional operation, sanitary or other reasons. The matrix is intended to denote the desirability of adjacency or separation per se, and along with the space program, is part of the problem statement generated by the using service.

Figure 7-46 Affinity Matrix for Medium NCO Club

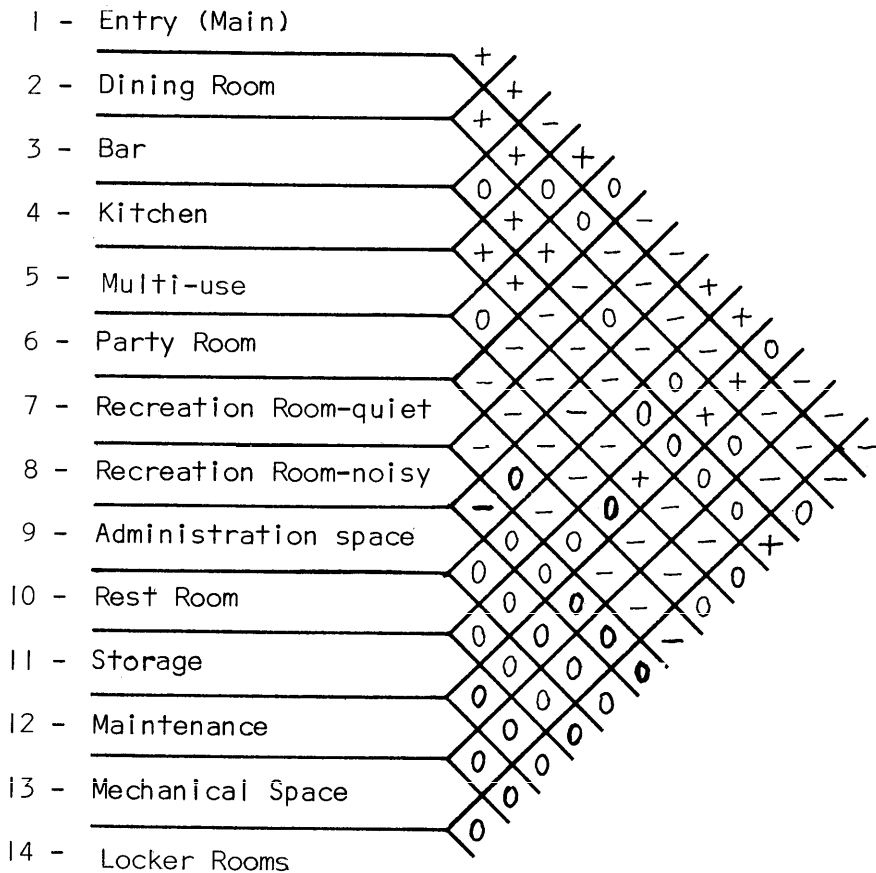

7-7.3 STEP C - AFFINITY DIAGRAM (NO SCALE)

Figure 7-47 Affinity Diagram for Medium NCO Club (no scale)

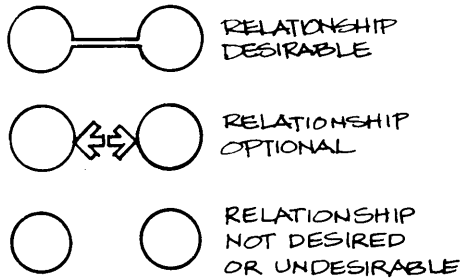
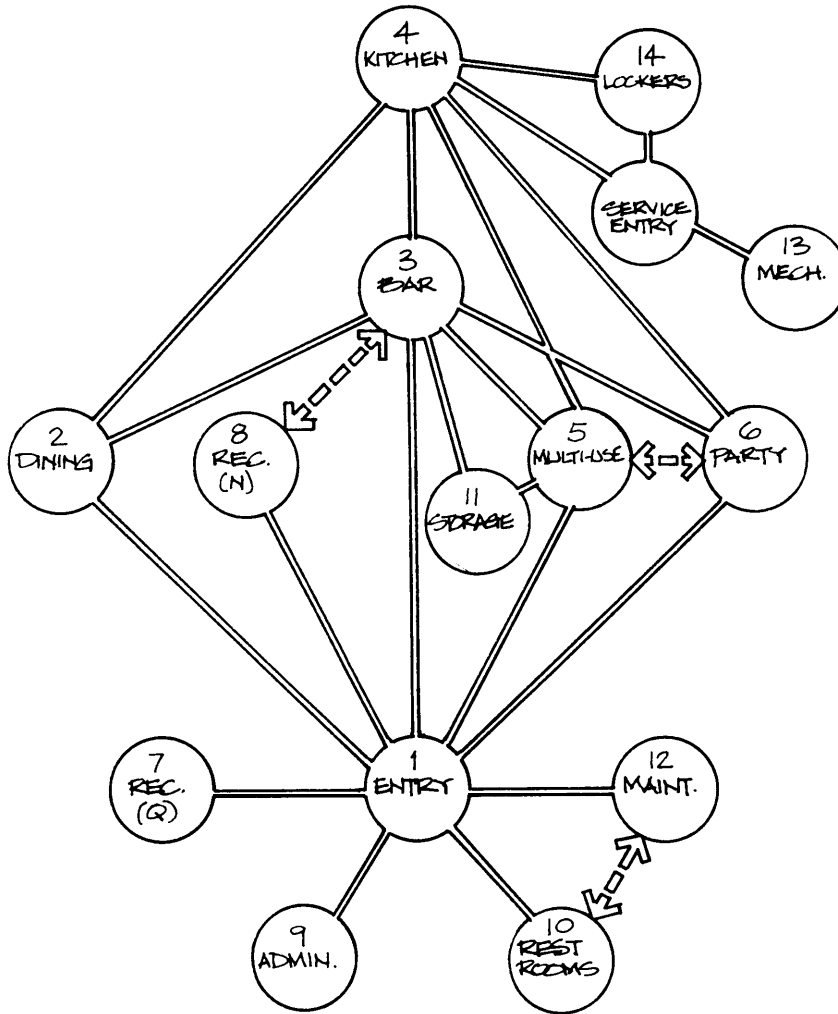

not to scale

MEDIUM NCO CLUB

7-7.4 STEP D - AFFINITY PROGRAM (TO SCALE)

Figure 7-48 Affinity Diagram for Medium NCO Club (to scale)

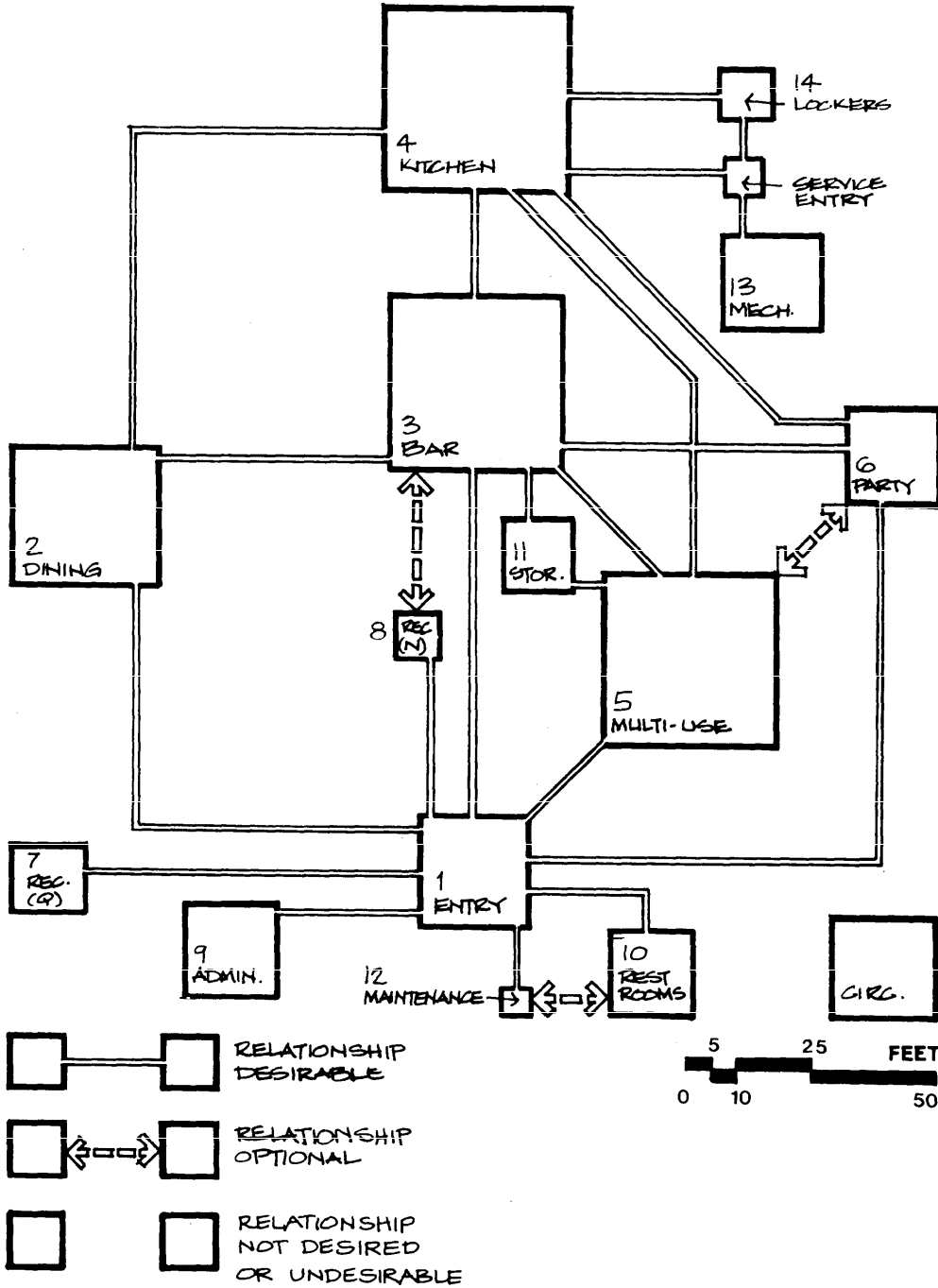

7-7.5 STEP E - PLANNING DIAGRAM

Figure 7-49 Planning Diagram for Medium NCO Club

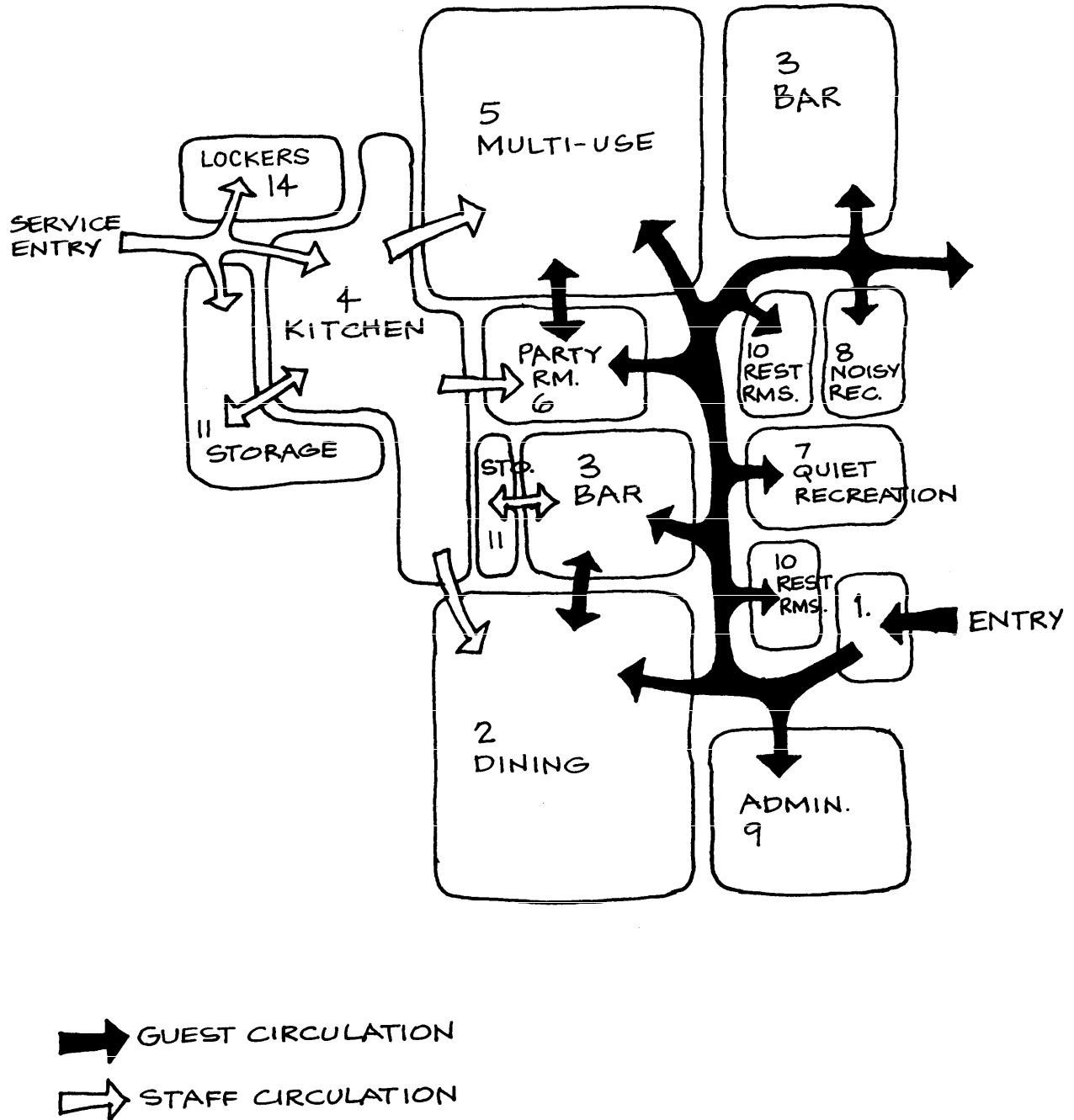

MEDIUM NCO CLUB

7-7.6 STEP F - STRUCTURAL FRAMING

7-7.6.1 Structure: Bearing and shear wall, or two-way rigid frame. Bearing and shear wall will usually be most economical, particularly in seismic areas. Rigid frame will provide for more flexibility in planning for expansion or change.

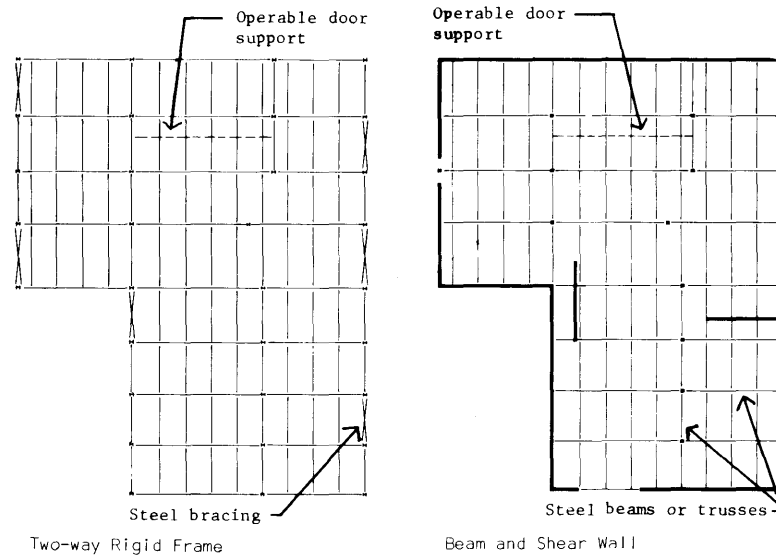

STEP G - SUBSYSTEM CHOICES

7-7.7 H.V.A.C.: System appropriate to climate.

7-7.7.2 Envelope: Masonry or concrete for load bearing and shear wall structure. Non-load bearing masonry or insulated panel infill for rigid frame structure.

7-7.7.3 Interior partitions: Non-load bearing replaceable partitions.

7-7.7.4 Ceiling: Systems appropriate to design requirements.

7-7.7.5 Lighting: Systems appropriate to design requirements.

7-7.8 STEP H - FLOOR PLAN

Figure 7-50 Floor Plan for Medium NCO Club

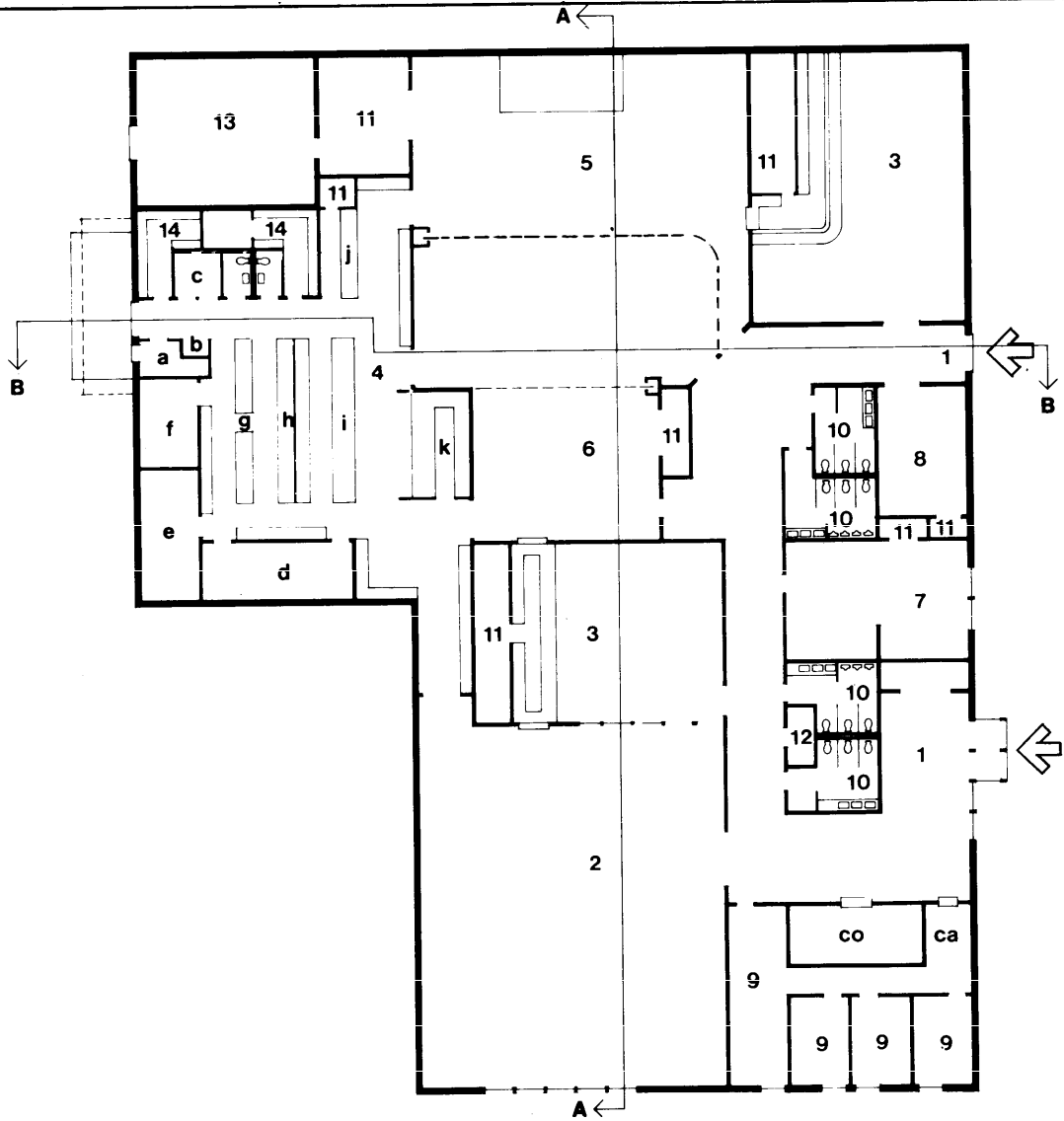

KEY

- | | |
|------------------------|----------------------|
| 1 entry | 5 ballroom/multi-use |
| co coatroom | 6 party room |
| 2 dining | 7 quiet recreation |
| 3 bar | 8 noisy recreation |
| 4 kitchen | 9 administration |
| a waste holding | ca cashier |
| b check-in | 10 restrooms |
| c chef's office | 11 storage |
| d dry storage | 12 maintenance |
| e refrigerated storage | 13 mechanical |
| f freezer storage | 14 locker room |
| g preparation area | |
| h cooking area | |
| i serving area | |
| j banquet make-up | |
| k dishwashing | |

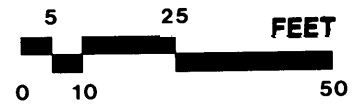

MEDIUM NCO CLUB

7-7.9 STEP 1 - SECTIONS

Figure 7-51 Sections for Medium NCO Club

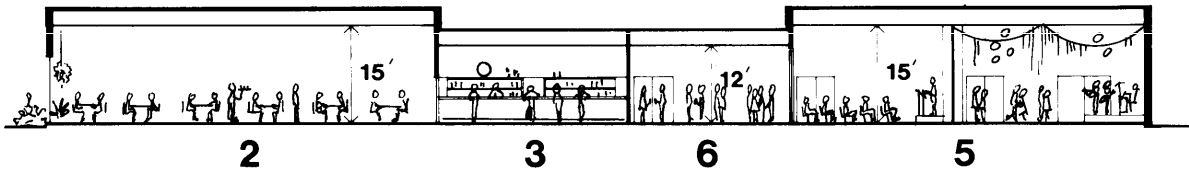

Section A - A

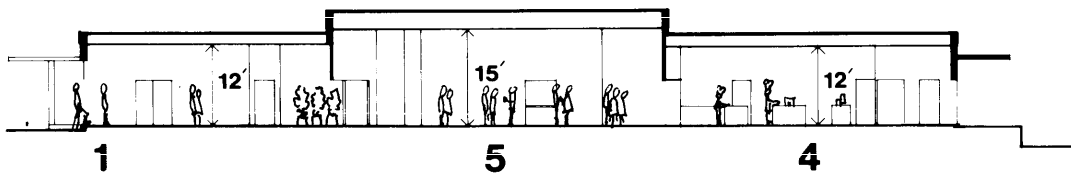

Section B - B

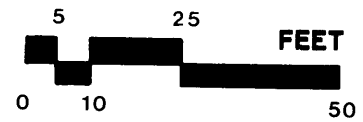

7-7.10 STEP J - SITE PLAN

Figure 7-52 Site Plan for Medium NCO Club

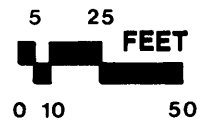
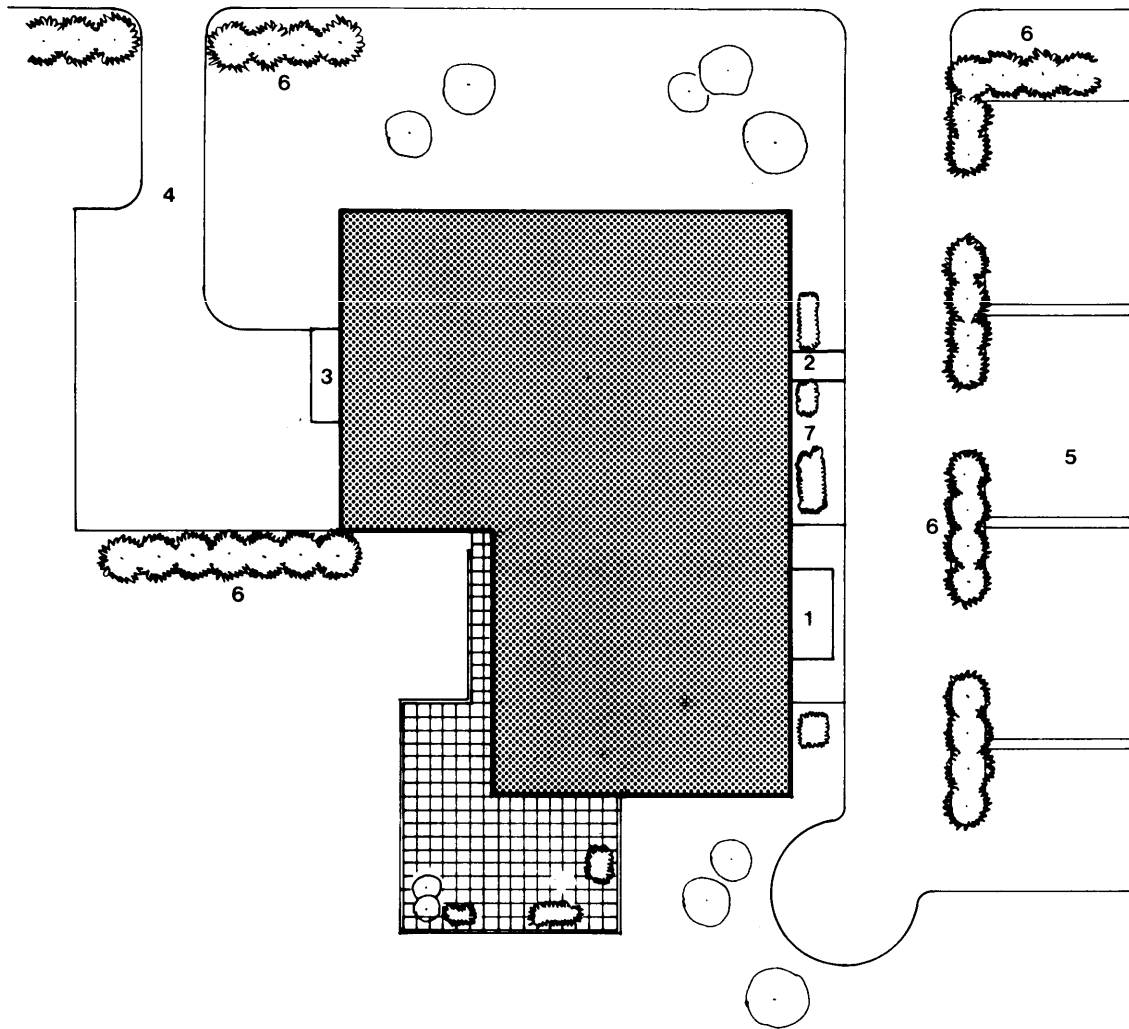

MEDIUM NCO CLUB

7-7.11 STEP K - DESIGN ANALYSIS

7-7.11.1 Plan type: In-line plan.

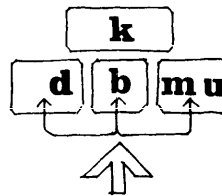

7-7.11.2 Design assumptions: Views unimportant.

7-7.11.3 Planning objectives: Building.

- A. Provision for flexibility between dining room/ballroom unimportant.
- B. Provision for dining room and kitchen expansion important.
- C. Provide separate informal bar located close to game room, with separate entry.

7-7.11.4 Planning evaluation: Building.

- A. Good expansion for kitchen, dining room and ballroom.
- B. Party room well located for service and public entry, and as reception area for ballroom.
- C. Good location for game room opposite informal bar.

7-7.12 STEP L - PLANNING ALTERNATIVES

Objectives: Relocate quiet recreation room to avoid possible acoustic interference from adjoining restrooms and noisy recreation room. In addition, provide storage space with direct access to multi-use room.

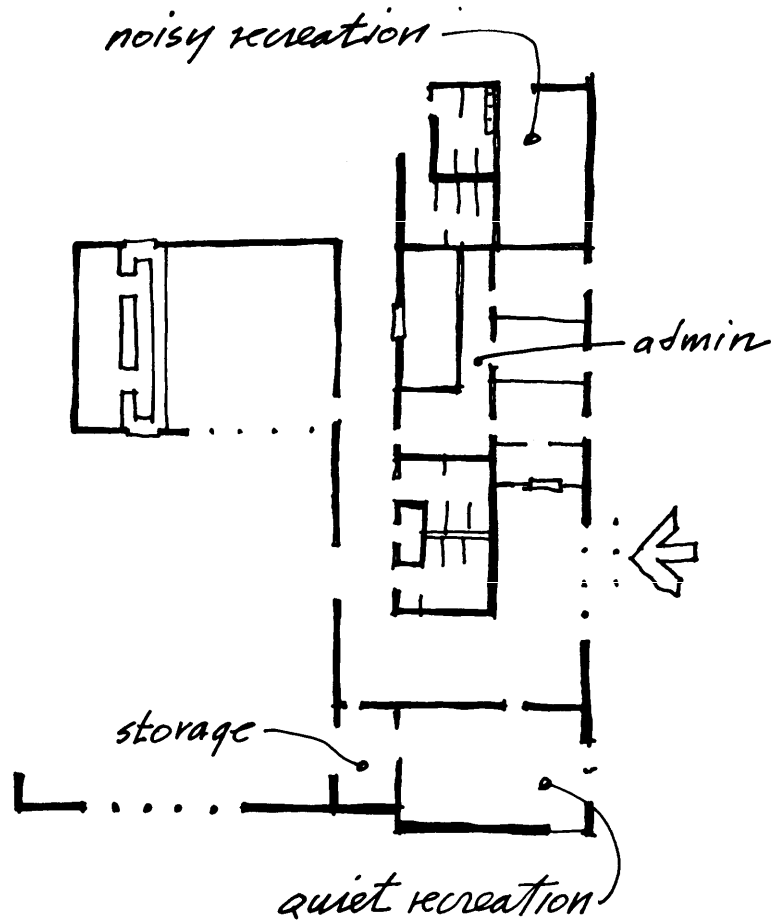

MEDIUM NCO CLUB

7-7.13 STEP M - UTILITY & THERMAL LOADS

7-7.13.1 Building data

A. Gross floor area	17,609 s.f.
B. Max. population at one time	486
C. Max. meals served/day	635

7-7.13.2 Utility loads

A. Electrical: Light and power	690 kva
B. Water: Max. flow rate, cold water	60 gpm
Max. flow rate, hot water	60 gpm
Total flow per day	6,350 gal.
C. Sewage: Total gallons per day	6,350 gal.

7-7.13.3 Heating and cooling loads

A. Heating: Load	698 MBTU/hr.
B. Air conditioning: Tons of refrigeration	61 tons

7-7.13.4 Design assumptions

All policy and design criteria per DOD 4270.1-M.

- A. Estimates are for plans shown.
- B. 40° North latitude
- C. Heat load in kitchen not included in heat gain calculations.
- D. Mechanical room ventilated only.
- E. Single glazing, standard glass.
- F. 20% outside air assumed for ventilation.
- G. Assumed perimeter heat loss: 40 BTU/hr./ft.
- H. Sewage demand based on 10 gpd per person, max. occupancy.
- I. Lighting load assumed 2.5 watts/s.f.

7-8.1 STEP A - SPACE PROGRAM: The space program shown in Figure is based on an assumption of greater demand for dining facilities relative to ballroom area, than the other two NCOs' club examples. A required dining seating capability of 275 is assumed. The military strength served is 2000-3000 NCOs.

Figure 7-53 Space Program for Large NCO Club

Generic Space	Program Area	% Gross Area
1 - Entry	519.5	2.0
2 - Dining Room	3,839.5	14.8
3 - Bar	3,211	12.3
4 - Kitchen	5,335	20.5
5 - Multi-use	3,520	13.5
6 - Party Rooms	737.5	2.9
7 - Rec. Room (Q)	710.5	2.7
8 - Rec. Room (N)	1,150	4.5
9 - Administration	1,310	5
10 - Rest Rooms	852	3.3
11 - Storage	773.5	2.9
12 - Maintenance	38	.1
13 - Mechanical	1,075	4.1
14 - Lockers	374	1.4
Net Usable	23,445.5	90
Gross Area	26,051	100
Dining Room Occupancy:	272 @ 14 sq. ft./seat	
Ballroom Occupancy:	238 - bingo	
	275 - banquet	
Net usable: gross area ratio:	0.90	

For basis upon which the space program is developed, see Sections 2 and 3.

LARGE NCO CLUB

7-8.2 STEP B - AFFINITY MATRIX: The affinity matrix shown in Figure 7-54 indicates relationships between the generic spaces as being desirable (+), of no consequence (0), or undesirable (-). This is based upon use patterns, acoustic compatibility, mutual support for functional operation, sanitary or other reasons. The matrix is intended to denote the desirability of adjacency or separation per se, and along with the space program, is part of the problem statement generated by the using service.

Figure 7-54 Affinity Matrix for Large NCO Club

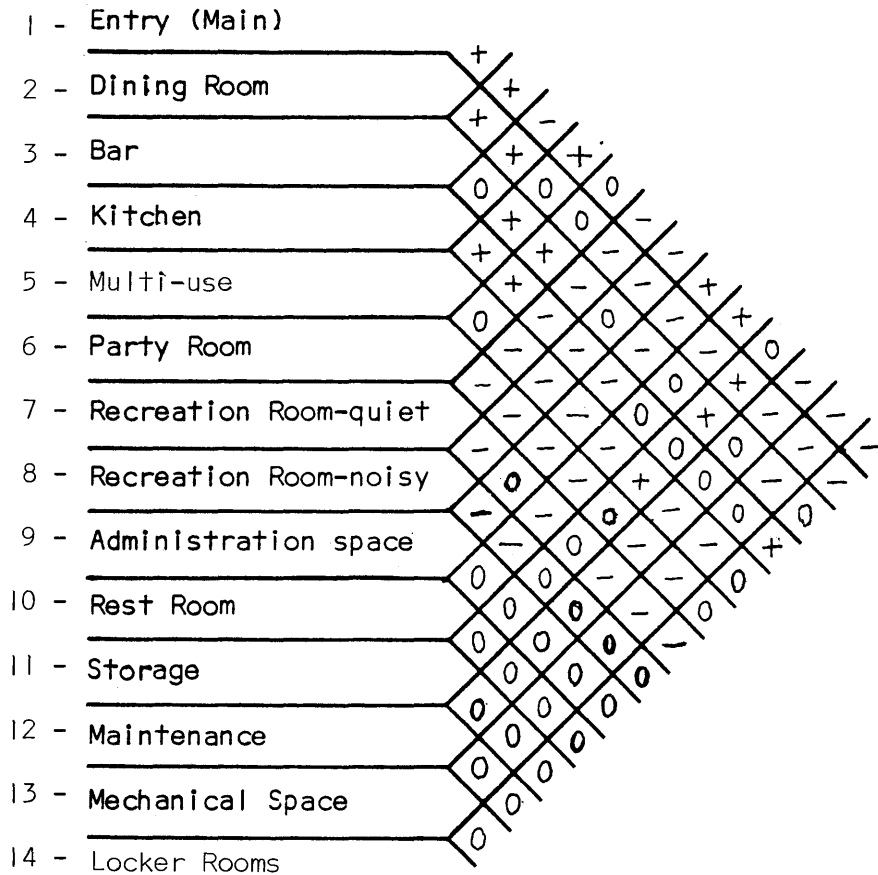

7-8.3 STEP C - AFFINITY DIAGRAM (NO SCALE)

Figure 7-55 Affinity Diagram for Large NCO Club

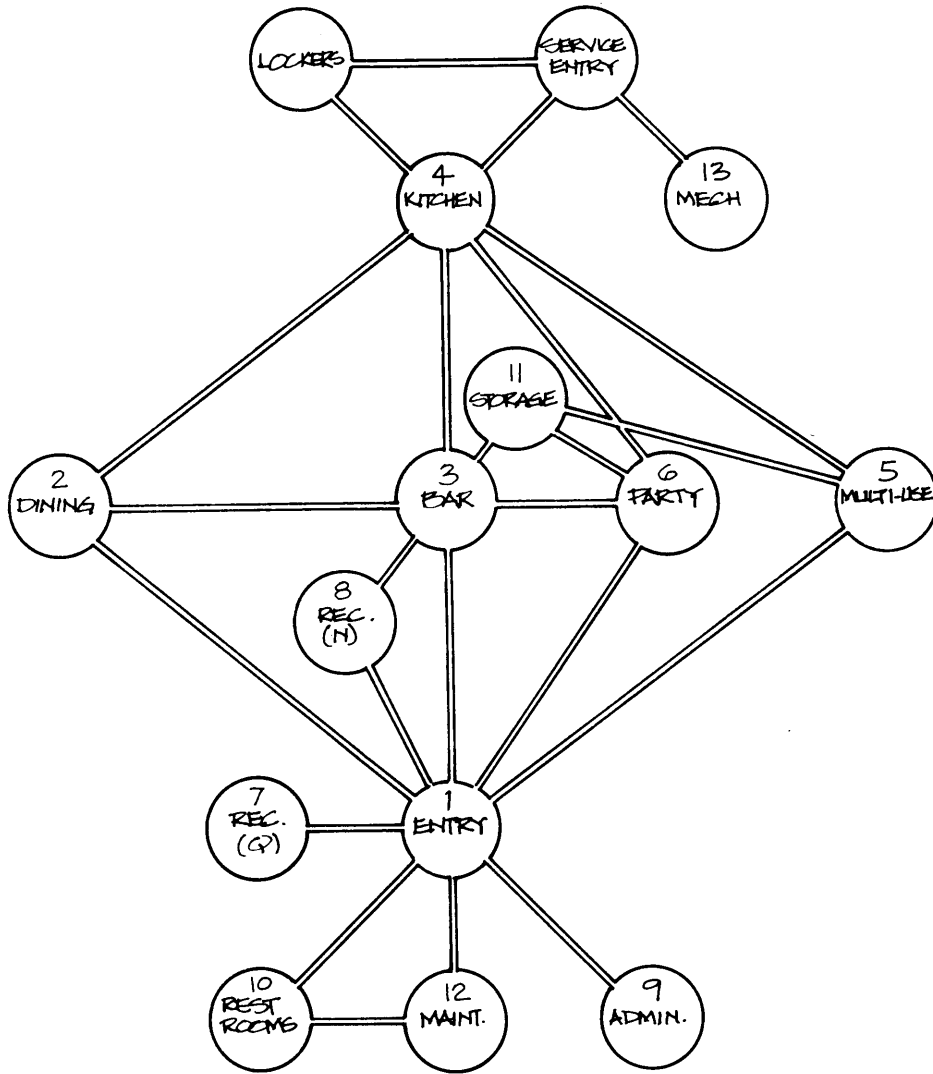

not to scale

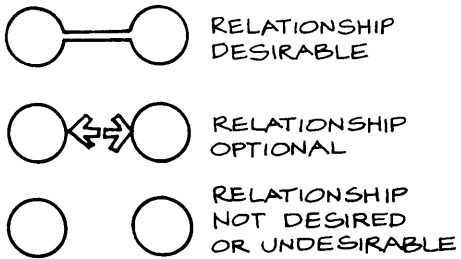

LARGE NCO CLUB

7-8.4 STEP D - AFFINITY DIAGRAM (TO SCALE)

Figure 7-56 Affinity Program for Large NCO Club

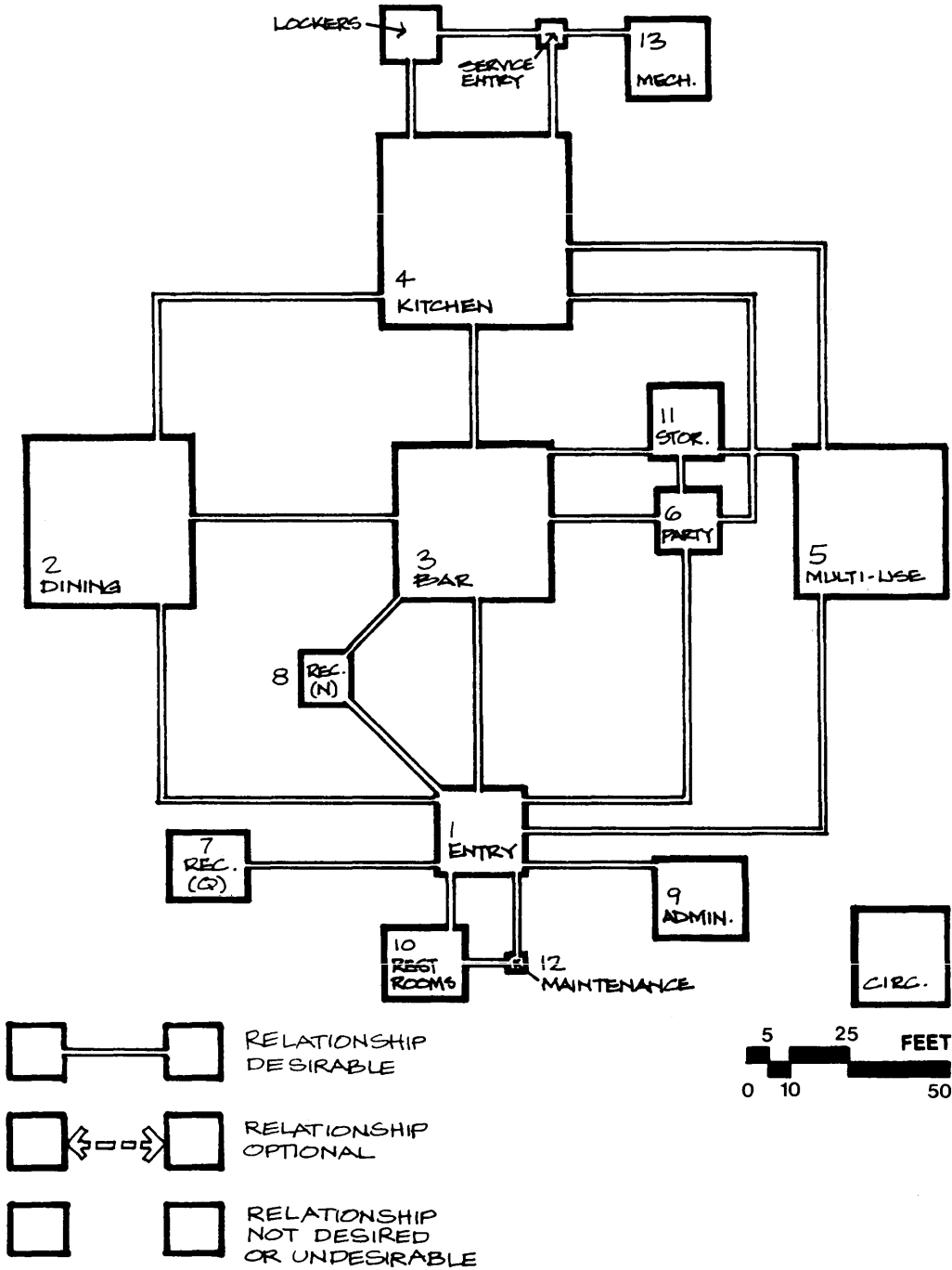

7-8.5 STEP E - PLANNING DIAGRAM

Figure 7-57 Planning Diagram for Large NCO Club

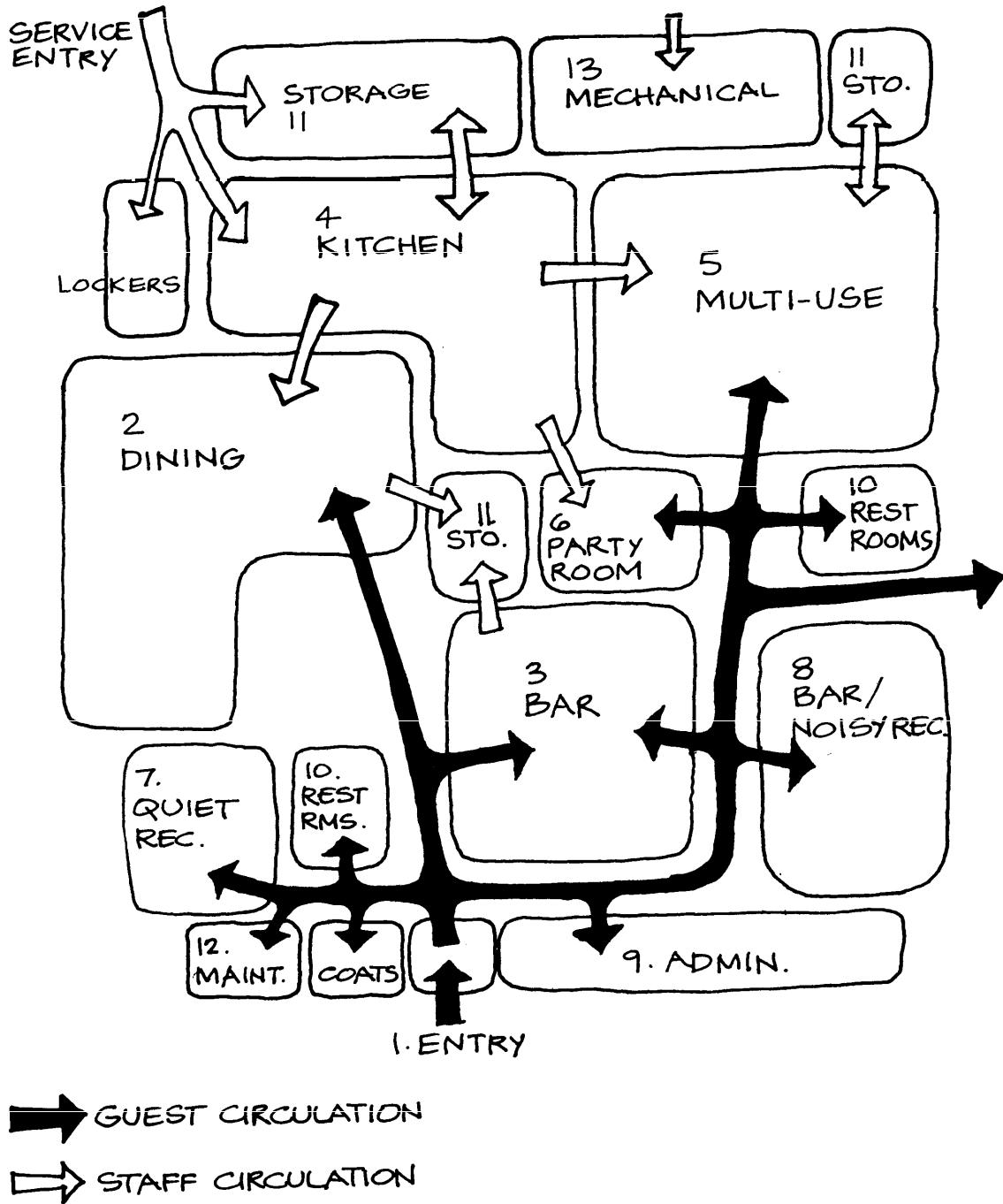

LARGE NCO CLUB

7-8.6 STEP F - STRUCTURAL FRAMING

7-8.6.1 Structure: Alternative 1 shows bearing and shear walls, heavy timber beams and girders, with concrete or masonry columns used as a design element. Alternative 2 uses cantilevered columns with wood beams and girders. This alternative is more flexible than alternative 1, but particularly in seismic areas, will be more expensive. Both alternatives could also economically utilize a steel structure if the design expression of heavy exposed structure is not desired.

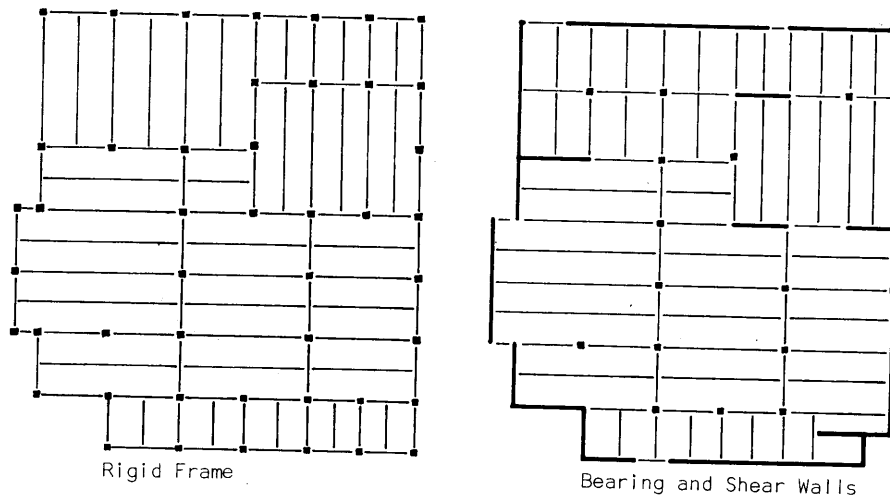

7-8.7 STEP G - SUBSYSTEM CHOICES

7-8.7.1 H.V.A.C.: System appropriate to climate. Note effect of skylights on the heating and cooling loads (STEP M).

7-8.7.2 Envelope: Masonry or concrete.

7-8.7.3 Interior partitions: Non-load bearing replaceable partitions throughout, except for operable wall in multi-use room.

7-8.7.4 Ceiling: Direct application to structure in large public and service areas. Suspended plaster or gypsum board in administration areas.

7-8.7.5 Lighting: Systems appropriate to design requirements.

7-8.8 STEP H - FLOOR PLAN

Figure 7-58 Floor Plan for Large NCO Club

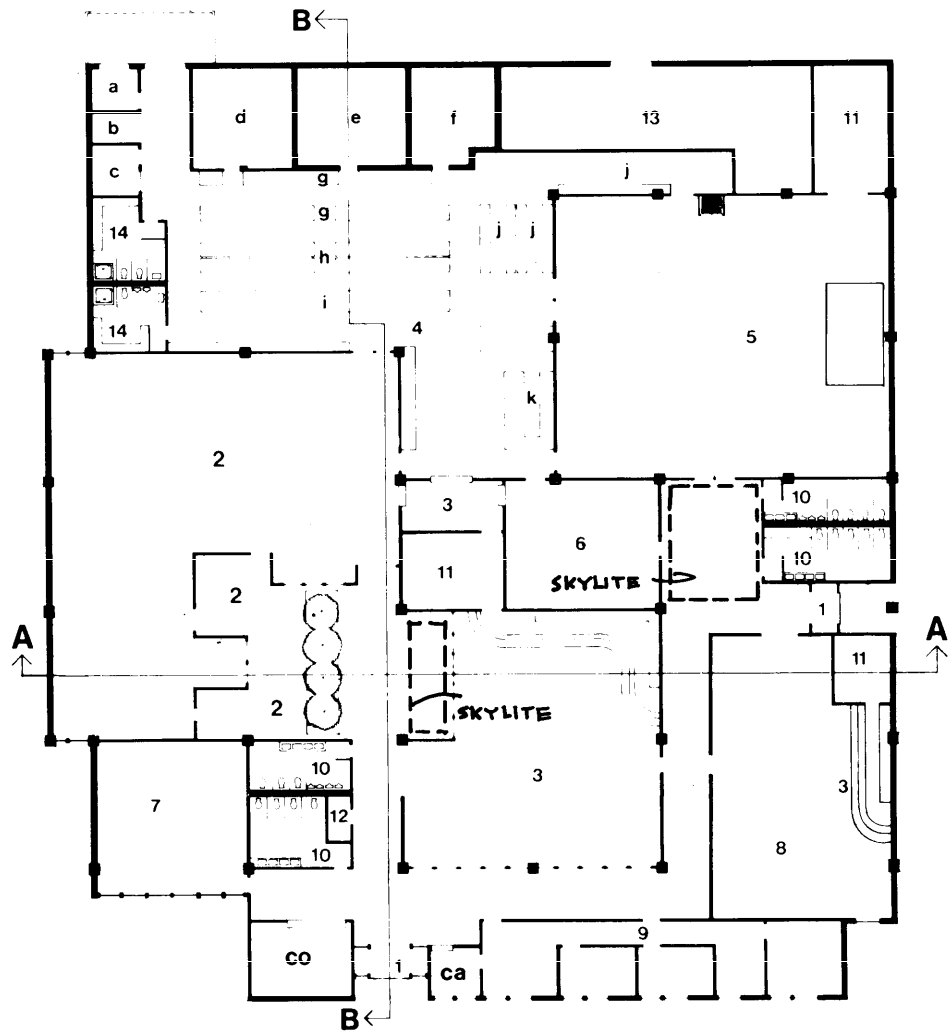

KEY

- | | |
|------------------------|----------------------|
| 1 entry | 5 ballroom/multi-use |
| co coatroom | 6 party room |
| 2 dining | 7 quiet recreation |
| 3 bar | 8 noisy recreation |
| 4 kitchen | 9 administration |
| a waste holding | ca cashier |
| b check-in | 10 restrooms |
| c chef's office | 11 storage |
| d dry storage | 12 maintenance |
| e refrigerated storage | 13 mechanical |
| f freezer storage | 14 locker room |
| g preparation area | |
| h cooking area | |
| i serving area | |
| j banquet make-up | |
| k dishwashing | |

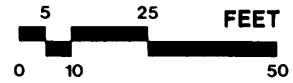

LARGE NCO CLUB

7-8.9 STEP I - SECTIONS

Figure 7-59 Sections for Large NCO Club

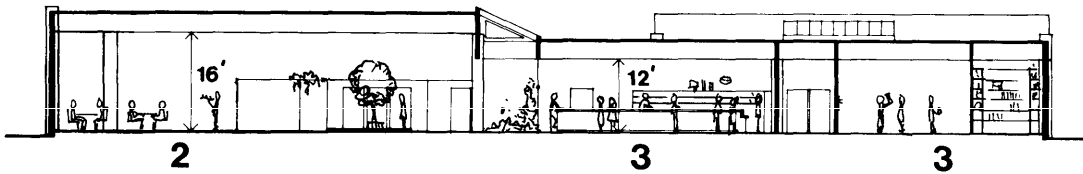

Section A - A

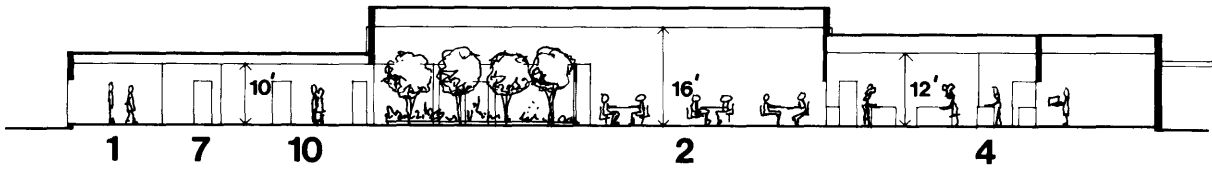

Section B - B

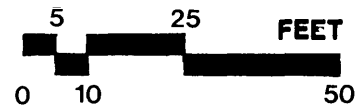

7-8.10 STEP J - SITE PLAN

Figure 7-60 Site Plan for Large NCO Club

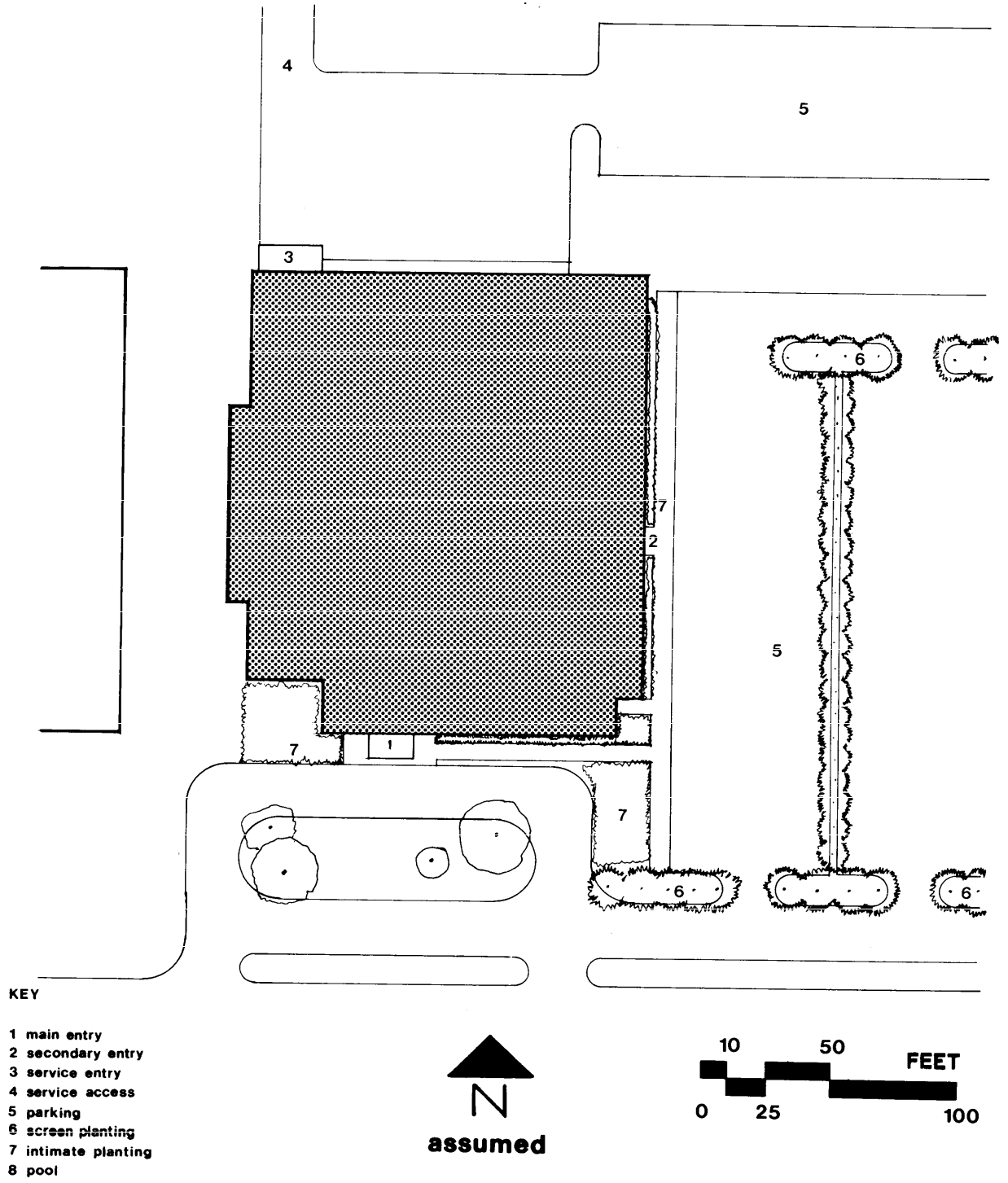

LARGE NCO CLUB

7-8.11 STEP K - DESIGN ANALYSIS

7-8.11.1 Plan type: Three-way plan.

7-8.11.2 Design assumptions

- A. Unattractive surroundings.
- B. Adequate space for one-story solution.
- C. Expansion unimportant; club assumed to be at maximum capacity.
- D. Dining room/multi-use room flexibility unimportant.

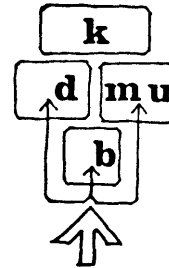

7-8.11.3 Planning objectives:

Building.

- A. Provide solution in which east and west elevations can be blank.
- B. Subdivide dining room in functional and interesting way.
- C. Provide informal bar with separate entrance.
- D. Subdivide main circulation.

7-8.11.4 Planning evaluation:

Building.

- A. Subdivided circulation good.
- B. Circulation area at entry to multi-use room is possible source of congestion and will be unattractive unless well-developed in detail. Skylight helps, at expense of increased construction cost and air conditioning load.
- C. Subdivided dining room provides well for a variety of dining group sizes.

7-8.12 STEP L - PLANNING ALTERNATIVES

7-8.12.1 Many variations are possible for this large club. The large officers clubs A and B illustrate different planning solutions that would also be appropriate for this club.

LARGE NCO CLUB

7-8.13 STEP M - UTILITY & THERMAL LOADS

7-8.13.1 Building data

A. Gross floor area	26,051 s.f.
B. Max. population at one time	765
C. Max. meals served/day	1,100

7-8.13.2 Utility loads

A. Electrical: Light and power	780 kva
B. Water: Max. flow rate, cold water	75 gpm
Max. flow rate, hot water	75 gpm
Total flow per day	11,000 gal.
C. Sewage: Total gallons per day	11,000 gal.

7-8.13.3 Heating and cooling loads

A. Heating: Load	790 *MBTU/hr.
B. Air conditioning: Tons of refrigeration	108 **tons

7-8.13.4 Design assumptions

All policy and design criteria per DOD 4270.1-M.

- A. Estimates are for plans shown.
- B. 40° North latitude.
- C. Heat load in kitchen not included in heat gain calculations.
- D. Mechanical room ventilated only.
- E. Single glazing, standard glass.
- F. 20% outside air assumed for ventilation.
- G. Assumed perimeter heat loss: 40 BTU/hr./ft.
- H. Sewage demand based on 10 gpd per person, max. occupancy.
- I. Lighting load assumed 2.5 watts/s.f.

* Loss due to skylight 37900 BTU/hr.

** Load due to skylight 7.2 tons